

**TOPOLOGY SENSITIVE ALGORITHMS FOR LARGE SCALE UNCAPACITATED
COVERING PROBLEM**

Tarikul Alam Khan Sabbir
Bachelor of Science, Islamic University of Technology, 2006

A Thesis
Submitted to the School of Graduate Studies
of the University of Lethbridge
in Partial Fulfillment of the
Requirements for the Degree

MASTER OF SCIENCE

Department of Mathematics and Computer Science
University of Lethbridge
LETHBRIDGE, ALBERTA, CANADA

© Tarikul Alam Khan Sabbir, 2011

TOPOLOGY SENSITIVE ALGORITHMS FOR LARGE SCALE UNCAPACITATED
COVERING PROBLEM

TARIKUL ALAM KHAN SABBIR

Approved:

Signature

Date

Supervisor:

Co-Supervisor:

Committee Member:

External Examiner:

Chair, Thesis Examination Committee:

I dedicate this thesis to my **parents**.

Abstract

Solving NP-hard facility location problems in wireless network planning is a common scenario. In our research, we study the Covering problem, a well known facility location problem with applications in wireless network deployment. We focus on networks with a sparse structure. First, we analyzed two heuristics of building Tree Decomposition based on vertex separator and perfect elimination order. We extended the vertex separator heuristic to improve its time performance. Second, we propose a dynamic programming algorithm based on the Tree Decomposition to solve the Covering problem optimally on the network. We developed several heuristic techniques to speed up the algorithm. Experiment results show that one variant of the dynamic programming algorithm surpasses the performance of the state of the art mathematical optimization commercial software on several occasions.

Acknowledgments

At first, I would like to thank the Almighty for giving me the strength to finish my thesis. I am forever grateful to my loving family. The continuous word of encouragement from my parents, my brother and my sister-in-law always boosted my confidence and guided me through difficult times.

I would like to take this opportunity to thank all my friends and well-wishers near and abroad who had faith in me even when I did not have faith in myself. I feel lucky to have befriended Chad, Chris, Mecole and Ben, whom I met in Lethbridge. They always made me feel at home in a totally foreign environment. I would also like to thank my fellow grad students Salimur Choudhury, Mohammad Tauhidul Islam, Sangita Bhattacharjee, Kaisar Imam, Shah Mostafa Khaled, Mahmudul Hasan for their continuous support.

I would like to express my deep gratitude for both of my Supervisors. I specially thank Dr. Daya Gaur to give me the opportunity to be his student. His watchful supervision, admirable suggestions and astute guidance throughout the period was essential to complete my thesis. I profoundly thank Dr. Robert Benkoczi for being an outstanding mentor. Without his endless help and continuous reassurance at the most difficult of times, this thesis wouldn't have been a reality. I am indebted to both of them for their unhindered support and the invaluable knowledge they shared with me.

I would like to thank my M.Sc. supervisory committee member Dr. Saurya Das for his constructive suggestions. I would also like to thank my external Dr. Apurva Mudgal for his valuable suggestions and comments. And I must thank Dr. Shahadat Hossain for his continuous advice and help.

I also would like to thank the School of Graduate Studies and the department of Math and Computer Science. Thank you all for supporting me throughout the years and adding to my strength as I continue on the road ahead.

Contents

Approval/Signature Page	ii
Dedication	iii
Abstract	iv
Acknowledgments	v
Table of Contents	vi
List of Tables	viii
List of Figures	ix
1 Introduction	1
1.1 Facility Location Covering Problem	2
1.2 Motivation for Using Tree Decomposition	3
1.3 Summary of Contributions	6
1.4 Thesis Outline	7
2 Background on Tree Decomposition	9
2.1 Definitions and Notations	9
2.1.1 Nice Tree Decomposition	10
2.2 Construction of a Tree Decomposition	11
2.3 Minimum Separating Vertex Set Heuristic	12
2.3.1 Minimum Separating Vertex sets and their Computation	12
2.3.2 MSVS Heuristic	14
2.3.3 Random Separator Vertex set Heuristic (RSVS)	17
2.4 Clique Tree Heuristic	18
2.4.1 Chordal Graph: Definitions and Characteristics	18
2.4.2 Minimum Degree Heuristic	20
2.4.3 Clique Tree Algorithm	21
3 Dynamic Programming Algorithm to Solve Covering Problem	26
3.1 Dynamic Programming Approach	26
3.1.1 Cost function and other Definitions	27
3.1.2 Leaf Node	28
3.1.3 Introduce node	29
3.1.4 Forget Node	30
3.1.5 Join Node	31
3.1.6 Running Time	32
3.1.7 Proof of Correctness	33
3.2 Heuristic Techniques	35
3.2.1 Pruning Heuristic	35

3.2.2	Reductions of cost functions based on the Covering Neighborhood	36
3.2.3	Pruning Using Branch and Bound	39
3.3	Hybrid and Parallel Algorithm	43
3.3.1	A Hybrid algorithm with CPLEX and Dynamic Programming	43
3.3.2	A Parallel Algorithm for Solving Covering Problem	46
3.4	Implementation	48
3.4.1	Dynamic Program	48
3.4.2	Pruning Heuristic Module	50
3.4.3	Branch and Bound Technique	51
3.4.4	Hybrid Algorithm	51
3.4.5	Parallel Algorithm	52
3.4.6	Cost Table Reduction Technique	54
3.4.7	Bounding the Assignment Function	55
3.4.8	Balancing the Height of the Tree Decomposition	58
3.4.9	Using a Modified Dijkstra's algorithm to Compute Shortest Path	60
4	Experiments	61
4.1	Tree Decomposition Experiments	61
4.1.1	Data Sets	62
4.1.2	Tree Decomposition Experiment Results	63
4.2	Covering Problem Algorithm Experiments	65
4.2.1	Data Sets	66
4.2.2	Experiment Results	67
4.3	Analysis	81
5	Conclusion	85
	Bibliography	88

List of Tables

4.1	Tree Decomposition Experiments on Random Dense Graphs	64
4.2	Tree Decomposition Experiments on Random Sparse Graphs	64
4.3	Runtime Comparison among CPLEX, Hybrid Program and Hybrid with BB(Branch and Bound) for a Covering problem Instance where radius = 10, facility opening cost = 15 and penalty = 20	68
4.4	Permutations comparison between Hybrid Program and Hybrid with BB(Branch and Bound) for a Covering problem Instance where radius = 10, facility opening cost = 15 and penalty = 20	70
4.5	Runtime Comparison among CPLEX, Hybrid Program and Hybrid with BB(Branch and Bound) for a Covering problem Instance where radius = 20, facility opening cost = 25 and penalty = 20	72
4.6	Number of Permutations comparison between Hybrid Program and Hybrid with BB(Branch and Bound) for a Covering problem Instance where radius = 20, facility opening cost = 25 and penalty = 20	73
4.7	Runtime Comparison among CPLEX, Hybrid Program and Hybrid with BB(Branch and Bound) for a Covering problem Instance where radius = 30, facility opening cost = 13 and penalty = 22	75
4.8	Number of Permutations comparison between Hybrid Program and Hybrid with BB(Branch and Bound) for a Covering problem Instance where radius = 30, facility opening cost = 13 and penalty = 22	76
4.9	Runtime Comparison among CPLEX, Hybrid Program and Hybrid with BB(Branch and Bound) for a Covering problem Instance where radius = 40, facility opening cost = 10 and penalty = 17	78
4.10	Number of Permutations comparison between Hybrid Program and Hybrid with BB(Branch and Bound) for a Covering problem Instance where radius = 40, facility opening cost = 10 and penalty = 17	79

List of Figures

1.1	An Example of a Covering Problem in a Wireless sensor network	1
1.2	An Example of a Covering Problem in a Wireless sensor network	5
2.1	A graph and it's tree decomposition	10
2.2	Nice Tree Decomposition	11
2.3	Transformation of a non directed graph to its auxiliary equivalent	13
2.4	Improvement step of a tree decomposition [16]	15
2.5	Construction of Tree Decomposition by MSVS	15
2.6	Step by Step execution of Clique Tree Heuristic	24
3.1	Different types of Nice Tree Decomposition nodes with their facility allocation	29
3.1.1	Leaf Node	29
3.1.2	Introduce Node	29
3.1.3	Forget Node	29
3.1.4	Join Node	29
3.2	Subtree G_{T_i} and $G \setminus G_{T_i}$ at node i	34
3.3	Tree Decomposition with Bounds	41
3.4	Solving a Tree Decomposition with the Hybrid Algorithm	44
3.5	Parent and child with common elements	56
3.6	distances representation between clients and facilities	57
3.7	Balancing the Height of a Tree Decomposition	59
4.1	Runtime Comparison among CPLEX, Hybrid and Hybrid_with_bb for client radius = 10, facility opening cost =15 penalty =20	71
4.2	Permutation Comparison between Hybrid and Hybrid_with_bb for client radius = 10, facility opening cost =15 penalty =20	71
4.3	Runtime Comparison among CPLEX, Hybrid and Hybrid_with_bb for client radius = 20, facility opening cost =25 penalty =20	74
4.4	Permutation Comparison between Hybrid and Hybrid_with_bb for client radius = 20, facility opening cost =25 penalty =20	74
4.5	Runtime Comparison among CPLEX, Hybrid and Hybrid_with_bb for client radius = 30, facility opening cost =13 penalty =22	77
4.6	Permutation Comparison between Hybrid and Hybrid_with_bb for client radius = 30, facility opening cost =13 penalty =22	77
4.7	Runtime Comparison among CPLEX, Hybrid and Hybrid_with_bb for client radius = 40, facility opening cost =10 penalty =17	80
4.8	Permutation Comparison between Hybrid and Hybrid_with_bb for client radius = 40, facility opening cost =10 penalty =17	80
4.9	Client Radius Vs Runtime data of the Hybrid program for the graph with 3330 nodes with subproblem size 2000	82
4.10	Client Radius Vs Total number of permutations of Hybrid Program for the graph with 3330 nodes with subproblem size 2000	83

Chapter 1

Introduction

In Wireless Network Planning, many scenarios involves solving NP-hard problems like *Dominating Set*, *Facility Location Covering problem* or *P-median problem*. For example, in wireless sensor networks, often router motes are needed to be placed to collect data from the data collection sensors which is a *Facility location Covering problem*. The objective in this case is to minimize the total number of routers(thus minimizing total cost) while maximizing the sensor Coverage. In Figure 1.1, a superficial instance of a Covering problem in wireless sensor network is shown. In our research we will solve ,the *Facility Location Covering Problem* using a graph theoretical concept called *Tree Decompositions*.

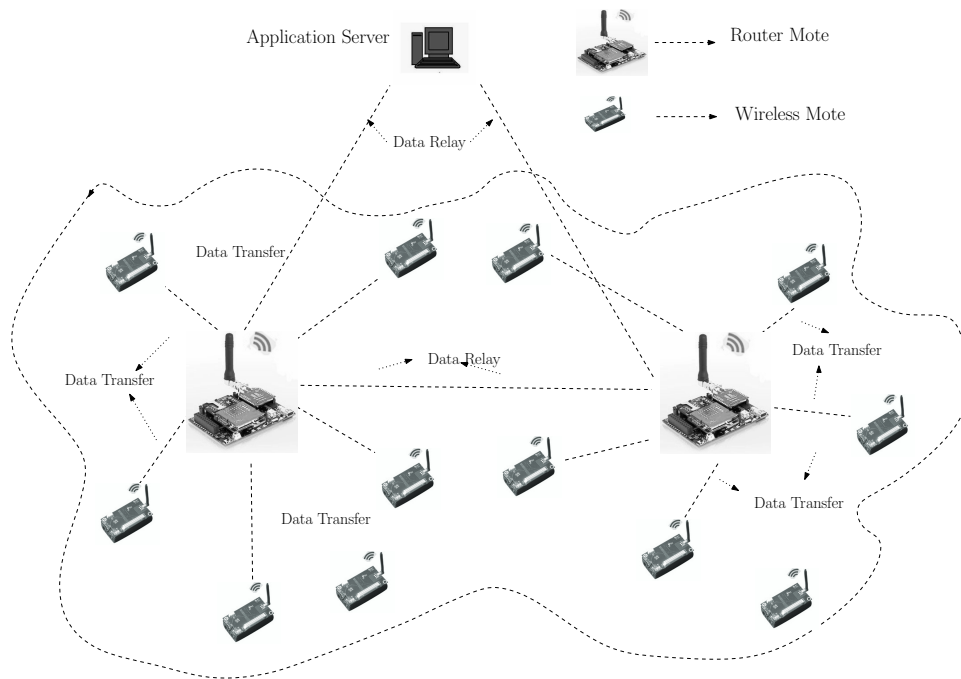

Figure 1.1: An Example of a Covering Problem in a Wireless sensor network

In their study of graph minors, Robertson and Seymour defined the graph structures *path width* [26], *treewidth* [27], and *branchwidth* [25, 28] with their associated graph structures *path decomposition*,

tree decomposition and *branch decomposition*. These notions proved to be useful in many areas of computational complexity theory. Many NP-hard graph problems can be solved in polynomial time for graphs with pathwidth, treewidth or branchwidth bounded by a constant. In this thesis we will employ a dynamic programming algorithm which uses the tree decomposition to solve the *Facility location Covering Problem*.

In section 1.1 we will describe a formal definition of the *Facility Location Covering Problem*. In Section 1.2, we will discuss the motivation behind using tree decomposition for our problem. In section 1.3, we will provide a outline of our thesis.

1.1 Facility Location Covering Problem

Following we will describe the *client constrained Covering problem* as defined by Kolen and Tamir [15].

$$\begin{aligned}
 &\text{Minimise} && \sum_{j=1}^n c_j y_j + \sum_{i=1}^m b_i z_i \\
 &\text{subject to} && \sum_{j=1}^n a_{ij} y_j + z_i \geq 1, i = 1, \dots, m \\
 &&& y_j \in \{0, 1\}, j = 1, \dots, n \\
 &&& z_i \in \{0, 1\}, i = 1, \dots, m
 \end{aligned} \tag{1.1}$$

Where, m and n are finite index sets and a_{ij} is an $|n| \times |m|$ (0,1) matrix. Let, $G = (V, E)$ be an undirected network with node set $v = \{v_1, v_2 \dots v_m\}$ and edge set E . We define $d(v_i, v_j)$ is the shortest path distance between client v_i and v_j . We assume that at each node there exists exactly one client. We refer to the client located at node v_i as client i , $i = 1, 2, \dots, m$. If client i is not served by any facility, then a non-negative penalty cost of b_i is incurred. We assume that the set of potential sites for the facilities is a subset of nodes of the network. Without loss of generality let this be $v' = v_1, v_2, \dots, v_n, n \leq m$. The non negative setup cost of establishing a facility at v_j is $c_j, j = 1, 2, \dots, n$ (we will refer to a facility established at site v_j as facility $j, j = 1, 2, \dots, n$). The client constrained

covering problem corresponds to the case where we have a region of attraction of radius r_i for client i and we set $a_{ij} = 1$ if and only if $d(v_i, v_j) \leq r_i$, $i = 1, 2, \dots, m$, $j = 1, 2, \dots, n$, which means for every facility opened at vertex i , $i = 1, 2, \dots, m$, every client j , $j = 1, 2, \dots, n$ is either covered or uncovered, in the later case a penalty is incurred.

We define the *LP-relaxation* of (1.1) by replacing the integrality constraints by the non negativity constraints on the variables. The relaxation of (1.1) is given below-

$$\begin{aligned}
 & \text{Minimise} && \sum_{j=1}^n c_j y_j + \sum_{i=1}^m b_i z_i \\
 & \text{subject to} && \sum_{j=1}^n a_{ij} y_j + z_i \geq 1, \quad i = 1, \dots, m \\
 & && 0 \leq y_j \leq 1, \quad j = 1, \dots, n \\
 & && 0 \leq z_i \leq 1, \quad i = 1, \dots, m
 \end{aligned} \tag{1.2}$$

In our research, we will model a CPLEX (a mathematical problem solver tool) instance according to this linear program to solve subproblems of an input graph.

1.2 Motivation for Using Tree Decomposition

In many wireless networks, the graph representation of the flow of data has a decisive connectedness that resembles a tree like pattern. The current methods for solving optimization problems such as integer programming doesn't take this property into account. In our research we wanted to exploit this property. The idea of using tree decomposition is derived from the fact that many NP-hard problems like Maximum-Weight Independent Set, Graph Coloring problem and Dominating Set problem can be solved polynomially when the input is a tree (a restricted structure which has no cycle). We can easily build a dynamic programming algorithm which exploits the fact that on a tree the computation can be broken down into several subproblems with very limited interaction among them (see figure 1.2). Once we decide whether or not to include a node in the dominating set, the subproblems in each subtree becomes completely separated; we can solve each as though the others did not exist [13].

We don't encounter such a nice situation in general graphs (or in graphs derived from the wireless networks), where there might not be a node that "breaks the communication" between subproblems in the rest of the graphs. But in such cases we can recursively decompose the input graph by removing small sets of nodes rather removing a single node to break the communication among subproblems in the graph. This means that these graphs have a "tree like" pattern. By utilizing this tree like structure, it is possible to design a dynamic programming algorithm to solve NP-hard problems on general graphs. Not all wireless sensor networks have a tree like structure. In certain applications, we conjecture that the treewidth of sensor net graphs is small. We will use such graphs (graphs are randomly generated to mimic a network structure) to solve the *Facility Location Covering problem* using a dynamic programming algorithm that exploits the independent subproblem structure of those graphs. But before that we need to decompose a graph into that structure which discerns its tree like characteristics. This structure is called a *tree decomposition*.

To better understand the intuition behind the tree decomposition of a general graph, let us discuss Figure 1.2. The graph G pictured in this figure is decomposable in a tree like way. If G is seen like in the Figure 1.2(a), then its tree like structure might not appear immediately. In Figure 1.2(b), however, we see that G is actually composed of ten interlocking triangles; and seven of the ten triangles have the property that if we delete them, then the remainder of G falls apart into disconnected pieces that recursively have this interlocking-triangle structure. The other three triangles are attached at the extremities, and deleting them is similar to deleting the leaves of a tree.

In Figure 1.2(a), it is apparent that G has many cycles, but in the Figure 1.2(b), it appears as though it does not have any cycles when it is viewed as ten interlocking triangles. Based on this structure, G inherits many of the nice decomposition properties of a tree.

In Figure 1.2(c) a tree representation of the graph is shown where each node corresponds to one of the triangles of the graph in Figure 1.2(b). Two tree nodes are adjacent if the correspondent trian-

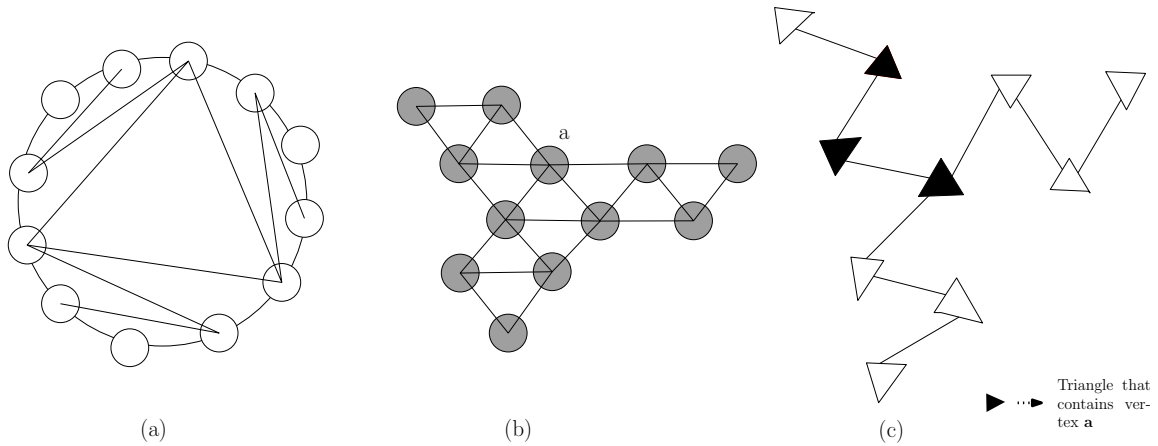

Parts(a) and (b) depict the same graph drawn in different ways.Part(b) emphasizes the way in which it is composed of ten interlocking triangles. Part(c) illustrates schematically how these ten triangles "fit together". It also shows triangles containing a vertex forming a subtree(black triangles).[Algorithm Design-Kleinberg, Tardos, 2006]

Figure 1.2: An Example of a Covering Problem in a Wireless sensor network

gles have common graph vertices. If we notice in Figure 1.2(c), the nodes in the tree that shares a common vertex forms a connected subtree within the tree. For example, vertex a is shared by 3 triangles in Figure 1.2(b). In the tree, they are represented by black triangles which forms a connected subtree. So, we can say that graph G has been decomposed into a tree like pattern, and the final output is called a *tree decomposition of G* [13]. If we compare between a tree (a graph without a cycle) and tree decomposition the difference that is noticeable is that each node in a tree is a single vertex, whereas in a tree decomposition every node is composed of a set of vertices of the input graph. If we delete a single node in a tree then it separates the tree into more than one connected subtree. Similarly in a tree decomposition, if we delete a node then it separates the entire graph into more than one connected components, which as described earlier is one of the key reason for using tree decomposition. The formal definition of a tree decomposition is discussed in Chapter 2, section 2.1.

Another reason to use *tree decomposition* is the recent computational study results. Though at the beginning, the application of *tree decomposition* has been considered for theoretical interest only, over the years research studies have shown that Tree Decompositions can be applied in practical purposes too. One of the first attempt is taken by Cook and Seymour [7]. They used branch decom-

positions to obtain close-to-optimal solutions of the traveling salesman problem. Path decompositions are used by Verweij [31] to solve lifting problems of cycle inequalities for the independent set problem. Koster, Van Hoesel and Kolen [17, 19] used tree decompositions to obtain lower bounds and optimal solutions for a special type frequency assignment problems. Currently one of the most efficient algorithm for the inference calculation in probabilistic (or Bayesian) networks builds upon a tree decomposition of a network's moralized graph [12, 21]. These studies implies that dynamic programming algorithm based on a path/tree/branch decomposition of the graph can be an alternative for integer programming techniques to solve hard optimization problems.

1.3 Summary of Contributions

The primary goal of our research is to investigate whether the use of algorithms that exploits structure of sensor network graphs using tree decomposition are practical or not. We chose a fundamental facility location problem (the Covering problem) that models sensor net deployment. Solving Covering problem with dynamic programming exists for trees but not for tree decompositions. We conclude that dynamic programming on tree decomposition is expensive in terms of memory requirement because of the fact that swapping occurs frequently between main memory and data storage to compensate the lack of main memory. We propose several heuristics meant to reduce the storage which are discussed in Chapter 3. We also propose an algorithm which uses the tree decomposition partially by stopping the recursive step in dynamic programming before the reaching the leaves of the decomposition. The bottom halve of the tree decomposition is solved by an optimization software package called CPLEX.

The secondary goal of our research is to review the practicality of computing tree decomposition. Two types of heuristics are used in practices. The first type is based on finding *minimum separator* of a graph. The second type is based on a chordal graph characteristic called *perfect elimination order* which is then used to find a clique tree from a graph. We implemented two heuristics based on these two types. Another heuristic is developed based on the minimum separator heuristic which

randomly selects a separator instead of a minimum separator. After experiments (details in Chapter 4), we conclude that clique tree heuristic is the fastest producing good quality tree decomposition while minimum separator heuristic produces better quality tree decomposition but really expensive in terms of running time. The random separator heuristic performs well in terms of running time with good quality tree decomposition compared to the minimum separator heuristic. As we discuss in the Conclusion chapter, one of the ideas that is conceived from our research is to use a partial tree decomposition rather than using an entire one. In this respect, the separator based heuristic should be useful as the algorithms for the partial tree decomposition should decide on finding a balanced separator as a root so that the components of the graph left without a tree decomposition will be balanced in size.

1.4 Thesis Outline

Solving an optimization problem using *tree decomposition* of a graph of bounded treewidth is a two step procedure:(i) computation of a (good) tree decomposition, and (ii) application of an algorithm (dynamic programming) based on the tree decomposition. We divided the chapters of this thesis in this respect.

In Chapter 2, we discuss about the formal definition of tree decomposition and the two heuristics to compute a good (may be not optimal) tree decomposition of the input graph. Also *nice tree decomposition*, another form of tree decomposition is discussed.

In Chapter 3, we discuss about the dynamic programming algorithm that solves the Covering problem on the tree decomposition (computed by the heuristics in Chapter 2) of a graph. We discuss several techniques which helped us to prune the redundant cost functions in order to make the algorithm more efficient. We also discuss a variant of this algorithm in which a part of the tree decomposition is solved by CPLEX, an optimization software package, rather than the dynamic program.

In Chapter 4, we discuss the empirical results and analysis of our algorithms. Several data tables and graph comparisons are made to facilitate the scrutiny. In Chapter 5, we discuss the implications of our research with future directions.

Chapter 2

Background on Tree Decomposition

In this chapter we will discuss the concept and definition of Tree Decomposition and its computation. In section 2.1 we discuss the formal definition of Tree Decomposition and Nice Tree Decomposition. As computing Tree Decomposition of a graph is NP-hard, we use heuristics with good practical running time to compute the Tree Decomposition. In section 2.3 and section 2.4 we described in detail the two heuristics, minimum separator heuristics and clique tree heuristics with pseudo-code algorithm.

2.1 Definitions and Notations

We introduce the definitions and notations that will be used throughout this thesis. Let $G = (V, E)$ be an undirected graph with vertex set V and edge set E . Let $n = |V|$ and $m = |E|$. The set of adjacent vertices denoted by $N(v) = \{w \in V : vw \in E\}$. Let $\delta(v) = |N(v)|$ be the degree of v . A set of vertices $Q \subseteq V$ is called a *clique* in G if there is an edge between every pair of distinct vertices from Q . The cardinality $|Q|$ of Q is the size of the clique [18].

Now, Let us formally define the tree decomposition of an input graph G .

Definition (Robertson and Seymour [27]). Let $G = (V, E)$ be a graph. A tree decomposition of G is a pair (T, χ) , where $T = (I, F)$ is a tree with node set I and edge set F , and $\chi = \{X_i : i \in I\}$ is a family of subsets of V , one of each node of T , such that

- (i) $\bigcup_{i \in I} X_i = V$,
- (ii) for every edge $vw \in E$, there is an $i \in I$ with $v \in X_i$ and $w \in X_i$, and
- (iii) for all $i, j, k \in I$, if j is on the path from i to k in T , then $X_i \cap X_k \subseteq X_j$.

The **width** of a tree decomposition is $\max_{i \in I} |X_i| - 1$. The **treewidth** of a graph G , denoted by $tw(G)$, is the minimum width over all possible tree decompositions of G .

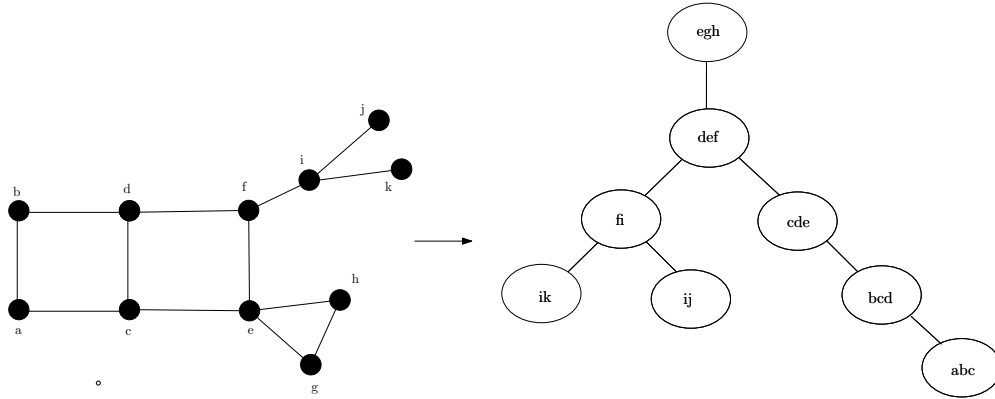

Figure (a) : An example graph

Figure (b) : A tree decomposition of the graph

Figure 2.1: A graph and its tree decomposition

The third condition of the tree decomposition is equivalent to the condition that for all $v \in V$, the set of nodes $\{i \in I : v \in X_i\}$ is a connected subtree of T . Figure 2.1 shows a graph and its tree decomposition [18].

2.1.1 Nice Tree Decomposition

A tree decomposition can be easily converted in a nice tree decomposition of the same width with a linear size of T . The resulting tree is rooted and binary [5]. There are four kinds of nodes in a *nice tree decomposition* -

- **Leaf** nodes i are leaves of T and have $|X_i| = 1$.
- **Introduce** nodes i have one child j with $X_i = X_j \cup \{v\}$ for some vertex $v \in V$.
- **Forget** nodes i have one child j with $X_i = X_j - \{v\}$ for some vertex $v \in V$.
- **Join** nodes i have two children j with $X_i = X_{j_1} = X_{j_2}$.

In our algorithm we used a nice tree decomposition instead of a normal tree decomposition which considerably eases the design of the algorithm which solves the covering problem. Details are described in chapter 3. In figure 2.2 a nice tree decomposition of a normal tree decomposition (of a graph from figure 2.1) is shown.

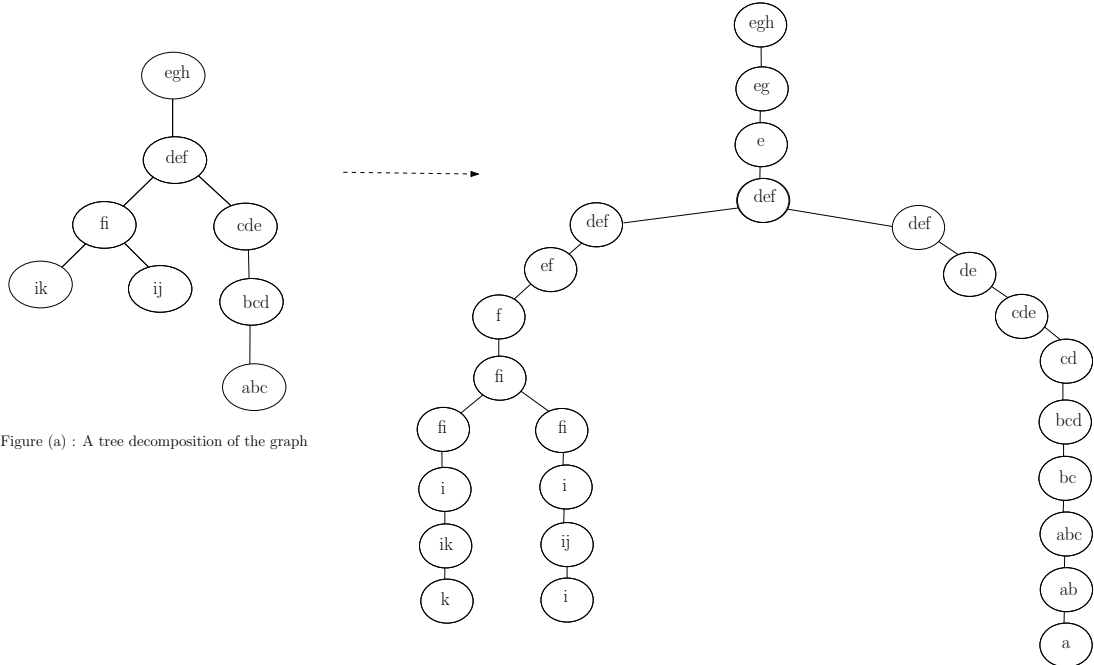

Figure (a) : A tree decomposition of the graph

Figure (b) : Nice tree decomposition of the graph

Figure 2.2: Nice Tree Decomposition

2.2 Construction of a Tree Decomposition

Finding a tree decomposition with optimal width is NP-hard [4]. In our research we used two heuristics without any theoretical quality guarantee to compute tree decomposition of a graph which approximates the treewidth close to optimality with a reasonable running time. The two heuristics are

- (i) *Minimum Separating Vertex Set heuristic (MSVS)*
- (ii) *Clique tree heuristic*

The reason they are called heuristics because, these algorithms don't have a solid theoretical guarantee but in practicality they performs well. Following, we describe these two heuristics in detail.

2.3 Minimum Separating Vertex Set Heuristic

This heuristic was developed in the context of solving frequency assignment problems with a tree decomposition approach [16]. It is based on a characteristics of a tree decomposition. Every tree decomposition can be transformed to a tree decomposition in which the vertex set associated to an internal node separates the graph into at least two components, the vertices associated with the node form a *separating vertex set*. The heuristic therefore searches for separating vertex sets. To find a good tree decomposition, we in fact search for minimum separating vertex sets.

Before we describe the MSVS heuristic, we briefly describe how a separating vertex set of minimum cardinality can be found in a graph.

2.3.1 Minimum Separating Vertex sets and their Computation

Definition (Minimum Separating Vertex set). An st -separating set of a graph $G = (V, E)$ is a set $S \subseteq V \setminus \{s, t\}$ with the property that any path from s to t passes through a vertex of S . The minimum separating vertex set of G is given by the st -separating set S with minimum cardinality over all combinations $st \notin E$.

As described by Ahuja, Magnanti and Orlin [1], the st -separating set with minimum cardinality can be found efficiently using Menger's theorem.

Theorem 1 (Menger [22]). *Given a graph $G = (V, E)$ and two distinct non-adjacent vertices $s, t \in V$, the minimum number of vertices in an st -separating set is equal to the maximum number of vertex-disjoint paths connecting s and t .*

So, we have to calculate the maximum number of vertex-disjoint paths. This problem is solvable in polynomial time by standard network flow techniques. First, G is transformed into a directed graph $D = (V, A)$ in which each edge vw is replaced by two arcs (v, w) and (w, v) . Next, we construct an auxiliary directed graph D' , with weights on the arcs, by

- replacing each vertex v by two vertices v' and v'' ,

- redirecting each arc with head v to v' , and introducing a weight of ∞ ,
- redirecting each arc with tail v to v'' , and introducing a weight of ∞ , and
- adding an arc from v' to v'' with weight 1.

In the following Figure 2.3, such a transformation from a non directed Grid graph G to its auxiliary directed equivalent D' is shown.

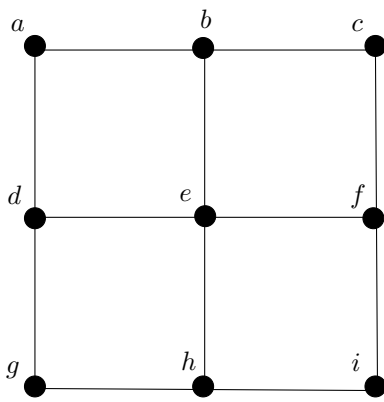

Figure (a): Non Directed Grid graph G

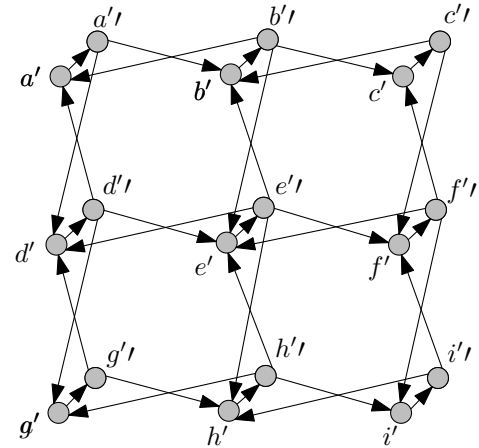

Figure (b): Auxiliary directed Graph D'

Figure 2.3: Transformation of a non directed graph to its auxiliary equivalent

Figure(a) of 2.3 corresponds to a non directed Grid Graph G of nine vertices. Figure(b) of 2,3 corresponds to a auxiliary directed graph D' after its construction from the non directed graph G as instructed above. Here each vertex v in Figure(a) is replaced by two vertices v' and v'' in Figure(b). Incoming edges ended at vertex v' and outgoing edges originated at v'' . Each edge from v' to v'' has weight 1. All the other edges have ∞ as their weight.

The minimum number of vertices in an st -separating set in G is equal to the minimum weight of an $s''-t'$ cut in D' . So, if we calculate the minimum $s''-t'$ cut for every non-adjacent pair $s, t \in V$, we obtain the minimum separating vertex set [16].

In the next section, we describe the MSVS heuristic algorithm that builds a tree decomposition by finding the separator of the input graph.

2.3.2 MSVS Heuristic

The MSVS heuristic is an improvement heuristic. We start with the trivial tree decomposition in which we have one node corresponding to the complete graph. During the process we have a tree decomposition (T, χ) , where I is the node set and F is the edge set of the tree T . We select the node $i \in I$ with $|X_i|$ maximum. This node is replaced by $m + 1$ nodes i_0, \dots, i_m with vertex sets X_{i_0}, \dots, X_{i_m} . The nodes i_1, \dots, i_m are connected with i_0 . Each node $k \in N(i)$ is connected to exactly one node $j \in \{i_0 \dots i_m\}$, such that all conditions of a tree decomposition are satisfied again.

The sets X_{i_0}, \dots, X_{i_m} are defined as follows. We construct a graph $H = (V(H), E(H))$ where $V(H)$ consists of set X_i and $E(H)$ consists of the induced subgraph G_{X_i} and $\bigcup_{k \in N(i)} C(X_i \cap X_k)$, which denotes the additional edges, where $C(X)$ denotes a complete graph on the vertices X . If H is a complete graph, then $X_{i_0} := X_i$ and $m = 0$, i.e. we do not change the tree decomposition. If H is not a clique, then we calculate a minimum separating vertex set $S \subseteq X_i$. These actions corresponds to line 1 and 4 of Algorithm 2.1 described later. Let Y_{i_1}, \dots, Y_{i_m} be the vertex sets of the $m \geq 2$ components of $H_{V(H) \setminus S}$. We define $X_{i_0} := S$, and $X_{i_j} := Y_{i_j} \cup S$ for all $j \in 1, \dots, m$ which corresponds to lines 9-13 of Algorithm 2.1. The set X_k has a non-empty intersection with at most one set Y_{i_j} , $j = 1, \dots, m$: Let $v, w \in X_i \cap X_k$, then $\{v, w\} \in C(X_i \cap X_k) \subset E(H)$, which implies that v and w cannot be separated by S . So, either $v, w \in S$ or $v, w \in Y_{i_j} \cup S$ for only one $j \in \{1, \dots, m\}$. Therefore, we connect each neighbor $k \in N(i)$ with the node i_j , $j \in \{1, \dots, m\}$ for which the intersection of X_k and Y_{i_j} is non-empty, or in case there is none the we connect with i_0 (corresponds to lines 14-18 of Algorithm 2.1). As a consequence, the new construction is a tree again (see Figure 2.3). In Figure 2.4, a step by step construction of the tree decomposition is shown.

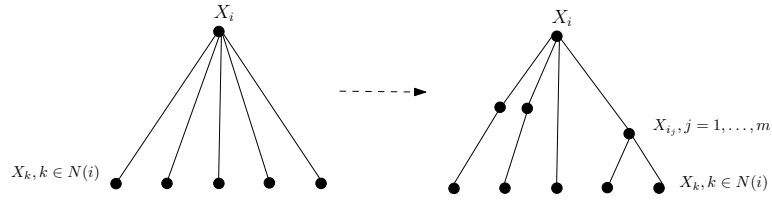

Figure 2.4: Improvement step of a tree decomposition [16]

In the new tree the conditions for a valid tree decomposition again hold. Since $\bigcup_{j=0}^m X_{i_j} = (\bigcup_{j=0}^m Y_{i_j}) \cup S = X_i$, condition (i) (from Section 2.1) is satisfied. To satisfy condition (ii) we have to prove that for each edge $\{v, w\} \in E(X_i)$ one of the new vertex sets X_{i_0}, \dots, X_{i_m} contains both vertices. If $v, w \in S$, then this is trivially true. Otherwise, suppose $v \in Y_{i_j}$ for some $j \in \{1, \dots, m\}$. If $w \in Y_{i_k}, k \neq j$, then S does not separate Y_{i_j} and Y_{i_k} ; a contradiction. And thus, $w \in Y_{i_j} \cup S = X_{i_j}$. Condition (iii) states that all nodes in the tree that contain the same vertex v must form a subtree. We only need to check this for $v \in X_i$. If $v \in S$ then v is contained in all new nodes and the condition is trivially satisfied. Otherwise let $v \in Y_{i_j}$ for some $j \in \{1, \dots, m\}$. By construction, nodes $k \in N(i)$ and i_j are connected if X_k and Y_{i_j} intersect. Hence, all nodes that contain v form a subtree again.

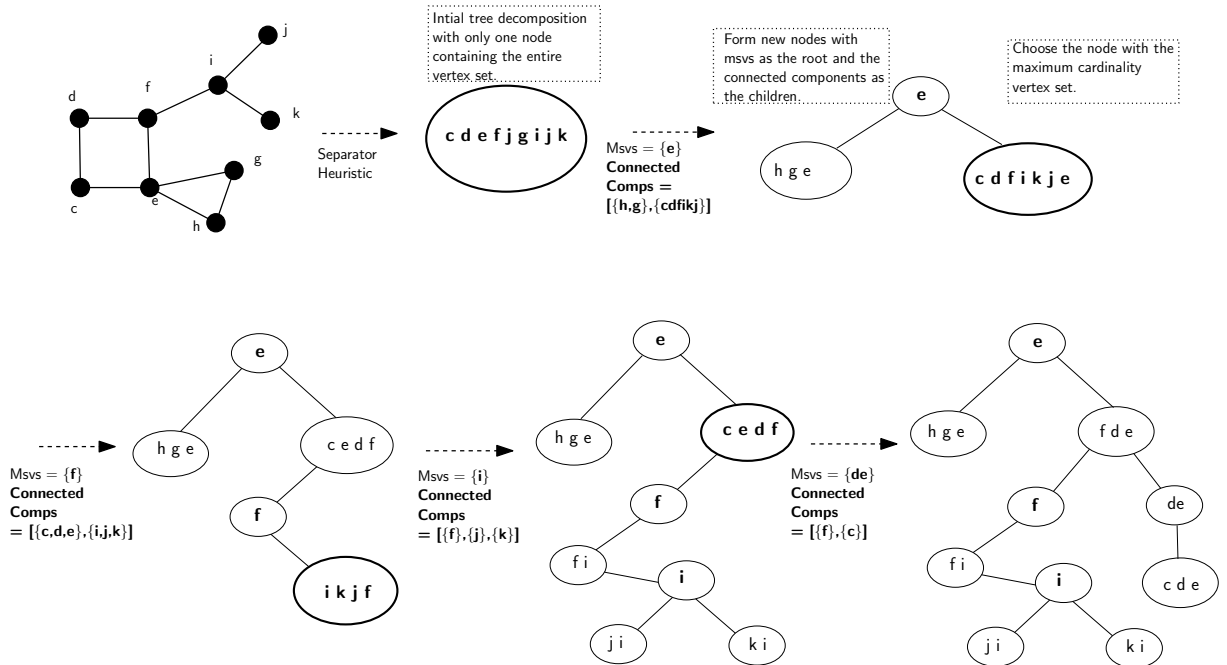

Figure 2.5: Construction of Tree Decomposition by MSVS

Note that, if H is not a clique, then there exist vertices $v, w \in X_i$ with $\{v, w\} \neq E(H)$. Thus $S = X_i \setminus \{v, w\}$ separates H in two components; $Y_{i_1} = \{v\}$ and $Y_{i_2} = \{w\}$. So, $\max\{|Y_{i_1} \cup S|, |Y_{i_2} \cup S|\} = |X_i| - 1 < |X_i|$. As a consequence, the width of the tree decomposition may decrease [16].

The width of the resulting tree decomposition may not be optimal. However, as long as the separating vertex sets S form cliques in the original graph, the algorithm provides optimal result, since the optimal tree decomposition will contain a node for every clique that separates the graph in multiple components.

In the following, we describe a pseudo-code implementation of the heuristic.

Algorithm 2.1 MSVS Heuristic [18]

Require: Initial tree decomposition (T, χ)

Ensure: modified tree decomposition $(\bar{T}, \bar{\chi})$ with $tw((\bar{T}, \bar{\chi})) \leq tw(\bar{T}, \bar{\chi}())$

```

1: while  $\exists i \in I : |X_i| \equiv \max_{j \in I} |X_j|$  and  $H = (X_i, E(H))$  non-complete with  $E(H) = \bigcup_{k \in N(i)} C(X_i \cap X_k) \cup E_G[X_i]$  do
2:    $N_{old}(i) := N(i)$                                 {store old neighbors of  $i$ }
3:    $F := F \setminus \{ij : j \in N_{old}(i)\}$             {disconnect  $i$  from tree}
4:   let  $S \subset X_i$  be a minimum separating vertex set in  $H$ 
5:   Let  $q$  be the number of components of  $H[X_i \setminus S]$ 
6:    $n := |I|$                                           {current number of nodes}
7:    $I := I \cup \{n + 1, \dots, n + q\}$                 {construct  $q$  new nodes}
8:    $F := F \cup \{ij : j = n + 1, \dots, n + q\}$       {connect new nodes with  $i$ }
9:   for  $p = 1$  to  $q$  do
10:    let  $Y_p \subset X_i$  be the set of vertices in component  $p$  of  $H[X_i \setminus S]$ 
11:     $X_{n+p} := Y_p \cup S$                              {define new vertex subsets}
12:   end for
13:    $X_i := S$ 
14:   for  $j \in N_{old}(i)$  do
15:     if  $\exists P \in \{1, \dots, q\}$  with  $X_j \cap Y_p \neq \emptyset$  then
16:        $F := F \cup \{n + p, j\}$                        {reconnect old neighbors}
17:     else
18:        $F := F \cup \{i, j\}$                            {reconnect old neighbors}
19:     end if
20:   end for
21: end while

```

2.3.3 Random Separator Vertex set Heuristic (RSVS)

As described in Chapter 4, building tree decompositions using the minimum separator vertex set heuristic (MSVS) is quite expensive. This is mainly because finding minimum separator of a graph is time consuming. It is evident from line 4 of algorithm 2.1 that to build the tree decomposition using this heuristic, the program needs to compute minimum separator of a subgraph a number of times which leads to a high running time of the entire program.

In this aspect, we decided to find techniques through which this high running time can be reduced. One such approach was to find a random separator of a set instead of a minimum separator. In this method, instead of considering all non-adjacent vertex pairs of a graph, we consider only a handful of non-adjacent vertex pair. The resultant separator may not be minimum but it greatly reduces running time as the algorithm now deals with only a few non-adjacent vertex pairs. We built another algorithm which is similar to 2.1. The only change is in Line 4 where the new algorithm will find a random separator instead of a minimum one. After experimenting on different graphs (details in Chapter 4), we found the results encouraging. This RSVS heuristic takes much less time than the MSVS approach and most of the time the quality of the tree decomposition is within an acceptable range.

Though we did not use the RSVS heuristic to generate tree decompositions for our research, but it has potential to be used in our future endeavors. As discussed in the section 1.3, we believe that this modified version of the separator heuristic will contribute significantly in developing the algorithm for partial tree decomposition where finding a balanced separator in quick time is crucial.

In the next section, we will begin describing the notations and definitions and later the algorithms for Clique Tree Heuristic.

2.4 Clique Tree Heuristic

This heuristic is based on the characteristics of *triangulated graph* or *chordal graph*. In this technique we discern a clique tree from a triangulated graph. We used the technique (for finding clique tree) developed by Habib, McConnell, Paul and Viennot [11]. They proposed an $O(n + m)$ (n = number of vertices, m = number of edges) algorithm to find a clique tree from a chordal graph given an elimination scheme.

2.4.1 Chordal Graph: Definitions and Characteristics

The following definitions and descriptions are based upon the work by Habib, McConnell, Paul, Viennot [11] and Koster, Bodlaender, Hoesel [18].

A graph is called **Chordal** if every cycle of length at least four contains a chord, that is, two non-consecutive vertices on the cycle are adjacent. A chordal graph is also a perfect graph.

Chordal graphs are characterized by the existence of **perfect elimination ordering** of their vertices, which is defined as follows. A *clique* is a set of vertices inducing a complete subgraph. An ordering x_1, \dots, x_n of vertices is a perfect elimination ordering of a graph $G = (V, E)$ if the neighborhood of each vertex x_i is a clique of the induced subgraph G_{x_i, \dots, x_n} . There exists an arrangement of maximal cliques in an chordal graph such that the maximal cliques containing a given vertex always induces a connected subtree. Our target is to find this clique tree which will also serve as a tree decomposition of the graph. The following properties are described in detail in respect to the target.

Theorem 2 (Gavril [10]). *A graph $G = (V, E)$ is triangulated if and only if G can be constructed as the intersection graph of subtrees of trees, i.e., there exists a tree $T = (I, F)$ such that one can associate a subtree $T_v = (I_v, F_v)$ of T with each vertex $v \in V$, such that $vw \in E$ if and only if $I_v \cap I_w \neq \phi$.*

To state this definition in a different way, a graph is triangulated if and only if there exists a tree

decomposition with the additional property that $vw \in E$ if and only if $I_v \cap I_w \neq \Phi$. This additional property guarantees that the tree decomposition has minimal width. Let $X_i := \{v \in V : i \in I_v\}$. Non-adjacent vertices are not in a common subset X_i . Hence, a maximum cardinality subset X_i contains the vertices of a maximum cardinality clique C in G . Since it also holds that in any tree decomposition (T, χ) and every maximum clique C , there exists a node $i \in I$ with $C \subseteq X_i$, the tree decomposition has minimum width. Moreover, it follows that the treewidth of a triangulated graph equals the maximum clique number minus one, $tw(G) = \omega(G) - 1$.

Lemma 1. For every graph $G = (V, E)$, there exists a triangulation of G , $\bar{G} = (V, E \cup E_t)$, with $tw(G) = tw(\bar{G})$

Proof. Let G be a general graph and (T, χ) a tree decomposition of minimum width. We construct a graph $\bar{G} = (V, \bar{E})$ by the following rule: $vw \in \bar{E}$ if and only if $v, w \in X_i$ for some $i \in I$. From Theorem 2 it is clear that \bar{G} is triangulated. From the second condition (from section 2.1) of a tree decomposition, the edge set \bar{E} can be divided into two parts E and E_t . So, \bar{G} is a triangulation of G by the addition of the *triangulation edges* E_t . Moreover, the treewidth of G and \bar{G} is equal, $tw(G) = tw(\bar{G})$.

□

Corollary 1. Finding the treewidth of a graph G is equivalent to finding a triangulation \bar{G} of G with minimum clique size.

Since finding the treewidth of a graph is *NP*-hard, also finding a triangulation with minimal clique number is an *NP*-hard problem. The maximal clique number (minus one) of any triangulation \bar{G} of a graph G provides an upper bound on the treewidth. Moreover, $\omega(\bar{G})$ can be computed in polynomial time.

There exists several algorithm which can convert any graph into its triangulated (or chordal) equivalent and also provides us the elimination order. We will use an algorithm called the Minimum degree heuristic [2] to triangulate a graph and find its elimination order. Then given the elimination scheme we will use the clique tree algorithm [11] to build a clique tree (also a tree decomposition)

of the triangulated graph. Since, the treewidth of a graph and its triangulated equivalent is the same, the tree decomposition of the triangulated graph is also a valid tree decomposition of the original graph.

2.4.2 Minimum Degree Heuristic

The *Minimum degree algorithm*(MD) is widely used as one of the heuristic for computing a triangulation of a graph. The algorithm is based on the algorithm called *Elimination Game*(EG), developed by S. Parter [24]. EG simulates Gaussian elimination on graphs by repeatedly choosing a vertex and adding edges to make its neighborhood into a clique before removing it. The resulted graph is always a triangulated graph. MD is observed [3] to produce triangulations which are often minimal or close to minimal. The following definitions, notations are based on the work done by Berry, Heggernes and Telle [2].

Given a graph $G = (V, E)$, we denote $n = |V|$ and $m = |E|$. For any subset S of V , $G(S)$ denotes the subgraph of G induced by S . We define $H = G + \{e\} + \{x\}$ when H is obtained from G by adding edge e and vertex x . For any vertex v of G , $N_G(v)$ denotes the neighborhood of v in G , and $N_G[v]$ denotes the set $N_G(v) \cup \{v\}$. For a given set of vertices $X \subset V$, $N_G(X) = \cup_{v \in X} N_G(v) \setminus X$ and $N_G[X] = \cup_{v \in X} N_G(v) \cup X$. A function $\alpha : V \rightarrow \{1, 2, \dots, n\}$ is called a *ordering* of the vertices of $G = (V, E)$, and (G, α) will denote a graph G , the vertices of which are ordered according to α . We will use $\alpha = (v_1, v_2, \dots, v_n)$, where $\alpha(v_i) = i$.

Algorithm 2.2 Elimination Game [2]

Require: A graph $G = (V, E)$, and an ordering α of the vertices in G

Ensure: A triangulation G_α^+ of G

- 1: $G_\alpha^1 \leftarrow G$
 - 2: $G_\alpha^+ \leftarrow G$
 - 3: **for** $k = 1$ to n **do**
 - 4: Let F be the set of edges necessary to saturate $N_{G_\alpha^k}(v_k)$ in G_α^k
 - 5: $G_\alpha^{k+1} \leftarrow G_\alpha^k + F - \{v_k\}$
 - 6: $G_\alpha^+ \leftarrow G_\alpha^+ + F$
 - 7: **end for**
-

In the algorithmic description of EG, $G_\alpha^k(\{v_k, \dots, v_n\} \setminus N_{G_\alpha^k}[v_k])$ is the *section graph at step k*. For any distinct $i, j \in [k, n]$, edge $v_i v_j$ is present in G_α^k iff there is a path in G between v_i and v_j (the path may have only one edge) all intermediate vertices of which are numbered $< k$ (i.e. do not belong to G_α^k). Similarly, the edges added during an execution of EG are well defined as $v_i v_j$ is an edge of G_α^+ iff $v_i v_j$ is an edge of G or there is a path in G between v_i and v_j , all intermediate vertices of which have a number which is strictly smaller than $\min\{i, j\}$.

The Minimum Degree Heuristic is based on EG: it takes as input an unordered graph G , and computes and ordering α along with the corresponding triangulation G_α^+ , by choosing at each step a vertex of minimum degree in G_α^k and numbering it as v_k .

In the next section we will describe the clique tree algorithm which utilizes the triangulated graph and the elimination order computed by this MD heuristic.

2.4.3 *Clique Tree Algorithm*

While working with lexicographic breadth first search (Lex-BFS) and partition refinement Habib, McConnell, Paul and Viennot [11] came up with a simple but efficient algorithm to find the maximal cliques from a triangulated graph. The following definitions, notations, algorithms and proofs are based on the narrative by the mentioned authors.

Before we describe the algorithm, we define below $RN(x)$, the right neighborhood of x . Given a graph G and an elimination order π , we define $RN(x)$ to be the neighbors to the right of x , namely, the set, $\{y : y \in N(x) \text{ and } \pi(y) > \pi(x)\}$. G is triangulated if and only if there exists a perfect elimination order [9]. An algorithm can be devised to recognize triangulated graphs. Given the elimination order π , this algorithm checks whether this ordering is a perfect elimination ordering or not. The algorithmic description is given below-

Algorithm 2.3 Chordality test [11]

Require: a graph $G = (V, E)$, and a ordering π of vertices

Ensure: TRUE if π is a perfect elimination ordering

```
1: for each vertex  $x$  do
2:   let  $RN(x)$  be its neighbors to the right
3:   let  $parent(x)$  be the leftmost member of  $RN(x)$  in  $\pi$ 
4: end for
5: Let  $T$  be the tree defined by the parent pointers
6: for each vertex  $x$  in  $T$  in postorder do
7:   check that  $(RN(x) \setminus parent(x)) \subseteq RN(parent(x))$ 
8: end for
9: if no check failed then
10:  return TRUE
11: end if
```

For the correctness, note that if π is a perfect elimination ordering, then $\{x\} \cup RN(x)$ is a clique, where x is its leftmost member and $parent(x)$ is its next leftmost member. The check obviously cannot fail. If it is not a perfect elimination ordering, then for some x , $x \cup RN(x)$ is not a clique. Without loss of generality, let x be the rightmost vertex in π with this property. By our choice of x , $parent(x)$ fails to have as a neighbor some vertex to its right that is a neighbor of x , so the check fails.

In the second for loop of Algorithm 2.3, it is checked whether $(RN(x) \setminus parent(x)) \subseteq RN(parent(x))$ or not. If the order π is indeed a perfect elimination order then this condition is true. We will prove this in the following. For each vertex x , $RN(x)$ is a subset of the ancestors of x in T . This is true for the root. Suppose it is true for any vertex at depth k , and assume that x is at depth $k + 1$. The parent of x is the earliest member of $RN(x)$ in π . Since $RN(x)$ is a clique, $RN(x) \setminus parent(x)$ is a subset of $RN(parent(x))$. By the inductive hypothesis, $RN(x) \setminus parent(x)$ is a subset of the ancestors of $parent(x)$.

We will now describe the algorithm for finding the clique tree, that is, to arrange the maximal cliques into a tree such that for each vertex, the subtree induced by the cliques that contain x are connected.

Algorithm 2.4 Clique Tree [11]

Require: G is a triangulated graph, and π is a perfect elimination ordering

Ensure: A clique tree τ of G

Let T be defined as in Algorithm 2.3

Let r be the root of T

for for each vertex x in T except the root, in preorder **do**

if $(RN(x) \setminus parent(x) \neq RN(parent(x)))$ **then**

 create a new clique $C = \{x\} \cup \{RN(x)\}$

$C(x) \leftarrow C$

$parent(C) \leftarrow C(parent(x))$

else

$C(parent(x)) \leftarrow C(parent(x)) \cup \{x\}$

$C(x) \leftarrow C(parent(x))$

end if

end for

It can be easily proven that for the same clique, the property $(RN(x) \setminus parent(x) = RN(parent(x)))$ is true. Finally, we show that after each vertex is processed, the parent relation is a clique tree on the subgraph induced by the set of processed vertices. To do this, we show that for an arbitrary processed vertex y , the cliques containing y induce a connected subtree of this tree. As a base case, it is true just after y is processed, since it is contained in only one clique of the tree. Suppose it is true just before some subsequent vertex x is processed. If no new clique containing y is created, it continues to be true. So assume that processing x creates a new clique C and y is contained in C . It suffices to show that the parent of C is a pre-existing clique that contains y . For each processed vertex z , $C(z)$ contains $\{z\} \cup RN(z)$. In particular, $C(parent(x))$ contains $\{parent(x) \cup RN(parent(x))\}$. Since $\{parent(x) \cup RN(parent(x))\}$ contains $RN(x)$, $C(parent(x))$ contains y . The parent of the new clique is a pre-existing clique containing y . It follows that the tree is a clique tree or a tree decomposition for G after all vertices are processed.

In Figure 2.4, a step by step construction of clique tree from an input graph is shown.

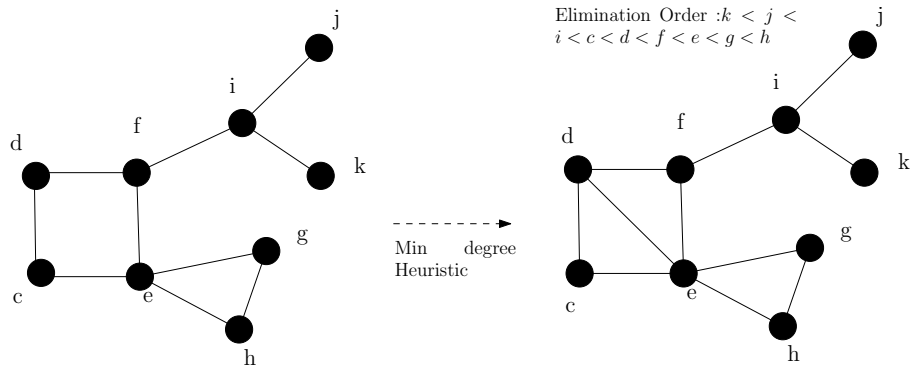

x	$RN(x)$
k	{i}
j	{i}
i	{f}
c	{d,e}
d	{f,e}
f	{e}
e	{g,h}
g	{h}
h	{}

Vertices and their Right Neighbourhood

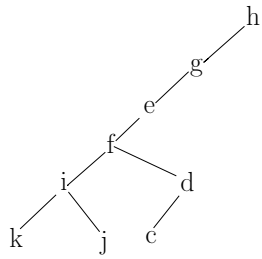

Tree defined by the parent pointers (x and $parent(x)$). Traverse this tree in Pre-order (root-left-right)



Keep adding vertex $x \in V$, in the same tree decomposition node if for x and $parent(x)$, $RN(x) \setminus parent(x) = RN(parent(x))$. It means the vertices inside the node are members of the same clique.

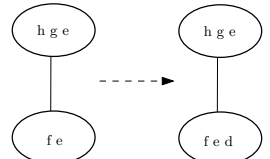

For vertices that are not in the same clique (in this case, for f , $RN(x) \setminus parent(x) \neq RN(parent(x))$), build a new node with the vertex set = $\{x\} \cup \{RN(x)\}$ (in this case the new node vertex set = $\{f\} \cup \{e\}$). Then for the next vertex check whether it belongs to the newly formed clique or not. If it is, then add in the same node like before (d is added in the new node).

End Result

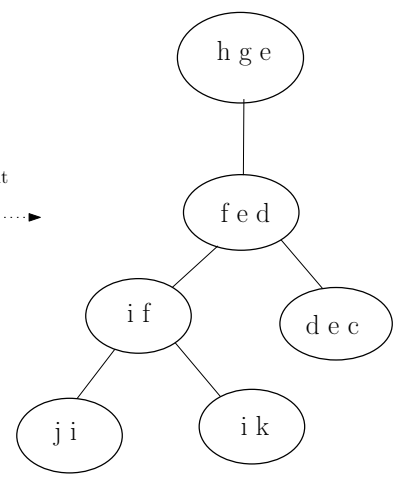

Figure 2.6: Step by Step execution of Clique Tree Heuristic

We have implemented both heuristics and experiments show (chapter 4) that clique tree heuristic is much faster than the minimum separator heuristic. Based on the results we decided to use the clique tree heuristic to compute the tree decomposition on which we will apply our dynamic programming algorithm. Details are described in the next chapter.

Chapter 3

Dynamic Programming Algorithm to Solve Covering Problem

Algorithms for covering problem on trees already exists [14]. In our research we extend dynamic programming on tree decompositions to build an algorithm to solve covering problem optimally on general graphs where the complexity is exponential in treewidth. In this chapter we describe the algorithm and various heuristic techniques to speed up the algorithm.

In section 3.1 we discuss a bottom up dynamic programming algorithm with its cost function definition. Then we describe the cost functions of four types of nodes of a special tree decomposition called nice tree decomposition. In section 3.2 we discuss techniques that reduce the number of entries in the cost tables in the dynamic program and speed up the running time. In section 3.3 we discuss a parallel algorithm which solves subproblems on different machines and a hybrid algorithm based on the dynamic programming algorithm where part of the tree decomposition is solved by an optimization software package called CPLEX. In the next section (3.4), we discuss brief implementation details of the algorithms and some implementation tricks which helped reduce the total run time.

3.1 Dynamic Programming Approach

As described in section 1.1, in a client constrained covering problem given n clients in a graph where each client has a radius r , the objective is to open facilities to cover these clients at a minimized cost. The two types of cost incurred here are the facility opening cost and the penalty cost for uncovered clients. Any arrangement of client facility allocation will yield a solution value. The optimal solution will have the lowest cost value.

Before we describe the dynamic program to solve the Covering problem, we discuss the notations and definitions required for the algorithm.

3.1.1 Cost function and other Definitions

Given a input graph $G = (V, E)$ and it's tree decomposition is a pair (T, χ) , (where $T = (I, F)$ is a tree with node set I and edge set F , and $\chi = \{X_i : i \in I\}$ is a family of subsets of V), for each tree decomposition node i , let us define X_i as the set $\{x_1 \dots x_k\}$ of graph vertices corresponding to the node. We define T_i , a subtree rooted at node i and G_{T_i} , a subgraph induced by the union of the vertices included in the nodes of T_i . Also, let $n = |V|$ and $m = |E|$ throughout the following sections.

Definition (Assignment Function). Let f be a function, $f : X_i \rightarrow V$, that maps every vertex in X_i to a vertex of the graph. For a vertex $x \in X_i$, $f(x)$ is the opened facility that is closest to x . This function will define a restricted covering problem on the subgraph induced by G_{T_i} . We also denote the entire facility allocation for a node X_i , by f_{X_i} .

We say that a client $x \in X_i$, is covered by a facility $f(x)$, if the shortest path distance between x and $f(x)$, defined as $d(x, f(x))$ is less than or equal to the client radius r . When a facility $f(x)$ is opened, then an opening cost $c_{f(x)}$ is incurred. Likewise, when a client, $x \in X_i$, is not covered by any opened facility, then a penalty cost b_x is incurred. The following cost function definition is similar to those defined by Arie Tamir in his study of P-median problem on trees [29].

Definition (Recursive Cost Function). We define the cost function as $\Phi(X_i, f(x))$, that denotes the cost value for the covering sub-problem defined on the subgraph G_{T_i} with the constraint that $f(x)$ is the closest open facility to x , for all $x \in X_i$. The cost value for this function is equal to the sum of the opening cost of the facilities opened inside or outside the subgraph G_{T_i} and the sum of the penalties paid for any uncovered client in the subgraph G_{T_i} . The optimal value of the sub-problem defined on the subgraph G_{T_i} can be found by taking the minimum cost functions over all possible allocation functions $f(x)$.

As we are employing a nice tree decomposition, there are only four types of nodes present in the tree decomposition. In the following subsections, for each types of node, a set of recursive cost functions are defined. As this is a leaves to root dynamic program, the solution propagates from leaves to root. Each node has a cost table associated with it which contains a cost function entry for

every possible facility configuration to serve the client set contained in the node. After the program ends, the root contains the optimal solution.

3.1.2 Leaf Node

Let i , where $i \in I$ be a leaf node. According to the nice tree decomposition properties, X_i contains a single vertex x , that is, $X_i = \{x\}$. Two cases are possible for this type of node.

Case 1 If the single vertex x is covered by a facility $f(x)$ then the facility opening cost will be added to the cost function. So, for $d(x, f(x)) \leq r$, the recursive cost function for leaf node becomes

$$\Phi(\{x\}, f(x)) = c_{f(x)}$$

Case 2 If the client x is not covered by the assigned facility $f(x)$ then a penalty must be paid and as such a penalty cost is added to the cost function. The cost function becomes

$$\Phi(\{x\}, f(x)) = c_{f(x)} + b_x$$

Except leaf node, every other node's cost functions depends on its child node's cost function. For a parent node i and its child node j , Let us define another assignment function $g, g : X_j \Rightarrow V$, that maps every vertex in X_j to a vertex of the graph. It is similar to the assignment function f . Given the assignment functions f and g for the parent node i and child node j , Let \mathcal{G}_f be the set of facility allocations functions at the child node X_j that have the same image as functions f on the set $X_i \cap X_j$. Formally,

$$\mathcal{G}_f = \{g : X_j \rightarrow V \mid g(x) = f(x) \text{ for all } x \in X_i\}$$

The following figure shows four pieces of the nice tree decomposition from figure 2.4, where each piece describes a different nice tree decomposition node. It also shows the relation between facility assignment functions f and g at the parent and child node.

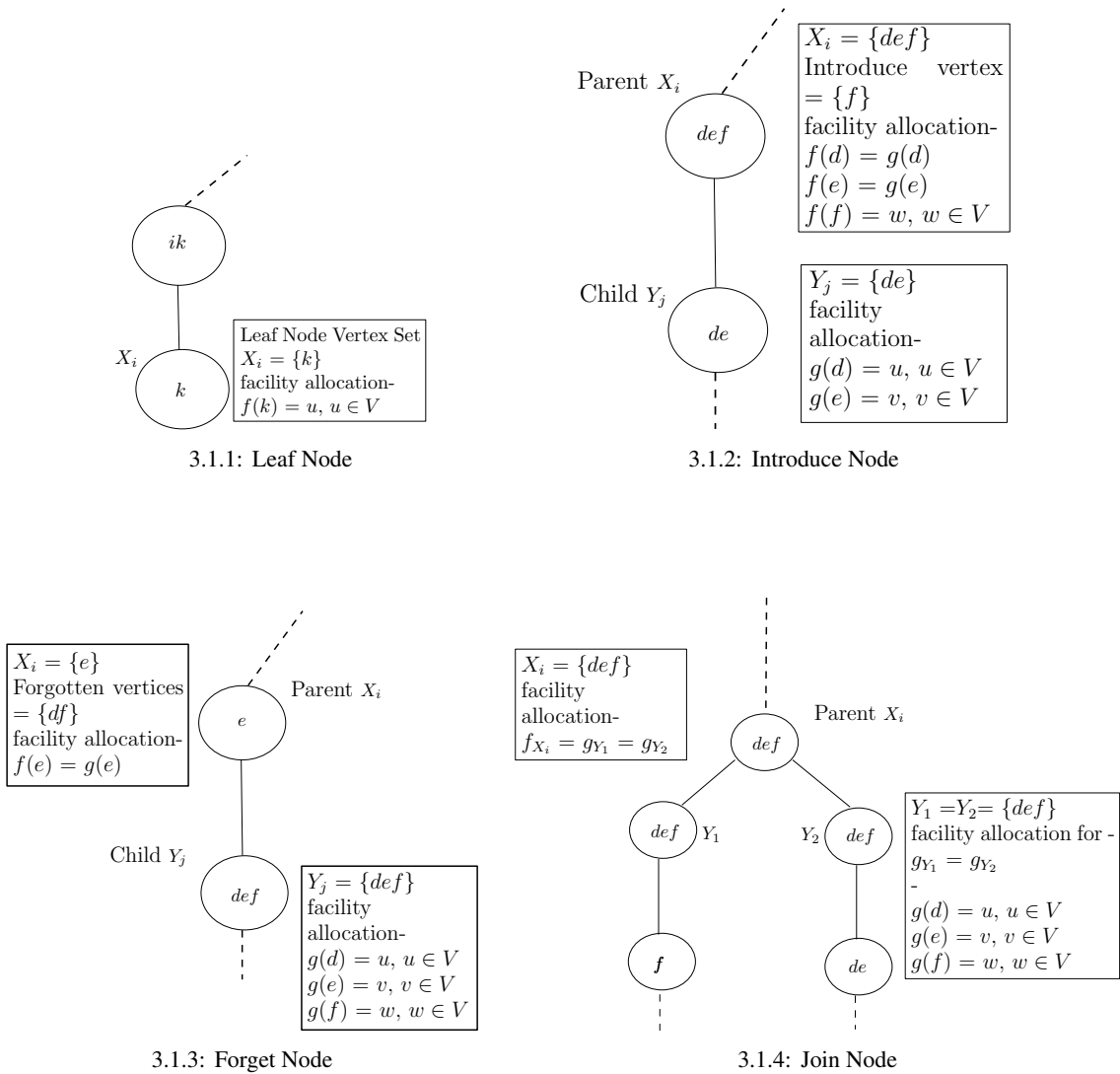

Figure 3.1: Different types of Nice Tree Decomposition nodes with their facility allocation

3.1.3 Introduce node

Let i , where $i \in I$, be an introduce node. According to the definition of **Introduce** Nodes, if the child node is j , where $j \in I$ and $X_j = (x_2 \dots x_k)$, then $X_i = X_j \cup \{x_1\}$, where x_1 is the extra or introduced vertex in node i . The facility serving x_1 is $f(x_1)$, which can be any vertex in the graph, including x_1 . The other vertices $(x_2 \dots x_k)$ are serviced by the facility set $\{f(x_2) \dots f(x_k)\}$ whose costs are already computed at the child node j . Two cases are possible based on the criteria whether $f(x_1)$ is already

opened or about to be opened.

Case 1 The facility $f(x_1)$ is not already opened, which means $f(x_1) \notin \{g(x_2) \dots g(x_k)\}$. Suppose x_1 is covered by $f(x_1)$, thus $d(x_1, f(x_1)) \leq r$. The value of the cost function is the addition of the opening cost of facility $f(x_1)$ and the cost of the subproblem (with the facility configuration $\{g(x_2) \dots g(x_k)\}$ defined on the subgraph $G(T_{X_j})$). The cost function becomes

$$\Phi(X_i, (f)) = \Phi(X_j, (g)) + c_{f(x_1)}$$

If x_1 is not covered by $f(x_1)$ that is $d(x_1, f(x_1)) > r$, then a penalty cost must be paid. The cost function becomes

$$\Phi(X_i, (f)) = \Phi(X_j, (g)) + c_{f(x_1)} + b_{x_1}$$

Case 2 The facility $f(x_1)$ is already opened at the child node X_j which is covering x_1 , which means, $f(x_1) \in \{g(x_2) \dots g(x_k)\}$ and $d(x_1, f(x_1)) \leq r$, the cost function for node X_i is the same as the cost for it's child X_j as the facility $f(x_1)$ has already been opened at the child node. The cost function becomes

$$\Phi(X_i, (f)) = \Phi(X_j, (g))$$

Again, if x_1 is not covered by $f(x_1)$ that is $d(x_1, f(x_1)) > r$, then a penalty cost must be paid. The cost function becomes

$$\Phi(X_i, (f)) = \Phi(X_j, (g)) + b_{x_1}$$

3.1.4 Forget Node

Let i , where $i \in I$, be a Forget node. According to the definition of **Forget** Nodes, if the child node is j and $X_j = \{x_1, \dots, x_k\}$ then $X_i = X_j \setminus \{x_1\}$, where x_1 is the forget vertex in Node i .

Given the facility allocation $f : X_i \Rightarrow V$ for forget node i and $g : X_j \Rightarrow V$ for the forget node's child j , computing the cost function at i requires to find the minimum cost function from child node j over all cost functions $\{\Phi(X_j, g) : g \in \mathcal{G}_f\}$. The cost function for forget node becomes -

$$\Phi(X_i, (f)) = \min\{\Phi(X_j, (g)) : g \in \mathcal{G}_f\}$$

3.1.5 Join Node

Let i , where $i \in I$, be a Join node. if node i has t children, $j_1, j_2 \dots j_t$, then according to the definition of **Join** Nodes, the nodes i, j_1, j_2, \dots, j_t have the same vertex set, that is $X_i = X_{j_1} = X_{j_2} = \dots = X_{j_t} = (x_1 \dots x_k)$. Because of this reason, the facility allocation for join node i and for all it's children, $j_1, j_2 \dots j_t$ will be the same, that is $f_{X_i} = g_{X_{j_1}} = g_{X_{j_2}} = \dots = g_{X_{j_t}}$. The cost function value at node i will be equal to the sum of the cost values of the subproblem defined on the subgraphs $G_{T_{j_1}}, G_{T_{j_2}} \dots G_{T_{j_t}}$. As all the children has the same vertex set and the same f , the covering cost which includes opening costs and penalties for client vertices in set $X_i = X_{j_1} = X_{j_2} = \dots = X_{j_t}$, will be repeated in the final cost value. So, the repeated cost is deducted $t - 1$ times, where t is the number of children for a Join node. The recursive cost function becomes

$$\begin{aligned} \Phi(X_i, (f)) = & \Phi((X_{j_1}, (g))) + \Phi((X_{j_2}, (g))) + \dots + \Phi((X_{j_t}, (g))) \\ & - \sum_1^{t-1} \left\{ \sum_{x \in X_i} \kappa(x, f) \right\} \end{aligned}$$

Here, $\kappa(x, f)$ is a function which computes the covering cost for a pair $(x, f(x))$, where $x \in X_i$ and $f(x) \in f_{X_i} = \{f(x_1) \dots f(x_k)\}$, the facility assignment vector for node i and also for it's children j_1, j_2, \dots, j_t . The function $\kappa(x, f)$ can be defined as

$$\kappa(x, f) = \sum_{x \in X} \rho(x, f(x)) + \sum_{y \in f(X)} C_y$$

Where $\rho(x, f(x))$ can also be defined as a function

$$\rho(x, f(x)) = \begin{cases} 0, & \text{if } d(x, f(x)) \leq r_x \\ b_x, & \text{if } d(x, f(x)) > r_x. \end{cases}$$

This function computes the penalty cost for a pair $(x, f(x))$.

3.1.6 *Running Time*

For each tree decomposition node the cardinality of the vertex set is at most $k + 1$, where k is the treewidth. For a tree node i , the number of possible cost functions is n^{k+1} , where n is the number of vertices of the original graph. In the worst case, to compute for a parent node i , we need to generate n^{k+1} possible cost functions $\Phi(X_j, f)$ at the child node j , one for each n^{k+1} assignment function f , as defined in Section 3.1.1. Each of the cost function entry can be accessed in a constant time from the cost table. If we look into the cost function equation from the earlier sections then we can determine a upper bound on the running time for processing cost functions for different types of nodes. In case of join node, if it has t number children then to process each cost function, we need to access t number of cost function, one for each child. So, the running time for a join node cost function is bounded by t . For forget node, to process a cost function, we need to access at most n number of cost functions from the child node, where n is the number of vertices in the input graph. So, the running time to process a forget node cost function is bounded by n . For introduce and leaf node, it takes constant time to each of their cost functions. So, the running time to process a single cost function is no more than n . As there are n^{k+1} number of possible cost functions per node, for a single node the running time is bounded by n^{k+2} . In a tree decomposition there can be at most $O(n)$ number of tree nodes. So, in the worst case the total running time is n^{k+3} . However, with amortized analysis we can improve this running time a bit. For join and forget node, it is described earlier that their running time is bounded by t and n . These bounds directly depends on the usage of cost function of their children. In case of a child of a join node, it is evident that each cost function of the child node is used once at the join node. So, in total each cost function generated at a child of join

node is used twice, once at the node that it is generated and next it is used at the join node. Same holds true for introduce and forget node's child as well. So, we can say that the usage for each cost function generated any node is no more than 2. Now, let us reanalyze the running time. For each node, the total number of operations for the generated cost functions is $2n^{k+1}$. Again, as there are $O(n)$ number of nodes, the total number of operations becomes $2n^{k+2}$. In this term, the previous bounds t and n disappears as they are replaced by a constant. Using the big-oh notation, the running time becomes $O(n^{k+2})$.

3.1.7 Proof of Correctness

The dynamic program that we discussed earlier has a optimal substructure. Let us define the following notations for the proof. Given an input graph $G = (V, E)$ and its tree decomposition (T, χ) , let OPT be the set of all possible solutions to the Covering problem on this graph. Let Y_{OPT} be one of the optimal solution from the set OPT which comprises a list of open facilities and the optimal cost value. Let $f_{Y_{OPT}}, f_{Y_{OPT}} \subseteq Y_{OPT}$ be the set of facilities that covers G_{T_i} when we restrict the optimal solution Y_{OPT} to the subproblem G_{T_i} . The restricted solution will only contain the opened facilities from Y_{OPT} that cover clients in the subgraph under consideration. The cost value computation for the restricted solution remains the same, that is the sum of opening cost and the sum of penalties for the uncovered clients. For any node i and its client set X_i , let G_{T_i} be the subgraph defined by the subtree T_i rooted at node i . We will prove the following-

Theorem 3. *Given an optimal solution Y_{OPT} , for any node i , let $C(Y_{OPT_{X_i}})$ be the cost value produced by the solution provided by Y_{OPT} if it is restricted to the subproblem G_{T_i} . Then the cost function $\Phi(X_i, (f_{Y_{OPT}}))$ at node i will have the cost value $C(Y_{OPT_{X_i}})$ and will be optimal to the subproblem defined by G_{T_i} with respect to the entire problem.*

Proof.

In figure 3.2 an arbitrary node i with client set X_i of a tree decomposition is shown. For simplicity

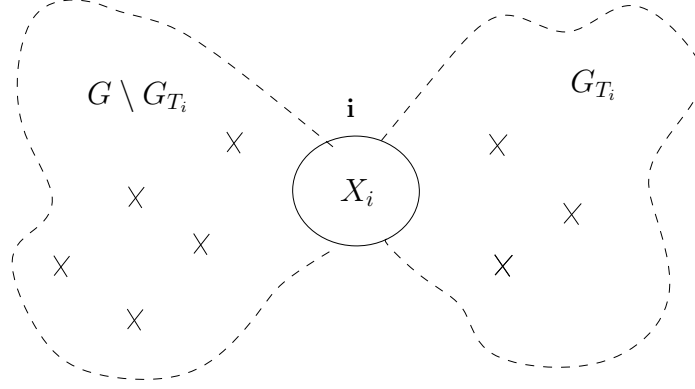

Figure 3.2: Subtree G_{T_i} and $G \setminus G_{T_i}$ at node i

the subtree T_i of node i and the rest of tree $T \setminus T_i$ is depicted as a subgraph G_{T_i} and $(G \setminus G_{T_i})$ defined by them. Now, Let us restrict the solution Y_{OPT} to the subproblem defined by the subgraph G_{T_i} .

When we restrict Y_{OPT} to the subproblem defined by G_{T_i} , we define the restricted solution as $Y_{OPT_{G_{T_i}}}$, the cost value as $C(Y_{OPT_{X_i}})$ and the facility allocation given by the restricted solution as $f_{Y_{OPT}}$. For all cost functions at node i defined by $\Phi(X_i, (f))$, one of the cost functions will have the same facility configuration as the $f_{Y_{OPT}}$. We define this cost function as $\Phi(X_i, (f_{Y_{OPT}}))$. We claim that the cost value generated by the cost function $\Phi(X_i, (f_{Y_{OPT}}))$ is equivalent $C(Y_{OPT_{X_i}})$, that is this cost function is optimal for set X_i , as well as for the subproblem defined by G_{T_i} .

We will use the proof by contradiction to prove our claim. As described earlier, the optimal solution defined by the cost function $\Phi(X_i, (f_{Y_{OPT}}))$. Some other solution in G_{T_i} that produces a suboptimal cost value at node i may yield a better result than $f_{Y_{OPT}}$ by covering more clients in subgraph $(G \setminus G_{T_i})$ thus reducing the overall cost. This means that at least one facility p from G_{T_i} not in the set $f_{Y_{OPT}}$ covers at least one client z from $(G \setminus G_{T_i})$. The shortest path between p and z must go through one of the clients in X_i as according to the definition of tree decomposition, X_i is a separator that connects G_{T_i} and $(G \setminus G_{T_i})$. Again, by definition, the facilities in $f_{Y_{OPT}}$ are closest to the clients in X_i as $f_{Y_{OPT}}$ is optimal for node i . So, any other facility configuration other than $f_{Y_{OPT}}$ cannot have more covered clients in $(G \setminus G_{T_i})$. So, $f_{Y_{OPT}}$ is optimal for node i as well as for the subproblem G_{T_i} and

will eventually form the optimal solution Y_{OPT} in the end.

It is proven that the optimal solution to the whole problem contains within it the optimal solution to the subproblem.

□

3.2 Heuristic Techniques

The brute force dynamic programming approach which is discussed in the earlier section solves the Covering problem optimally but its running time is exponential when the treewidth is unbounded. As shown by our experiments on series parallel graphs¹ of small size. The experiment results showed a high running time because of the high memory consumption of the algorithm. More details on the experiments are further discussed in the next chapter.

To counter this problem, we developed some heuristic techniques which greatly reduced the number of entries in the cost table. We describe these techniques below.

3.2.1 Pruning Heuristic

In the brute force approach, suppose for a tree node i , X_i contains p number of vertices. As mentioned earlier in Section 3.1.6, p can be at most $k + 1$, where k is the treewidth. Now, for a given client set $X_i = \{x_1, x_2 \dots x_p\}$, the facility allocation is $f_{X_i} = \{f(x_1), f(x_2) \dots f(x_p)\}$. The number of cost functions is equal to the number of possible facility assignment functions over set X_i . Computing the cost functions reduces to enumerating the permutations with repetitions of choosing p elements from n . The number of such permutations are n^p . Thus each cost table has n^p entries which is very high in practice. In order to compute whether a client is being covered by a facility or not, the dynamic program computes all pair shortest path distances of the input graph G . The

¹treewidth not more than 2

heuristic utilizes this already computed information.

According to the definition of assignment function f , defined in Section 3.1.1, for a vertex $x \in X_i$, $f(x)$ is the opened facility that is closest to x . For a valid cost function, the client-facility mapping obeys this relation. Our heuristic checks whether every possible facility configuration abide by the definition of assignment function f or not. For a given facility configuration f_{X_i} , the heuristic checks whether there exists a client pair $(x_a, x_b) \in X_i$ for which $d(x_a, f(x_b)) < d(x_a, f(x_a))$, where $f(x_a), f(x_b) \in f_{X_i}$ and $a \neq b$. Then it simply discards that facility configuration and moves on to process the next. Thus for each node it checks for n^p possible facility configuration, where p is at most $k + 1$, mentioned in Section 3.1.6 and discards the entry of the cost function into the cost table when the facility configuration for that cost function violates the definition of f .

Through this technique, a great number of invalid entries are discarded and the size of the cost table reduces significantly. We ran a series of experiment which confirms this claim. The experiment results will be further discussed in detail in the next chapter. In the next section, we will discuss another heuristic technique that will reduce the number of cost functions at a node based on the Covering neighborhood of the node that remains at a proximity of the Covering radius.

3.2.2 Reductions of cost functions based on the Covering Neighborhood

Given a facility allocation and a client set, if for a client the closest facility is situated outside the covering radius, then no other facility will cover that client unless the client itself becomes a facility. So, for a client a potential facility to serve that client would be one of the members of it's covering neighborhood. The covering neighborhood for client x can be defined as below-

$$CN(x) = \{v: d(x, v) < R_x, R_x = \text{Covering Radius of client } x \}$$

Similarly, for any node i , the covering neighborhood for the node would be the union of covering neighborhood of the clients in X_i . Covering neighborhood of a node i can be defined as-

$$CN(i) = \{\cup_{k \in size(X_i)} CN(x_k)\}$$

For every facility that is situated outside the clients covering radius, a penalty is paid for the uncovered client. We can represent the set of the facility situated outside the covering radius of the client by a symbol ϵ . Then for any node i , we modify the set $CN(i)$ by adding the ϵ symbol in to the set-

$$CN(i) = \{\{\epsilon\} \cup CN(i)\}$$

For any node i , if we restrict the facility configuration permutation to the modified set $CN(i)$, then the final permutation set will encapsulate all the necessary scenarios that will likely to produce the optimal solution. The number of permutations is directly related to the client's covering radius. The bigger the covering radius, the larger is the set of permutations.

In this context, to reflect the changes on the number of facility configurations, we need to modify the assignment function. For any node i , instead of $f : X_i \rightarrow V$, the assignment function will be redefined as $f : X_i \rightarrow CN(i)$.

We also need to modify the cost functions for different types of nice tree decomposition nodes to capture the inclusion of ϵ symbol.

Leaf Node

Continuing from the section 3.1.2, we need to add another case for the Leaf Node cost function definition.

Case 3 When $f(x) = \epsilon$, then only a penalty cost need to be paid as $f(x)$ represents the set of facilities situated outside the client's covering radius. The cost function definition becomes-

$$\Phi(\{x\}, \epsilon) = b_x$$

Introduce Node

Continuing from section 3.1.3, we need to add another case for the introduce node, where we set $f(x_1) = \varepsilon$ to represent the set of facility situated outside the covering radius of the client.

Case 3 If $f(x_1) = \varepsilon$, then we are considering that x_1 is uncovered. So, only a penalty cost will occur in this case (without opening any facility).

$$\Phi(X_i, (\varepsilon)) = \Phi(X_j, (g)) + b_{x_1}$$

Forget Node

As we we only need to find the minimum cost function from the child node, we don't need to modify the cost function definition in this case.

Join Node

In case of join node, we also don't need to modify the cost function definition. We only need to modify the $\kappa(x, f)$ function which computes the covering cost for a pair $(x, f(x))$. This function is used to compute the repetition cost for the join node's children. The modified definition is given below-

$$\kappa(x, f) = \sum_{x \in X} \rho(x, f(x)) + \sum_{y \in f(X)} \phi(y)$$

Only the second part of the function $\kappa(x, f)$ is modified where $\phi(y)$ is another function which can be defined as-

$$\phi(y) = \begin{cases} C_y, & \text{if } y \text{ is a facility covering } x \\ 0, & \text{if } y = \varepsilon \end{cases}$$

By using this technique , the number of cost functions per cost table can be greatly reduced if the client covering radius is small. In practice this technique in coalition with the heuristic improves

the running time significantly.

3.2.3 Pruning Using Branch and Bound

The Branch and Bound technique is a well known method for solving various optimization problems, especially in discrete and combinatorial optimization. This method was first proposed by A. H. Land and A. G. Doig [20]. This approach is based on the principle that the feasible solution space can be partitioned into smaller subsets of solutions. Then each of these subsets can be evaluated until the best possible solution is found. This technique is often affiliated with the non integer solution where the integer constraints are relaxed to get a solution.

Considering the maximization problems (in our context) suppose the goal is to find the maximization of a function $f(x)$ of variables $(x_1 \dots x_n)$ over a region of feasible solution, S . The first step of the Branch and Bound procedure is *splitting* or *branching*, where given S (the feasible solution space), this procedure will generate two or more subproblems S_1, S_2 from S generally by adding new constraints. A subproblem hence corresponds to a subspace of the original solution space. This recursive process defines a search tree. The solution of a problem is described as a search through a search tree, in which the root node corresponds to the original problem to be solved, and other nodes corresponds to subproblem which satisfy the same constraints as the root and additionally a number of others. The next step in the Branch and Bound technique is called the *bounding* process where to each node in the tree a bounding function associates a real number called *bound* for the node. For leaves the bound equals the value of the corresponding solution, whereas for internal nodes the value is a lower bound for the value of any solution in the subspace corresponding to the node.

In order for the Branch and Bound technique to work, a feasible solution to the entire problem needs to be computed beforehand. For any integer program, a feasible solution can be produced by relaxing its integral constraints and solve the linear program. In other cases, the feasible solution can be produced by some advanced heuristic. This value will be used as the current best solution

and will be called the *incumbent*. In each iteration of a Branch and Bound algorithm, a node is selected for exploration from the pool of unexplored nodes. Two or more children of the node are constructed through the addition of constraints to the subproblem of the node. In this way the subspace is divided into smaller subspaces. For each of these the bound for the node is calculated. In case the bound is the value of an optimal solution, the value is compared to the incumbent, and the best solution and its value are kept. If the bound is no better than the incumbent, the subproblem is discarded or pruned, since no feasible solution of the subproblem can be better than the incumbent. In case no feasible solutions to the subproblem exists, the subproblem is also discarded. Otherwise that subproblem node is added to pool of unexplored nodes.

We will apply a modified version of this Branch and Bound Technique to prune the redundant cost functions in our algorithm. A similar branch and bound approach was used in the study of protein chain lattice fitting problem by Thomas Dallas as part of his M.Sc thesis [30]. As we discussed earlier, Branch and Bound Techniques has two steps, Splitting or Branching and Bounding. As we used a Tree Decomposition, we do not have to use the Branching step as the subproblems are already defined by the Tree Decomposition nodes. The general steps for our Branch and Bound Technique are-

- Find a feasible solution (an upper Bound) of the problem.
- Compute a lower bound for each cost function for every node of the Tree Decomposition.
- Compare the lower bound and the upper bound. If the lower bound $>$ upper bound, then discard the cost function.

In Figure 3.3, a symbolic representation of a Tree Decomposition is shown. The root node of the Tree Decomposition and another arbitrary node i at the middle is present in this figure. The node vertex set X_i of node i contains two vertices x_1 and x_2 . The subtree rooted at node i is T_i . The subproblem defined by the subtree between the root node and node i is denoted by G_s . Vertices a_1 , a_2 and a_3 is are part of G_s . The subproblem defined by the subtree at the root node denotes the entire

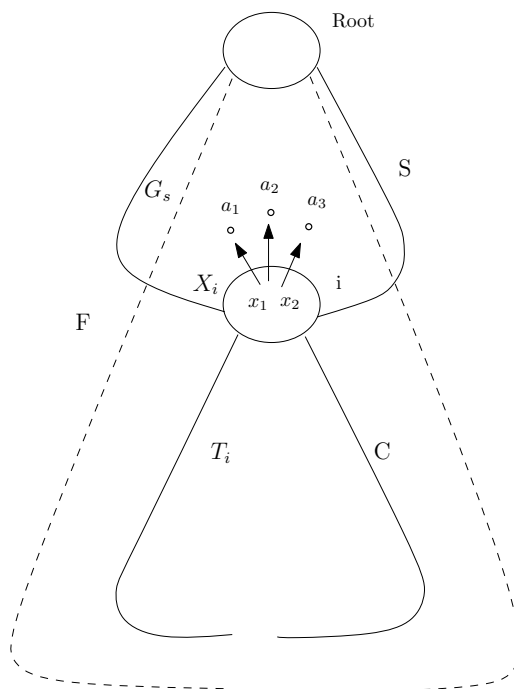

Figure 3.3: Tree Decomposition with Bounds

input graph G .

We chose CPLEX, a software tool designed to solve integer programming problems (more on section 3.3.1), to compute the feasible solution F for the problem. CPLEX solves the relaxed version of the Covering Problem as described in section 1.1. This solution value F will provide an upper bound for the Covering problem on the input graph.

As discussed earlier, for each Tree Decomposition, if the treewidth is k , then there can be n^{k+1} cost functions in the worst case. For each such cost function, we will compute a lower bound for the whole problem. For example, in Figure 3.3 at node i , there can be n^2 number of cost functions, as $|X_i| = 2$. Each such cost function will produce a cost value C (through dynamic programming computation) that represents the solution value of the Covering problem restricted to the subtree T_i rooted at i . To compute the lower bound, we need to have a feasible solution S of Covering Problem on the subproblem defined by G_s . Once S is computed, for each cost function (with cost value C)

at node i , the lower bound will be, $S + C$. Because S represents the feasible solution for G_s and C represents the cost value for the subgraph G_{T_i} and $G_s + G_{T_i} = G$. If for this specific cost function the lower bound $>$ upper bound, then the cost function is discarded, as it will never produce an optimal solution.

We use CPLEX like before, to solve the relaxation of the Covering problem restricted on the subgraph G_s to compute S . But In order to compute the correct lower bound, we need to remove the overlapping cost that may be included in C , the cost function value for any cost function at node i . In Figure 3.3, at node i with $X_i = (x_1, x_2)$, suppose a generated cost function permutation is (b_1, b_2) . That is the at b_1 and b_2 facilities are opened and they are serving (or paying the penalty if the clients are uncovered) the clients x_1, x_2 . These facilities b_1, b_2 may very well cover clients that are outside the subgraph G_{T_i} . Suppose a_1, a_2 and a_3 are such clients, who are part of the subgraph G_s but covered by the facilities b_1 and b_2 . For this cost function (b_1, b_2) , the solution value C of the Covering problem restricted at G_{T_i} , will include the clients a_1, a_2 and a_3 . While computing S , if these clients a_1, a_2 and a_3 are still part of the problem model defined by the subgraph G_s , then the solution may open facilities in any one these clients, which will be an extra cost as all these clients are already covered by the solution C . So, to remove such overlapping extra cost from S , for any node i , we will compute the set of clients that are outside the subtree T_i covered by the node vertex set X_i . Because the vertices in a node vertex set are undoubtedly the closest vertex to the clients present outside the subtree defined by that node (described in 3.1.7). So, the clients that are uncovered by the node vertex set X_i are also uncovered by any of the vertices inside T_i . Hence, for any vertices (facilities) present in the cost function permutation, the set of covered clients (by those facilities), will be a subset of the set of clients covered by the node vertex set. Removal of the set of covered clients(covered by the node vertex set) from the subgraph G_s while computing S , the produced lower bound will not be as tight as it could have been if the set of clients were covered by the facilities present in the cost function permutation. But in that case we have to compute S for each cost function at node i . In our way, we need to compute S only once per node.

The Branch and Bound technique prunes more cost functions than the pruning heuristic in most cases. But the computation of the bounds for each node is costly. More is discussed on the implementation section of this chapter.

3.3 Hybrid and Parallel Algorithm

We incorporated all the techniques with the dynamic programming algorithm described in the earlier section and wrote a program to run experiments. It performed really well comparing with the program with no heuristic techniques. We then used CPLEX, a software tool developed by IBM to check the correctness of our program. But we found that CPLEX is very efficient when it solves the Covering problem on the same data set and is much quicker than our algorithm. To reduce the difference between the running times, we then designed a Hybrid algorithm and a Parallel programming algorithm which uses the CPLEX and CONDOR GRID to facilitate the execution of the algorithm. We will discuss these algorithms in the following sections.

3.3.1 A Hybrid algorithm with CPLEX and Dynamic Programming

IBM ILOG CPLEX Optimization Studio (often informally referred to simply as CPLEX) is an optimization software package developed by IBM. The IBM ILOG CPLEX Optimizer solves integer programming problems, very large linear programming problems using either primal or dual variants of the simplex method or the barrier interior point method, convex quadratic programming problems, and convex quadratically constrained problems.

We used CPLEX mainly to check the correctness of our algorithm. But we found out that for our data set (more discussed in 4.2.1) CPLEX runs very fast. We incorporated all the techniques (heuristics and implementation techniques) in our algorithm, it did improve the running time considerably from last time, but still it's quite slow when compared to CPLEX. We then decided to incorporate the services of the CPLEX module in our algorithm, thus developing a Hybrid algorithm which has

both dynamic programming and CPLEX.

The reason the dynamic program is slow is because for each Tree Decomposition node it has to process a large number of cost functions in case of large graphs. The idea is to use CPLEX to solve a bottom chunk of the Tree Decomposition so that the dynamic program does not have to get stuck with a huge number of cost functions. The size of the chunk or subproblem will be supplied as command line parameter to the algorithm.

In Figure 3.4 the solution steps of a symbolic Tree Decomposition by the Hybrid algorithm is shown. The intuition behind this design is that, if the dynamic program has less number of nodes to work with then this hybrid algorithm will be faster than CPLEX in case of large graph instances.

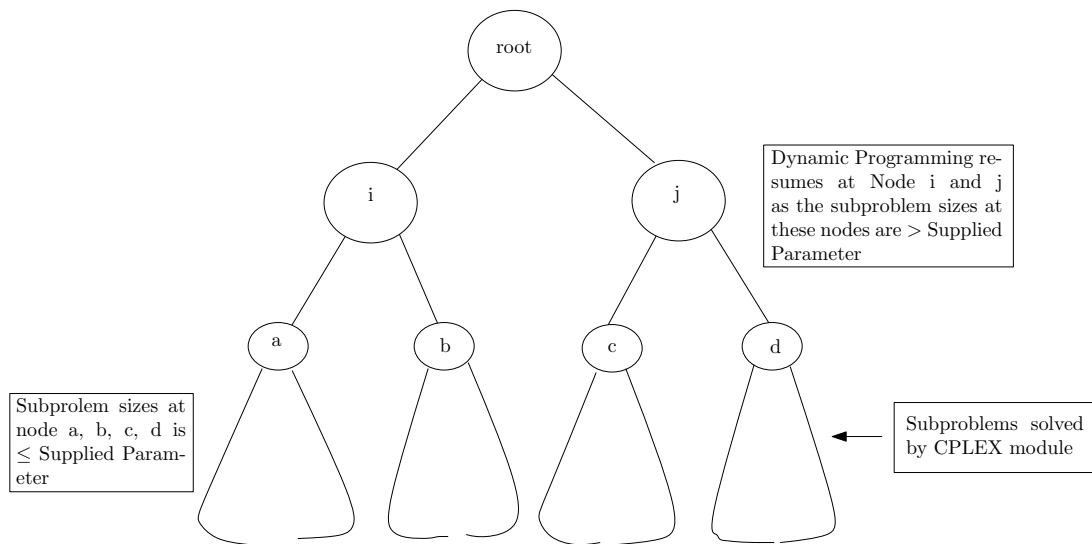

Figure 3.4: Solving a Tree Decomposition with the Hybrid Algorithm

The CPLEX part of this algorithm has two steps-

- Node selection
- Subproblem Solution

In the Node selection step, the nodes with the desired subproblem size is selected to be solved by CPLEX. As mentioned earlier, this subproblem size is controlled by a parameter called *target subproblem size*. Given a target subproblem size, the program traverses the Tree Decomposition the same way (bottom up traversal) it traverses for the dynamic programming algorithm. It also keeps track of the subproblem size defined by the subtree rooted at the node it is visiting. While traversing on a branch the most recent node that has a subproblem size less than or equal to target subproblem size is selected for CPLEX. In Figure 3.6, on the leftmost branch, node *a* is the last node or the most recent node that has a subproblem size less than or equal to target subproblem size. The parent node *i* (the next node visited by the traversal module) has a subproblem size greater than the target subproblem size. So, only node *a* is selected to be processed by the CPLEX module, not node *i*. Similarly, node *b*, *c* and *d* is selected to be processed by the CPLEX module.

The next step is the solution of the Subproblem defined by the subtree rooted at the selected node. Though CPLEX can solve the subproblem optimally in a short time, a cost table with cost function values still needs to be generated because without it the dynamic program cannot resume its operation at the upper level nodes. In this respect, initially the CPLEX instance is modeled after the Covering Problem integer program (as described in 1.1) defined by the subproblem at the selected node. Then for every cost function, variables and constraints are deleted from the CPLEX instance for the set of clients that are already covered by the facilities in the cost function. CPLEX then solves the downsized integer program. The cost function value will include the opening (or penalty) costs of the facilities present in the cost function and the cost value produced by CPLEX which denotes the subproblem solution value at that node. Thus at the end the selected node will have a cost table with cost function values that are produced by CPLEX.

This is a simple enough algorithm, but in practice we had the most success with this algorithm. The experiment results and evaluation are described in detail in chapter 4.

3.3.2 A Parallel Algorithm for Solving Covering Problem

One of the unique properties of Tree Decomposition is its ability to divide a problem into smaller independent subproblems. At each Tree Decomposition node an independent subproblem can be defined by the set of vertices in the subtree rooted at that node. The simplest parallelism that can be introduced in this respect is to solve each of these subproblems on a separate machine and then consolidate the result at the root node to get the solution. As the problems are independent, the allocated machines does not need to interact with each other. They solve the assigned problem and report the solution back to the source. Our algorithm uses the same idea. The execution of our algorithm depends heavily on the *CONDOR GRID* installed in our CS network which ensures a high performance in terms of job scheduling, efficient utilization of available resources.

Condor is a open source high-throughput software framework for distributed parallelization of computationally intensive task. As an HTC (High-throughput computing) system Condor is very robust and reliable when running a task using many computing resources. This high throughput computing also ensures an efficient execution of a task over a long time with relatively small overhead. Condor accepts an implementation of an algorithm (a program) as a "*job*" and assigns this job to a remote machine for execution from its pool of available machines. It allows a user to submit multiple jobs at the same time. Condor offers a huge advantage by efficiently using the idle machines in a network. Condor handles the submission and scheduling of jobs, connection to remote machines, remote system calls and reporting the output back to source machine where the job was submitted. Our algorithm utilizes these services of Condor to parallelize the solution of subproblems.

This algorithm follows from the Hybrid algorithm discussed earlier. In Hybrid algorithm, we solved a chunk of subproblems using CPLEX then the rest of the Tree Decomposition nodes are processed

by the Dynamic program. We will follow the same idea but instead of solving the subproblems with CPLEX in one machine, each of the subproblems will be solved in a separate machine. The output results are reported back to the source and the source machine will then start the dynamic program on the rest of the Tree Decomposition as it has the subproblems solutions available from the remote machines. So, basically there are three steps for this algorithm-

- Subproblem writing
- Subproblem Solving
- Accumulation of the solutions

In the subproblem writing step, the subproblems that are to be solved by CPLEX are written in text files. The next step, the subproblem solving step submits each subproblem file as a job to the Condor Grid. The Condor then assigns a suitable machine from its pool of available machines to solve the subproblem. The remote machines solve the problem and write the solution information into a file. After the source machine has all the solution files, the Accumulation of the solutions step begins where the algorithm resumes the dynamic program for the Tree Decomposition nodes for whom the subproblem sizes are greater than the target subproblem size (as described in 3.3.1). The implementation details are discussed in the implementation section of this chapter.

When compared to the Hybrid Algorithm, the running time for this technique is almost similar to that of the Hybrid. This is because CPLEX is very fast to solve Covering problem even on a large instance on a single machine. Though we hoped that dividing the workload among several machines would outweigh solving the Covering problem by CPLEX on a single machine however in reality the performance improvement was negligible overall. For this reason we used the Hybrid Algorithm for further experimentation. But we conjecture that this parallel algorithm will be effective for problems with larger integrality gap that are difficult to solve by CPLEX.

3.4 Implementation

As mentioned earlier in chapter 2 , for implementation we used Python 2.7 as a programming language. In the following sections, we will discuss the major data structures of the dynamic program and then we will briefly describe the steps our program follows to compute the optimal solution. In the later sections we will discuss several techniques that are used to accelerate the program.

3.4.1 *Dynamic Program*

Data Structures In order to represent each node in the tree decomposition, we wrote a class *Node_with_table* with different data attributes. As every node is associated with a cost table, we simply added the cost table as a data attribute in the class. Each cost table is a dictionary, a hash table type data structure of Python. For a tree decomposition node i and its vertex set X_i , this dictionary contains the entries where the key is the facility allocation f and the value is the cost function $\Phi(X_i, f)$. We used a two dimensional list, an array type data structure of Python, to represent the pair shortest path weight matrix generated by the Floyd Warshall algorithm.

Brief Description First, our dynamic program traverses the tree bottom up recursively. Starting from the root node, the recursive function traverses the child list and appends the child nodes into a stack. Then, the function keeps calling itself with the top node of the stack as the root for the next iteration. If it reached a target node (leaf node, or a node whose children has already been traversed), it deletes that node from the stack and the function returns. Whenever each of the recursive call is terminated, that means either a leaf node or a node (top node of the stack) whose children has already been traversed is reached at that point. So, through the recursive call terminations, the module keeps moving upward through the tree decomposition towards the root.

Now, before the function return statement, the program invokes another module that generates one or more nice tree decomposition nodes till it reaches up to the parent node. If the target node i is a

original tree decomposition leaf node with the cardinality of the vertex set greater than 1, then this module generates a nice tree decomposition leaf node j with a single vertex chosen randomly from the original leaf node's vertex set. Then, it treats the original tree decomposition leaf node just as a regular introduce node where the introduce vertex set is $= \{X_i \setminus X_j\}$, where i is the original tree decomposition leaf node and j is the newly generated nice tree decomposition leaf node.

If the target node i is a node whose child j has been traversed, then the module generates a nice tree decomposition forget node where the forgotten vertices are $= \{X_j \setminus X_i\}$. Then the module treats the already present node i as an introduce node, where the introduce vertex set is $= \{X_i \setminus X_j\}$. Whenever the module generates a nice tree decomposition nodes (or treat like one), invokes the module for processing that specific node. For example, if the node is a introduce node, the program will invoke the *process_introduce_node* module. Then the node processing module invokes the permutation module to enumerate all possible facility allocation functions for the client set in the node. Then, for each facility allocation function, it computes the cost value according to the cost function definitions of that node. After computing the cost value, it inserts the cost entry in the cost table, where it stores the facility allocation function as a key and the cost value as value in the dictionary.

As the traversal module is working its way upwards and reaches the root, the root node's cost table then has all possible solutions for the Covering problem. We take the solution with minimum cost value. The solution is partial in the sense that only the value of the optimal objective is known, and the facility allocation function for the vertices of the root node is known. However, the information about facilities covering the other vertices of the graph needs to be recovered from the cost functions at tree decomposition nodes below the root.

In this respect, the program keeps another table called *cost_backtrack_table*(a dictionary) for each node. While computing each possible cost function for a client set in a node, the program accesses the child node's cost function for that specific facility allocation. This *cost_backtrack_table* stores the child node's cost function keyed by the current node's cost function for each possible facility

allocation at a node. We developed a solution backtrack module where given an optimal solution at the root (contains cost value and cost function for the root node), it recursively accesses the node's *cost_backtrack_table*, uses the solution cost function as the key and finds the child node's cost function which was used to compute current node's cost function. The module keeps adding the facility allocation found from the child node's cost function in a list. It keeps calling itself until it reaches a leaf node. At the end it returns with the opened facility list it has discovered from the nodes below the root.

But this approach to recover the full solution proved really costly as each *cost_backtrack_table* occupies a considerable amount of memory which leads to a memory exhaustion. To counter this problem we found a simple yet efficient way to discover the solution. At each cost table against a cost function the program will store a pair of values where the first value is the cost function value and second value is a list of integer which denotes the indices (of the vertex set of the input graph) of all opened facilities for that cost function. At a leaf node this set of opened facilities will contain only one vertex (leaf node vertex). At a parent node, the set of opened facilities indices will contain the set union of the facilities that are opened by the cost function and set of opened facilities from the child node for that respective cost function. In this way at the root the optimal solution cost tuple will contain all the facilities that are opened for this solution branch. We just have to retrieve the facilities from the vertex set by the integer indices.

3.4.2 Pruning Heuristic Module

Given a client set and its assigned permuted facility set, for each client this module checks the distances between the client and each facility in the permuted facility set. If it finds a facility that is closer to the client than the already assigned one, then the module discards the current facility allocation function, and as a result, no cost function will be computed for it.

3.4.3 Branch and Bound Technique

There is a preprocessing step for executing the dynamic programming algorithm equipped with the Branch and Bound Technique. We need to compute an upper bound (feasible solution) of the entire problem defined by the input graph and a lower bound for every cost function generated at each node. We used the CPLEX module to compute both bounds. Though CPLEX is very fast to compute the bounds, given a large graph instance the cumulative time to compute these bounds is quite high. So, for a faster execution of our program, we precomputed these bounds (solving relaxation of subproblems) for each node and wrote them into a file using a sorted list. Whenever the program is processing an introduce node or a join node (because only for these nodes we include the pruning by Branch and Bound, for leaf and forget nodes this technique does not apply) rather than computing the relaxation of the subproblem defined by the subtree in between the given node and the root, it reads the corresponding solution value from the file. It resumes normal execution after that.

In case of an introduce or a join node, after computing the lower bound for the cost function by adding the cost function objective value with the retrieved subproblem (defined by the Tree Decomposition without the subtree rooted at the given node) solution value, the program checks whether the lower bound is greater than the upper bound (feasible solution). If greater then the cost function is discarded or pruned else the program inserts the cost function into the cost table with its solution value.

3.4.4 Hybrid Algorithm

To implement the Hybrid Algorithm we developed two new modules-

- *modified traversal module*
- *a subproblem solver module with CPLEX*

We introduced a new parameter called *target subproblem size*. This parameter is used for the selection of nodes for which the subproblems defined by their subtree will be solved by CPLEX. If the

subproblem size of a node is less than or equal to the target subproblem size, then the subproblem will be solved by CPLEX, else it will be solved by the dynamic program.

We modified the traversal module described in 3.4.1 to support the algorithm requirement. As it traverses the tree recursively using a bottom up approach, it also keeps track of the size of the subtree at each node. Because this is a bottom up traversal, if the first node that has a subtree (subproblem) whose size is greater than the target subproblem size (described in 3.2.3), then it's child must be the last node whose subtree (subproblem) size is less than or equal to target subproblem size. To solve the subproblem defined by the subtree rooted at this selected node, it calls a subproblem solver module with CPLEX. For nodes that has the subtree size is greater than the target subtree size, the program resumes the dynamic programming operation as discussed in 3.4.1

We used the CPLEX 12.1 PYTHON API to implement the subproblem solver module. Given the subproblem definition, this module fills up a CPLEX instance with necessary variable and constraints to imitate the integer program for Covering problem restricted to this subproblem. For each cost function permutation, a set of clients that are covered by the facilities opened by the cost function is computed. The variables and constraints corresponding to those covered clients are deleted from the CPLEX model. Then this reduced model is solved optimally by CPLEX. The cost function value contains this curtailed subproblem solution value and the facility opening cost (or penalty) from the facilities present in the cost function. At the end of this module, the cost table is returned.

3.4.5 Parallel Algorithm

To implement the parallel programming algorithm, we developed three separate programs-

- *Subproblem Writer*
- *Subproblem Solver*
- *Accumulator*

The program structure for the Subproblem Writer is similar to that of Hybrid Algorithm program. It traverses the tree using the modified traversal algorithm described earlier. It uses the *target subproblem size* parameter the same way Hybrid algorithm does to select the subproblems to be solved by CPLEX module. Once the subproblems are selected, it writes their definition in text files. Then for each subproblem files it generates a *MakeFlow* rule which is then added into a Makeflow script. MakeFlow is a workflow engine for executing large complex workflows on clusters, clouds and grids. It accepts a specification of a large amount of work to be performed, and can be made to submit these jobs to some already installed grid system. As we have a CONDOR GRID installed in our system, the MakeFlow tool is used to generate specifications for a series of jobs and the submission of the Makeflow script (`script_name.makeflow`) to Condor. Each MakeFlow rule specifies a *target file*, a set of *source files* needed to create it and a *command* that generates the target file from the source files. In our case, in each rule, the target file is a cost table associated with the current subproblem, the set of source files are all the external python modules imported to run the program and the command is python runtime command which instructs the python interpreter to execute the Subproblem Solver program with the given subproblem file name. At the end, this program will generate a MakeFlow script called "Coverage.makeflow" which will have a rule for each subproblem that are to be solved by CPLEX.

When this Coverage.makeflow script is submitted to Condor grid, for each rule the program Subproblem Solver is called with a subproblem file name. This program reads the subproblem definitions from the subproblem file (given the subproblem file name) and calls the subproblem solver module with CPLEX (as described in 3.4.4) to solve the subproblem. This program returns the cost table containing the cost function values associated with this subproblem. Once the cost table is returned by this program, Condor automatically returns this cost table back to the source machine, where it is stored in a text file.

The *Accumulator* program is activated once all the necessary subproblem cost tables are returned by Condor. Because once the cost tables are available, this program can start the dynamic program

for those nodes that has subtree (subproblem) size is greater than the target subproblem size. It then follows the dynamic program and finds the solution from the root.

In practice the brute force approach is slow even for small graphs. During Implementation we developed some tricks and techniques to speed up the algorithm. In the following sections, we will discuss these techniques.

3.4.6 Cost Table Reduction Technique

The brute force approach has proven to be very expensive as it has a very high storage space (memory) requirements. This is mainly because of the exponential size of the cost tables associated with each tree decomposition node. Whilst the pruning heuristic reduces a significant number of entries from the tables, for larger graphs the memory overhead for these cost tables are still high. In this respect we developed a technique which requires only a few number of cost tables for the entire dynamic program.

As mentioned earlier in Section 3.4.1, the bottom up traversal module keeps traversing a node's children recursively until it reaches a leaf node or a node whose children has already been visited. Then it moves upward through recursive call terminations. So depending on the child list of a node, the module moves from branch to branch of the tree decomposition. In this technique, rather than keeping a separate cost table for each node, we keep a pair of cost tables (*parent_node_cost_table* and *child_node_cost_table*) for a child node to parent node transition. As described in Section 3.4.1, there can be more than one nice tree decomposition nodes in a child to parent transition. So, we reuse this pair of cost table for each child-parent pair. Once a node is being processed, initially it's cost function entries are store in the *parent_node_cost_table*. After the node is processed, it empties the cost table *parent_node_cost_table* after it has been copied into *child_node_cost_table* as now the processed node becomes a child while it's parent node is being processed. At the end of the transition (for the final child-parent pair), the module keeps the *parent_node's_cost_table* into

a *cost_tables* dictionary. It empties the *child_node's_cost_table* as it is no longer required. Then the traversal module moves onto a new node. If the new node is a leaf node, then the program executes the steps described earlier for the transition from the leaf node to introduce node. After the transition is finished, it keeps the cost table of the parent node (in this case the introduce node) into the *cost_tables* dictionary. If the node is any other node except a leaf node, then the node's child has already been processed and its cost table must be stored in the *cost_tables* dictionary. It copies that specific cost table into the *child_node's_cost_table* and then deletes it from the *cost_tables* dictionary. At this point the *parent_node's_cost_table* is blank. The module repeats the same steps including reusing these two cost tables for this new transition.

3.4.7 Bounding the Assignment Function

As we have described in section 3.2.2, for a node i , the modified assignment function $f, f : X_i \rightarrow CN(i)$, where $CN(i)$ is the covering neighborhood of node i , now enumerates all vertices of the set $CN(i)$, thus reducing a great number of redundant cost functions. Even then, it is possible to have many cost functions that are generated through the process described in 3.2.2 only to be discarded by the pruning heuristic. In this technique, we will discard some of those cost functions before they are generated by the assignment function f .

This technique follows from the Pruning Heuristic described in Section 3.2.1 which checks the distances between the clients and the facilities (assigned by the f function) and discards the facility configuration if the facility assigned to a client is not closest to it. Using the triangle inequality we can extend this distance checking technique to assign an upper and lower bound on the assignment function f . This way, vertices that are outside the upper and lower bound will not be visited while processing an introduce node.

In the nice tree decomposition, the client set at the child node is a subset of the parent node. As we

are using a bottom up dynamic program, when the program processes the parent node, the subset which is equal to the child node's client set is already assigned some facilities whose cost function entries can be found on the child node's cost table. Currently while generating the facility configurations (by the assignment function f), the program generates all possible configurations and then applies the Pruning Heuristic to get rid of the invalid configurations. In this technique we will use the already allocated clients to apply bounds on the non-allocated clients.

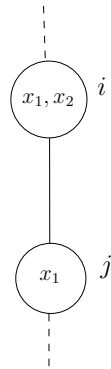

Figure 3.5: Parent and child with common elements

We will describe the bounding technique in the context of figure 3.6 where a parent node and a child node is shown, where the parent node i is an introduce node and the child node j is a leaf node. The client set of node j is $X_j = \{x_1\}$ and the client set of node i is $X_i = \{x_1, x_2\}$. So the common element between node i and node j is x_1 . The dynamic program will process the leaf node before the parent node and will assign a facility for every valid permutations. Let $f(x_1)$ represent the facility assigned to x_1 .

While processing the parent node i , we will use the allocation of client x_1 to apply a upper and lower bound on the assignment function f for client x_2 . In the below figure, a symbolic representation of the distances between clients $\{x_1, x_2\}$ and their assigned facilities $\{f(x_1), f(x_2)\}$. here $f(x_2)$ represents the set of potential facilities for client x_2 .

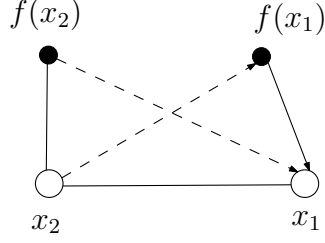

Figure 3.6: distances representation between clients and facilities

The client x_1 is already served by $f(x_1)$. The upper bound that will be applied to $f(x_2)$ follows directly from the Pruning technique. The distance $d(x_2, f(x_2))$ must be smaller than the distance $d(x_2, f(x_1))$. Otherwise x_2 can be served by $f(x_1)$. So the **upper bound** on $f(x_2)$ can be defined as-

$$d(x_2, f(x_2)) \leq d(x_2, f(x_1))$$

Now, using the triangle inequality , we can derive the following relation from the triangle formed by x_2, x_1 and $f(x_2)$ from the figure 3.6-

$$d(x_2, f(x_2)) + d(x_2, x_1) \geq d(f(x_2), x_1)$$

Again, in order to become a valid configuration the distance $d(f(x_2), x_1)$ must be greater than the distance $d(x_1, f(x_1))$. So, we can rewrite the previous relation and define the **lower bound** on $f(x_2)$ as below -

$$\begin{aligned} d(x_2, f(x_2)) + d(x_2, x_1) &\geq d(x_1, f(x_1)), \\ d(x_2, f(x_2)) &\geq d(x_1, f(x_1)) - d(x_2, x_1) \end{aligned}$$

So facility assignment function $f(x_2)$ will permute from the set of vertices for which the distance between them and the client x_2 falls between the upper and lower bound. The rest of the vertices will be discarded.

These bounds can be extended for client sets with any number of clients. For example, for any node k , if the client set is $X_k = \{x_1, x_2, x_3\}$, the fixed facility allocation for x_2 and x_3 is $f(x_2)$ and $f(x_3)$, then the **upper bound** on $f(x_1)$, the potential facility for x_1 is -

$$d(x_1, f(x_1)) \leq \min_{e>1} d(x_1, f(x_e))$$

Similarly using the same triangle inequality technique described above the **lower bound** on $f(x_1)$ is,

$$d(x_1, f(x_1)) \geq \max_{e>1} \{d(x_e, f(x_e)) - d(x_e, x_1)\}$$

Earlier, for a tree node i where X_i contains p number of vertices, the program used to generate n^p number of facility configurations where n denotes the number of vertices in the graph. Now with this bounding technique the program is generating l^p entries for some number $l \leq n$, which depends on the upper and lower bound at that node. The program still uses the pruning technique to validate the permutations, as both these bounds are loose bounds. In practice, the combination of these techniques produces a much better result than before.

3.4.8 Balancing the Height of the Tree Decomposition

The Tree Decompositions produced by the Tree Decomposition heuristics are not height balanced. As a result sometimes the root of the Tree Decomposition can be located in the longest branch of the Tree Decomposition. As we described in 3.4.3, in a branch the number of cost tables is depended on the height of that branch from leaf to root. The longer is the height, the more number of cost tables are kept in the memory. As there can be numerous branches spawned from the root node, we can't chose an arbitrary root because it might reduce the length or height of a particular branch but might increase the height of some other branch spawned from it.

One way to find such a root is to find the center of a Tree Decomposition and set it as root. For a

center a of a Tree Decomposition, the following relation holds-

$$\min_{x \in I} \max_{y \in I} d(x, y)$$

Where $d(x, y)$ is shortest distance between x and y , and I is the node set of the Tree Decomposition. There is a simple algorithm for finding the center of a tree proposed by Murdasov [23]. We followed the same idea in case of a Tree Decomposition. The steps of our algorithm is given below-

- Select an arbitrary leaf node i from the Tree Decomposition.
- Find the most remote node from i using a depth first search. Suppose the remote node is j .
- Find a node p that is furthest from j using a depth first search (this operation will yield the diameter of the Tree Decomposition).
- The node t for which the equality

$$d(j, t) = d(t, p)$$

holds is the center of the Tree Decomposition. Make this node t as the new root.

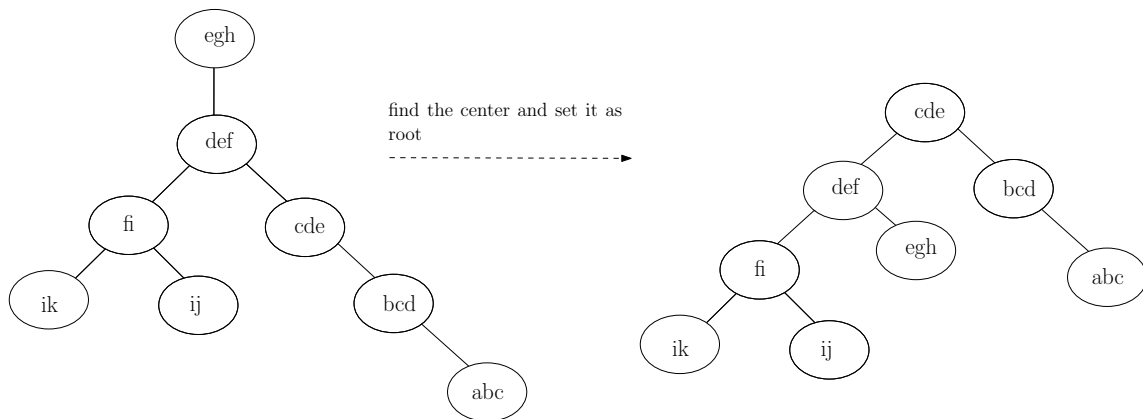

Figure 3.7: Balancing the Height of a Tree Decomposition

A Tree Decomposition of a graph drawn in Figure 2.1 is shown in the left hand side. In the right hand side, another Tree Decomposition of the same graph is shown with its center as the new root.

In practice this technique reduced the number of cost tables that are kept in the memory at a given time.

3.4.9 Using a Modified Dijkstra's algorithm to Compute Shortest Path

As discussed in 3.4.1, the shortest path matrix (a two dimensional list) is computed with the Floyd-Warshall algorithm which has a complexity $O(n^3)$. For large graph instances, the computation for the shortest path matrix using this algorithm is very costly in terms of running time. We decided to run modified version of dijkstra's algorithm (complexity $O(n^2)$) for every vertex of the graph to fill the shortest path matrix.

The modification follows from the improvement discussed in 3.2.2 where the set of potential facilities for a client is restricted to the covering neighborhood of that client. We stopped the execution of the dijkstra's algorithm when the current distance estimate between the source vertex and any other vertex is greater than the client radius. So, for a client, only the shortest path between the facilities inside the client radius and the client are computed through this modification. Also, to make it faster we used a min heap as a data structure for the queue in the algorithm.

Using this modified dijkstra's algorithm helped us as it reduced the total running time greatly compared to the Floyd-Warshall algorithm. It does not have any effect on the dynamic program as the dynamic program run time is computed by subtracting the total running time from the shortest path running time. But it made the execution of the program really fast.

In the next Chapter we will present the empirical data of several experiments for Tree Decomposition computation and for solving the Covering problem using our algorithms. We will analyze the data and will discuss the findings of our research.

Chapter 4

Experiments

In this chapter we present the experimental results of the algorithms to solve the standard Covering problem. In this research, we used only randomly generated graphs for our experiments because it is expensive to gather and interpret the wireless network data and generate graph representation from them. We plan to use the real time wireless data for experiments in future. In section 4.1, we discuss the experiment results of the construction of Tree Decomposition by the heuristics described in Chapter 2. In the next section (4.2), we will present the experiment results of three algorithms which solves the standard Covering problem. In section 4.3, we analyze the results and find inference from the evaluation.

All the algorithms are implemented using Python 2.7. We used Python because it is easy to program and very quick to implement any algorithm in it. All the experiments presented in this chapter were conducted on 3.00 GHz Pentium(R) 4, 64 bit processor with 1 GB RAM in the Linux CentOS environment.

4.1 Tree Decomposition Experiments

For Tree Decomposition experiments, we will use the following three algorithms that are described in Chapter 2 -

- Minimum Separator Vertex Set Heuristic (MSVS)
- Clique Tree Heuristic (CLQT)
- Random Separator Vertex Set Heuristic (RSVS)

4.1.1 Data Sets

For these experiments, we used unit disk graphs to randomly generate dense graphs and series parallel graphs to randomly generate sparse graphs. The procedure for generating these graphs are discussed below.

Unit Disk Graph In geometric graph theory, a unit disk graph is an intersection graph of a set of unit circles in the Euclidean plane; each vertex corresponds to a circle, and an edge is placed between two vertices when the corresponding circles intersect [6]. The steps for generating random unit disk graph is given below-

- We specified the total number of vertices ($|V|$) of the graph.
- For each vertex we randomly generate a (x,y) co-ordinate and assign it to that vertex.
- For every pair of vertex we compute the Euclidean distance d between them, and then check whether $d < T$, where T is the threshold value that we defined earlier. If $d < T$, then we insert an edge between the vertices if not then we move to the next pair of vertices.

Series Parallel Graph In graph theory, a *series parallel graph* is a graph of two distinguished vertices called source (s) and sink (t) which denotes two terminals (end points) of the graph and formed recursively using two composition(series composition or parallel composition) operation. A two terminal series parallel graph G with terminals s and t can be produced by a sequence of the following operations:

1. Create a new graph, consisting of a single edge directed from s to t .
2. Given two two-terminal series parallel graphs X and Y , with terminals s_X, t_X, s_Y , and t_Y , form a new graph $G = P(X, Y)$ by identifying $s = s_X = s_Y$ and $t = t_X = t_Y$. This is known as the *parallel composition* of X and Y .
3. Given two two-terminal series parallel graphs X and Y , with terminals s_X, t_X, s_Y , and t_Y , form a new graph $G = S(X, Y)$ by identifying $s = s_X, t_X = s_Y$, and $t = t_Y$. This is known as the *series*

composition of X and Y .

This definition and the steps of composition follows from the work of David Eppstein [8] in his study of recognition of series parallel graphs.

Series-parallel graphs are a useful class of graphs. They are fairly simple to generate and allows easy proofs for many results. In particular, series-parallel graphs are a fertile testing ground for various conjectures. Also one of the main reason to use series parallel graphs in our experiments is that the treewidth for this class of graph is no more than 2, which proved to be an excellent test ground for our algorithms. Because it is expensive to run algorithms on a tree decomposition of higher treewidth.

Below we discuss the steps of generating random series-parallel graphs:

- We generate a series of random even number upto a given limit.
- For each even number e we generate a two-terminal series-parallel subgraph where the number e will define the number of nodes of the subgraph. In order to generate it, we will create a graph with two vertices and only one edge connecting them. We recursively add this graph to itself using either a series connection or a parallel connection until the the number e is reached. We do this using a coin toss procedure. We generate a random number r , between 0 and 1. If $r > 0.5$, then we add the edge using series connection and if $r \leq 0.5$, we add the edge in parallel connection.
- After all the series-parallel subgraph/components are generated, we connect them either through series connection or parallel connection using the same coin toss procedure described earlier.

4.1.2 Tree Decomposition Experiment Results

In this section we present the experimental data of computing Tree Decomposition by the three algorithm mentioned above. Table 4.1 contains the empirical data of experiments done on the randomly generated dense graphs (unit disk graphs) and Table 4.2 contains data of experiments

done on randomly generated sparse graphs (series parallel graphs). The first and second column of the tables denotes the number of nodes and edges of the graph. The third, fourth and fifth column represents the average running time (in sec) of the algorithms Clique Tree Heuristic(CLQT), Minimum Separator Vertex Set Heuristic (MSVS), Random Separator Vertex Set Heuristic (RSVS). The sixth, seventh and eighth column of the tables represent the treewidth data of algorithm CLQT, MSVS and RSVS.

Table 4.1: Tree Decomposition Experiments on Random Dense Graphs

Vertices	Edges	Runtime (Sec)			TreeWidth		
		CLQT	MSVS	RSVS	CLQT	MSVS	RSVS
50	396	0.085	32.34	5.56	10	10	10
75	836	0.272	546.65	75.66	15	14	15
100	1450	0.61	2519.72	329.82	19	18	18
150	3562	2.66	27826	3545	41	42	42
200	2416	6.44	35973	7026	25	23	23
250	2770	7.98	88416	10900	30	24	24

Table 4.2: Tree Decomposition Experiments on Random Sparse Graphs

Vertices	Edges	Runtime (Sec)			TreeWidth		
		CLQT	MSVS	RSVS	CLQT	MSVS	RSVS
171	192	0.288	2081.24	155.823	2	2	3
264	303	1.018	4523.07	254.51	2	2	3
359	418	2.569	21134.39	703.47	4	2	3
435	495	4.491	61220.85	910.44	3	2	3
532	614	8.45	116251.83	7437.11	4	2	3
612	699	12.77	47030.16	1088.74	2	2	3

It is evident after observing the data in the above tables that the Clique Tree Heuristic(CLQT) is significantly faster than the other two algorithms. The Minimum Separator Vertex set heuristic(MSVS) has the largest running time. This is because finding a minimum separator is really expensive. The Random Separator Heuristic(RSVS) fares better in terms of running time than MSVS. Because In RSVS, instead of finding separator for every pair of vertices, we randomly select a few pairs of vertices and then find the minimal separator for each of those selected pairs.

Though the CLQT has the least running time, the quality of the Tree Decomposition(Treewidth) is not minimal all the time. MSVS algorithm has the ability to produce the best (among these three algorithm) quality Tree Decomposition almost at every run. RSVS algorithm is produces a decent quality Tree Decomposition, some times even better than CLQT algorithm. After evaluating these results, we decided to chose CLQT for our primary algorithm to generate Tree Decomposition for our dynamic program. Though sometimes the Treewidth is not minimal in the Tree Decomposition produced by CLQT, but after a few runs of CLQT on the same graph, eventually we were able to get the desired Tree Decomposition with the desired Treewidth (in case of series parallel graphs, the desired treewidth is 2).

4.2 Covering Problem Algorithm Experiments

We followed the trial and error approach while developing the dynamic program algorithm to solve the Covering Problem. At the initial phase of the program (where at each node the program was generating n^{k+1} cost functions) even for a 200 node graph, the program took more than a week to solve the problem. This is mainly because of the generation of huge amount of cost functions that filled up the memory very quickly. So we started developing techniques that reduced the number of cost functions. These includes the pruning heuristic, bounding the assignment functions, branch and bound technique and several implementation tricks as discussed in Chapter 3. We employed all of them into a single program and then began experiment with larger graphs. This time it solved the problem much quicker than the initial program. We used CPLEX to solve the problem on the same graphs to ensure the correctness of our program. But we found out that CPLEX solves this problem on the same graphs very quickly. At that point we decided to incorporate the power of CPLEX in our program and developed a *Hybrid* algorithm which employs dynamic program as well as CPLEX. With CPLEX we solved subproblems defined by the bottom part of the Tree Decomposition. We defined the size of the subproblems that will be solved by CPLEX, the rest of the Tree nodes are solved by the Dynamic program. We developed this Hybrid algorithm with the intuition that, once

CPLEX solves the subproblems defined by the bottom parts (larger parts) of the Tree Decomposition, then for the rest of the tree nodes the dynamic Program will outweigh CPLEX which will result a total runtime that will beat CPLEX.

For our experiments, We ran the following three algorithms on the random graphs-

- CPLEX
- Hybrid Program (Hybrid)
- Hybrid Program with Branch and Bound (Hybrid_with_bb)

The Hybrid Program (Hybrid) and Hybrid Program with Branch and Bound (Hybrid_with_bb) are two versions of the same program. The first one (Hybrid) contains all the techniques and the implementation tricks discussed in Chapter 3 except the Branch and Bound technique. The later one (Hybrid_with_bb) contains the all the techniques including the Branch and Bound. The reason we developed these two versions of the program is to show the performance difference between the program without branch and bound and the program that employed the branch and bound. We used CPLEX to solve the same graphs to ensure correctness and also for the runtime comparison among these three algorithms.

4.2.1 Data Sets

In our experiments, we decided to use the randomly generated series-parallel graphs (as described in section 4.1.1). It is expensive in terms of running time to run our algorithm on a Tree Decomposition with high Treewidth. As a series-parallel graph can have treewidth at most two, it ensures a quick solution time by our algorithms. Also it loosely mimics (by sparsity and connectivity) a wireless network environment.

Though our initial target was to evaluate the performance of our algorithms on sparse graphs (so that they can be employed later on wireless networks to solve the covering problem), we tried to run

our algorithms on dense graphs as well. But our algorithms are not feasible for Tree Decomposition with high treewidth. So for this thesis we kept our focus on running algorithms on series-parallel graphs.

4.2.2 *Experiment Results*

In the following, we present the empirical data for four Covering Problem instance on different series-parallel graphs. We designed four Covering problem instances for our experiment. The parameters for the instances of the Covering Problem is given below-

- 1st Instance : *client radius* = 10, *facility opening cost* = 15 and *penalty* = 20.
- 2nd Instance : *client radius* = 20, *facility opening cost* = 25 and *penalty* = 20.
- 3rd Instance : *client radius* = 30, *facility opening cost* = 13 and *penalty* = 22.
- 4th Instance : *client radius* = 40, *facility opening cost* = 10 and *penalty* = 17.

In these instances the client radius sets up a covering range for the clients. This covering range determines an average size of the neighborhood set of a vertex. We started with a small radius in the first instance then gradually increased it in the other instances to check the performance of our algorithms with a large neighborhood set. As for the different facility opening cost and penalty, we at first ran experiments with several random opening and penalty cost on smaller graphs. From those experiments we chose four sets of opening and penalty costs to be included in our instances.

Table 4.3 contains runtime data for solving the 1st instance described above by CPLEX, Hybrid and Hybrid_with_bb on six series-parallel graphs of treewidth 2. The first four columns contains the graph data (number of vertices $|V|$ and number of edges $|E|$) and Tree Decomposition data (number of Tree Decomposition Nodes $|N|$ and number of Tree Decomposition Edges $|E|$). The fifth column *Runtime for CPLEX(s)* includes the average runtime (in seconds) data for CPLEX on each graphs. This runtime data is computed after subtracting the runtime to compute the shortest path

Table 4.3: Runtime Comparison among CPLEX, Hybrid Program and Hybrid with BB(Branch and Bound) for a Covering problem Instance where radius = 10, facility opening cost = 15 and penalty = 20

Graph		Tree D		Runtime for CPLEX(s)	Subprob Size	Num of Dyn node	Runtime for Hybrid(s)	Runtime for Hybrid with BB(s)
V	E	NI	EI					
516	582	514	513	0.421	75	70	9.986	8.983
					150	33	4.90	4.55
					200	13	2.651	2.531
					250	4	1.74	1.679
					300	1	1.006	0.979
1149	1323	1146	1145	0.864	200	226	36.794	32.449
					400	104	19.68	17.44
					600	3	3.042	3.183
					700	1	2.377	2.299
					500	206	46.18	37.5
2004	2283	2002	2001	1.901	800	108	26.53	21.915
					1000	52	14.451	11.852
					1200	4	3.357	2.984
					1500	1	2.655	2.637
					1000	397	129.44	99.904
3330	3810	3328	3327	4.657	1200	281	92.741	72.192
					1500	112	40.605	32.373
					2000	1	4.796	4.561
					2000	376	241.095	183.878
5254	6008	5252	5251	14.138	2500	76	65.44	52.513
					2800	1	14.16	12.854
					3000	1	14.38	12.878
					2500	264	387.061	316.055
8752	10004	8749	8748	38.657	3500	199	320.551	272.002
					5000	199	322.156	271.796
					6500	1	35.192	35.995
					6500	1	35.192	35.995

matrix from the total running time. The sixth column *Subproblem Size* contains the sizes of various subproblems. Each subproblem size indicates a number which defines the size of the subproblems that are to be solved by CPLEX in the Hybrid and Hybrid_with_bb algorithm. For each graphs we experimented with different sizes. The seventh column *Num of Dyn Node* contains the data of number of Tree Decomposition nodes processed by the dynamic program while running the Hybrid and Hybrid_with_bb program. The eighth and ninth column *Runtime for Hybrid(s)* and *Runtime for Hybrid_with_bb(s)* contains the average runtime(in seconds) for the algorithms Hybrid and Hybrid_with_bb. These runtimes are computed after subtracting the runtime to compute the shortest path matrix from the total running time. Table 4.5, 4.7, 4.9 contains similar data for 2nd, 3rd and 4th instances.

Table 4.4 contains the permutation data for solving the 1st instance of the Covering Problem for the algorithm Hybrid and Hybrid_with_bb. The first four columns contains the graph data (number of vertices $|V|$ and number of edges $|E|$) and Tree Decomposition data (number of Tree Decomposition Nodes $|N|$ and number of Tree Decomposition Edges $|E|$). The fifth column *Subproblem Size* contains the same data of the column *Subproblem Size* in Table 4.3. The sixth, seventh and eighth column are the subcolumns of *Perm data for Hybrid* gathers the permutation data for the Hybrid algorithm. The sixth column *Total Perm* indicates the total number of permutations (cost functions) generated for that specific subproblem size. The seventh column *After Pruning* denotes the number of permutations or cost functions processed by the algorithm that is the number of permutations that are not pruned. The eighth column *Total pruned perm* is the number of permutations pruned by the pruning Heuristic in the Hybrid algorithm. Columns nine to thirteen are the subcolumns of *Perm data for Hybrid_bb* which describes the permutation data for the algorithm Hybrid_with_bb. The ninth and tenth column *Total Perm* and *After pruning* contains similar data as in for the Hybrid program. The eleventh column *Pruned by Pruning Heuristic* contains the number of permutations pruned by the pruning heuristic alone. The next column *Pruned by BB* contains the number of permutations pruned by the Branch and Bound technique. The *Total pruned perm* column contains the sum of the earlier two columns. Table 4.6, 4.8 and 4.10 contains similar data for 2nd, 3rd and 4th instances of the Covering Problem.

Figure 4.1 shows the runtime comparison among CPLEX, Hybrid and Hybrid_with_bb. In case of Hybrid and Hybrid_with_bb, for each graph we took the best case running time among all the experiments for different subproblem sizes and plotted them against the number of vertices. The best case for Hybrid and Hybrid_with_bb algorithm always occurs when the dynamic program part needs to solve only one Tree Decomposition node (the root). Figure 4.3, 4.5 and 4.7 shows similar comparisons for different instances (2nd, 3rd and 4th) of the Covering problem. Each curves in these graphs are polynomial in nature as for series parallel graph the runtime $O(n^{k+2})$ becomes polynomial as k (treewidth) is no more than 2.

Figure 4.2 shows the number of permutations comparison between Hybrid and Hybrid_with_bb. For each graph we took the sum of the *Total pruned perm* for that graph and plotted these number against the number of vertices. Figure 4.4, 4.6, 4.8 shows similar permutations comparison between Hybrid and Hybrid_with_bb for other instances(2^{nd} , 3^{rd} and 4^{th}) of the Covering Problem.

In the following, the rest of the data tables along with their comparison graphs are shown sequentially. We will discuss the evaluation of these data in the analysis section.

Table 4.4: Permutations comparison between Hybrid Program and Hybrid with BB(Branch and Bound) for a Covering problem Instance where radius = 10, facility opening cost = 15 and penalty = 20

Graph		Tree D		Subprob Size	Perm data for Hybrid			Perm data for Hybrid_BB				
IVI	IEI	INI	IEI		Total perm	After pruning	Total pruned perm	Total perm	After pruning	Pruned by Pruning Heuristic	Pruned by BB	Total pruned perm
516	582	514	513	75	3774	3705	69	1688	763	41	884	925
				150	1715	1694	21	751	308	10	433	443
				200	766	753	13	352	139	8	205	213
				250	394	390	4	193	76	0	117	117
				300	99	95	4	64	20	0	44	44
1149	1323	1146	1145	200	11529	11154	375	5263	2397	158	2708	2866
				400	5976	5719	257	2794	1285	112	1397	1509
				600	442	305	137	265	139	7	119	126
				700	236	226	10	153	90	10	53	63
2004	2283	2002	2001	500	8392	8210	182	3624	1459	82	2083	2165
				800	4697	4577	120	2006	813	57	1136	1193
				1000	2456	2381	75	1039	438	28	573	601
				1200	825	200	200	0	68	21	47	47
				1500	56	56	0	29	9	0	20	20
3330	3810	3328	3327	1000	17346	16948	398	7668	3323	136	4209	4345
				1200	12012	11751	261	5313	2292	109	2912	3021
				1500	4728	4630	98	2079	917	38	1124	1162
				2000	48	48	0	25	6	0	19	19
5254	6008	5252	5251	2000	16352	15999	353	7160	2954	143	4063	4206
				2500	3528	3431	97	1509	603	37	869	906
				2800	80	80	0	37	11	0	26	26
				3000	96	96	0	37	11	0	26	26
8752	10004	8749	8748	2500	11698	11464	234	5196	2237	143	2816	2959
				3500	8540	8377	163	3790	1619	97	2074	2171
				5000	8558	8395	163	3790	1619	97	2074	2171
				6500	75	75	0	47	15	0	32	32

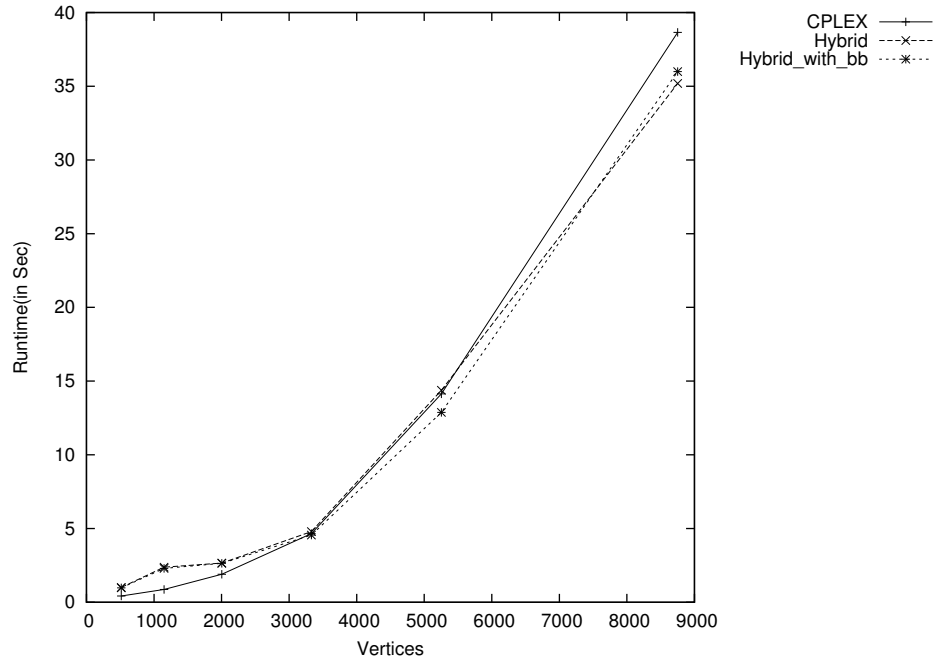

Figure 4.1: Runtime Comparison among CPLEX, Hybrid and Hybrid_with_bb for client radius = 10, facility opening cost =15 penalty =20

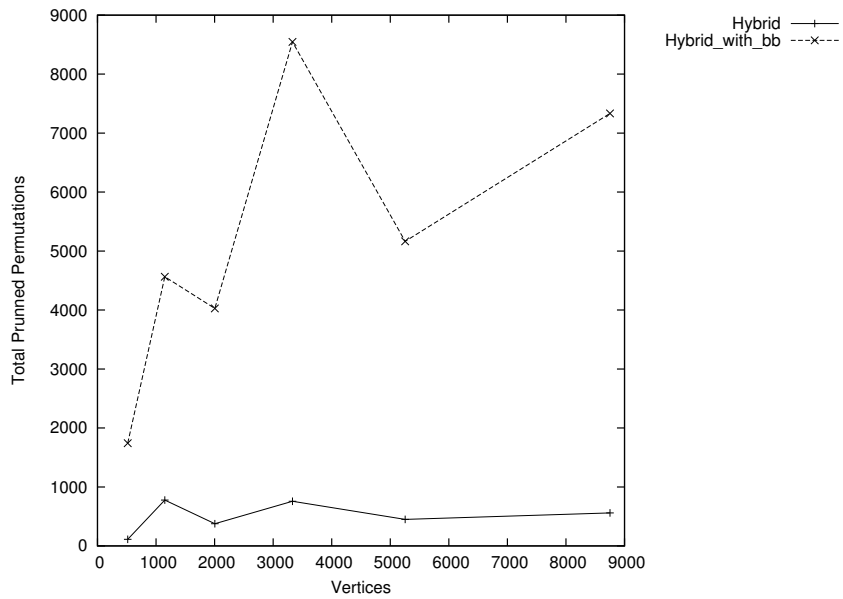

Figure 4.2: Permutation Comparison between Hybrid and Hybrid_with_bb for client radius = 10, facility opening cost =15 penalty =20

Table 4.5: Runtime Comparison among CPLEX, Hybrid Program and Hybrid with BB(Branch and Bound) for a Covering problem Instance where radius = 20, facility opening cost = 25 and penalty = 20

Graph				Tree D			Runtime for CPLEX(s)	Subprob Size	Num of Dyn node	Runtime for Hybrid(s)	Runtime for Hybrid with BB(s)
IVI	I	IEI	I	INI	I	IEI					
516		582		514		513	0.427	75	70	15.337	14.247
								150	33	7.061	6.737
								200	13	3.873	3.815
								250	4	2.85	2.689
								300	1	1.405	1.465
1149		1323		1146		1145	0.862	200	226	55.95	52.491
								400	104	53.265	48.393
								600	3	6.138	4.595
								700	1	3.854	3.102
2004		2283		2002		2001	1.932	500	206	57.785	50.731
								800	108	35.211	31.027
								1000	52	19.35	17.306
								1200	4	4.087	3.891
								1500	1	3.25	3.01
3330		3810		3328		3327	4.707	1000	397	183.601	155.026
								1200	281	131.72	110.917
								1500	112	54.611	45.2
								2000	1	5.109	5.526
5254		6008		5252		5251	12.757	2000	376	271.307	221.443
								2500	76	72.2	58.791
								2800	1	12.4	11.533
								3000	1	12.474	11.631
8752		10004		8749		8748	39.761	2500	264	492.921	416.445
								3500	199	382.823	331.911
								5000	199	380.48	343.832
								6500	1	35.92	38.6

Table 4.6: Number of Permutations comparison between Hybrid Program and Hybrid with BB(Branch and Bound) for a Covering problem Instance where radius = 20, facility opening cost = 25 and penalty = 20

Graph		Tree D		Subprob Size	Perm data for Hybrid(s)			Perm data for Hybrid_BB(s)				
IVI	IEI	INI	IEI		Total perm	After pruning	Total pruned perm	Total perm	After pruning	Pruned by Pruning Heuristic	Pruned by BB	Total pruned perm
516	582	514	513	75	6914	6529	385	4247	2944	307	996	1303
				150	2843	2742	101	1683	1103	82	498	580
				200	1287	1254	33	781	491	29	261	290
				250	650	635	15	362	204	7	151	158
				300	145	135	10	109	40	7	62	69
1149	1323	1146	1145	200	19508	18386	1122	11387	7569	840	2978	3818
				400	11377	10574	803	6756	4591	620	1545	2165
				600	1146	1060	86	473	323	52	98	150
				700	469	415	54	207	105	42	60	102
2004	2283	2002	2001	500	14196	13468	728	8177	5157	561	2459	3020
				800	8781	8246	535	5065	3254	401	1410	1811
				1000	4914	4576	338	2913	1947	265	701	966
				1200	471	437	34	275	185	13	77	90
				1500	151	133	18	98	45	12	41	53
3330	3810	3328	3327	1000	31885	29971	1914	18791	12632	1412	4747	6159
				1200	22241	20913	1328	13003	8688	971	3344	4315
				1500	8285	7752	533	4414	2746	369	1299	1668
				2000	48	48	0	80	34	12	34	46
5254	6008	5252	5251	2000	25133	23934	1199	14173	8895	887	4391	5278
				2500	5748	5371	377	2932	1698	246	988	1234
				2800	105	105	0	44	11	0	33	33
				3000	105	105	0	44	11	0	33	33
8752	10004	8749	8748	2500	20108	19255	853	11294	7451	691	3152	3843
				3500	14575	13995	580	8171	5267	474	2430	2904
				5000	14553	13973	580	8171	5267	474	2430	2904
				6500	107	107	0	86	52	0	34	34

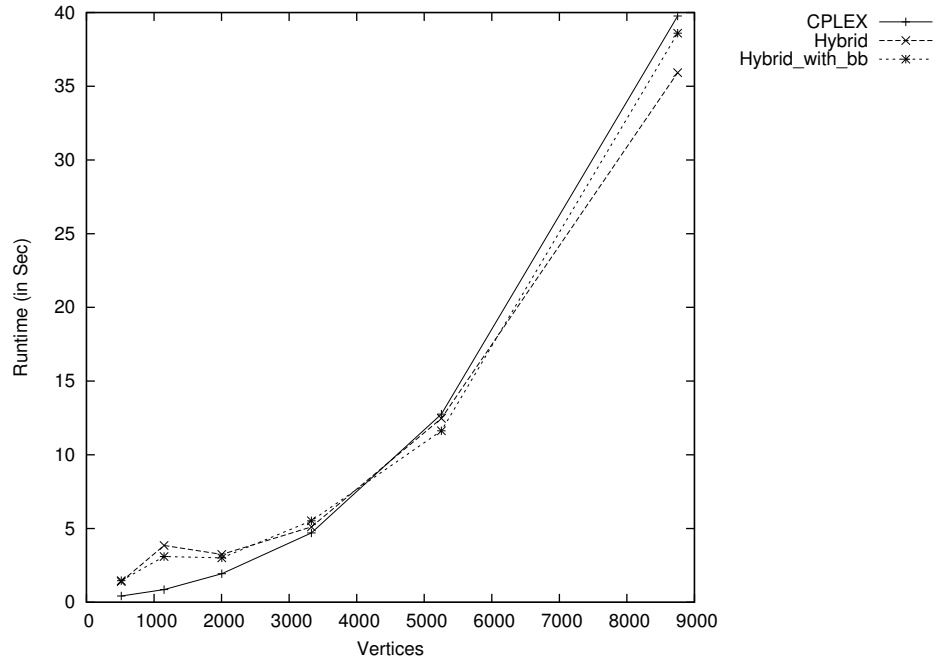

Figure 4.3: Runtime Comparison among CPLEX, Hybrid and Hybrid_with_bb for client radius = 20, facility opening cost =25 penalty =20

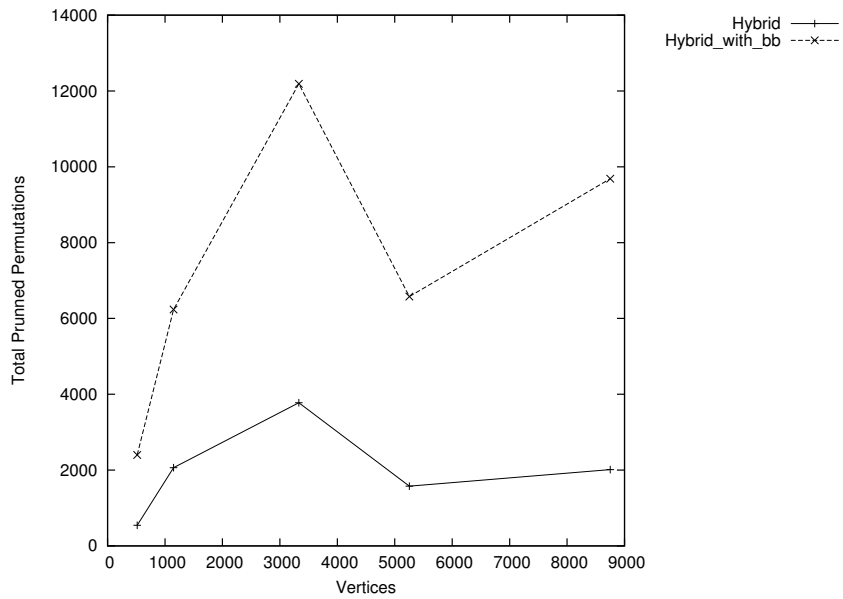

Figure 4.4: Permutation Comparison between Hybrid and Hybrid_with_bb for client radius = 20, facility opening cost =25 penalty =20

Table 4.7: Runtime Comparison among CPLEX, Hybrid Program and Hybrid with BB(Branch and Bound) for a Covering problem Instance where radius = 30, facility opening cost = 13 and penalty = 22

Graph		Tree D		Runtime for CPLEX(s)	Subprob Size	Num of Dyn node	Runtime for Hybrid(s)	Runtime for Hybrid with BB(s)
IVI	IEI	INI	IEI					
516	582	514	513	0.437	75	70	22.715	21.337
					150	33	11.14	10.624
					200	13	6.51	6.28
					250	4	4.03	4.356
					300	1	1.98	2.212
1149	1323	1146	1145	0.879	200	226	81.361	72.045
					400	104	45.356	40.223
					600	3	9.828	9.203
					700	1	7.18	6.958
					500	206	92.521	77.875
2004	2283	2002	2001	1.967	800	108	52.585	46.851
					1000	52	33.286	28.551
					1200	4	5.74	5.318
					1500	1	3.822	3.645
					1000	397	304.47	291.832
3330	3810	3328	3327	4.704	1200	281	214.729	163.003
					1500	112	90.18	71.13
					2000	1	7.925	8.164
					2000	376	410.311	310.747
5254	6008	5252	5251	13.109	2500	76	104.99	83.929
					2800	1	16.497	15.239
					3000	1	16.177	15.24
					2500	264	684.553	522.308
8752	10004	8749	8748	39.761	3500	199	511.696	410.243
					5000	199	512.005	409.463
					6500	1	36.431	42.556

Table 4.8: Number of Permutations comparison between Hybrid Program and Hybrid with BB(Branch and Bound) for a Covering problem Instance where radius = 30, facility opening cost = 13 and penalty = 22

Graph				Tree D	Subprob Size	Perm data for Hybrid(s)			Perm data for Hybrid_BB(s)				
IVI	IEI	INI	IEI			Total perm	After pruning	Total pruned perm	Total perm	After pruning	Pruned by Pruning Heuristic	Pruned by BB	Total pruned perm
516	582	514	513		75	12310	11322	988	7064	4651	645	1768	2413
					150	5194	4832	362	3001	1866	228	907	1135
					200	2271	2075	197	1466	886	144	436	580
					250	888	830	58	771	424	91	256	347
					300	225	207	18	230	85	27	118	145
1149	1323	1146	1145		200	31882	29136	2746	15960	8931	1613	5416	7029
					400	18626	16766	1860	9058	4991	1142	2925	4067
					600	1996	1765	231	1024	452	192	380	572
					700	1240	1087	153	690	257	147	286	433
2004	2283	2002	2001		500	25207	23270	1937	12986	7464	1096	4426	5522
					800	14627	13442	1185	7664	4469	706	2489	3195
					1000	8652	7918	734	4695	2871	453	1371	1824
					1200	693	659	34	359	202	23	134	157
					1500	252	238	14	129	57	14	58	72
3330	3810	3328	3327		1000	53180	48787	4393	27044	15818	2532	8694	11226
					1200	37710	34513	3197	19074	11239	1817	6018	7835
					1500	15437	13867	1570	7817	4587	868	2362	3230
					2000	119	101	18	127	72	10	45	55
5254	6008	5252	5251		2000	40025	37175	2850	20582	11640	1645	7297	8942
					2500	8903	8189	714	4638	2584	477	1577	2054
					2800	140	140	0	61	16	0	45	30
					3000	125	125	0	61	16	0	45	45
8752	10004	8749	8748		2500	35325	32849	2476	18381	10995	1465	5921	7386
					3500	24613	23022	1591	12770	7561	944	4265	5209
					5000	24613	23022	1591	12770	7561	944	4265	5209
					6500	105	103	2	107	31	0	76	76

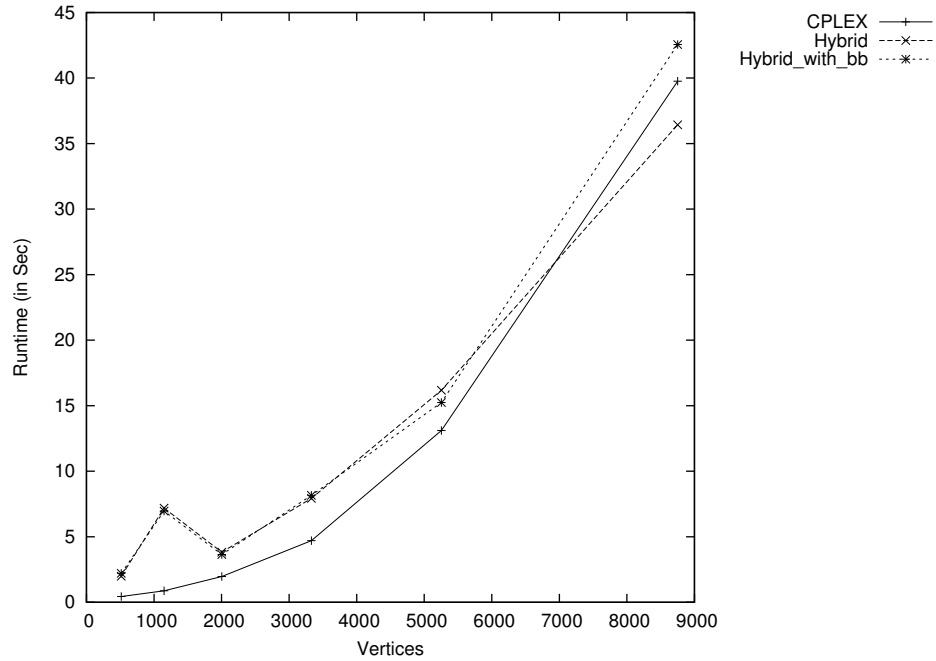

Figure 4.5: Runtime Comparison among CPLEX, Hybrid and Hybrid_with_bb for client radius = 30, facility opening cost =13 penalty =22

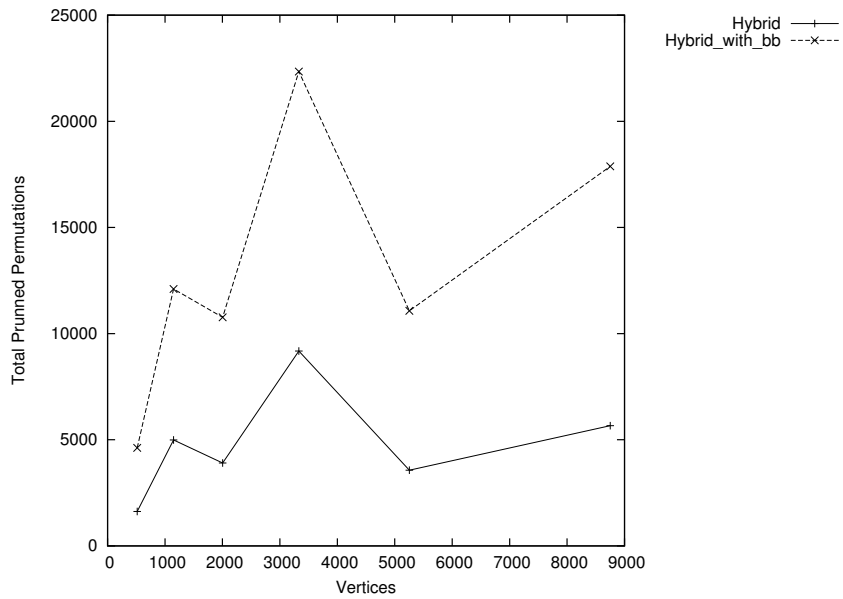

Figure 4.6: Permutation Comparison between Hybrid and Hybrid_with_bb for client radius = 30, facility opening cost =13 penalty =22

Table 4.9: Runtime Comparison among CPLEX, Hybrid Program and Hybrid with BB(Branch and Bound) for a Covering problem Instance where radius = 40, facility opening cost = 10 and penalty = 17

Graph		Tree D		Runtime for CPLEX(s)	Subprob Size	Num of Dyn node	Runtime for Hybrid(s)	Runtime for Hybrid with BB(s)
VI	EI	NI	EI					
516	582	514	513	0.396	75	70	30.931	29.052
					150	33	15.61	14.852
					200	13	10.002	9.571
					250	4	5.795	5.621
					300	1	3.11	3.092
1149	1323	1146	1145	1.188	200	226	108.034	94.75
					400	104	59.59	55.343
					600	3	11.868	10.659
					700	1	6.015	5.23
2004	2283	2002	2001	2.277	500	206	125.629	127.295
					800	108	74.792	76.894
					1000	52	45.022	45.241
					1200	4	9.706	9.467
					1500	1	6.543	5.911
3330	3810	3328	3327	5.074	1000	397	1571.985	1309.398
					1200	281	312.235	290.64
					1500	112	139.917	116.194
					2000	1	10.444	9.641
5254	6008	5252	5251	13.551	2000	376	612.082	653.461
					2500	76	155.037	153.788
					2800	1	22.436	20.924
					3000	1	19.062	23.162
8752	10004	8749	8748	38.332	2500	264	968.473	758.696
					3500	199	717.482	557.497
					5000	199	721.238	561.460
					6500	1	51.854	56.268

Table 4.10: Number of Permutations comparison between Hybrid Program and Hybrid with BB(Branch and Bound) for a Covering problem Instance where radius = 40, facility opening cost = 10 and penalty = 17

Graph				Tree D	Subprob Size	Perm data for Hybrid(s)			Perm data for Hybrid_BB(s)				
IVI	IEI	INI	IEI			Total perm	After pruning	Total pruned perm	Total perm	After pruning	Pruned by Pruning Heuristic	Pruned by BB	Total pruned perm
					75	20314	18202	2112	11456	7631	1341	2484	3825
					150	8741	7957	784	5142	3274	493	1375	1868
516	582	514	513		200	4224	3790	434	2474	1472	271	731	1002
					250	1647	1506	141	758	374	54	330	384
					300	333	290	43	243	94	18	131	149
					200	49702	44250	5452	27655	17572	3447	6636	10083
					400	28581	25096	3485	16446	10690	2321	3435	5756
1149	1323	1146	1145		600	1986	1734	252	1166	778	191	197	388
					700	735	890	145	369	185	107	77	184
					500	41955	37726	4229	41978	37734	4226	18	4244
					800	23073	20785	2288	23073	20778	2288	7	2295
2004	2283	2002	2001		1000	13333	11864	1469	13333	11857	1469	7	1476
					1200	1025	941	84	1125	1028	94	3	97
					1500	368	332	36	452	403	46	3	49
					1000	92888	83256	9631	47405	28933	5727	12745	18472
					1200	67861	60592	7269	35123	21814	4353	8956	13309
3330	3810	3328	3327		1500	29563	25920	3643	15451	9336	2132	3983	6115
					2000	212	174	38	119	50	12	57	69
					2000	69591	62546	7045	69090	61791	6909	390	7299
					2500	16053	14260	1793	15773	13994	1678	101	1779
5254	6008	5252	5251		2800	125	125	0	155	155	0	0	0
					3000	110	110	0	155	155	0	0	0
					2500	61936	56419	5517	30109	18083	3239	8787	12026
					3500	42456	39892	2564	21768	13535	2195	6038	8233
8752	10004	8749	8748		5000	43456	39892	3564	21708	13535	2195	6038	8233
					6500	360	349	11	235	49	8	178	186

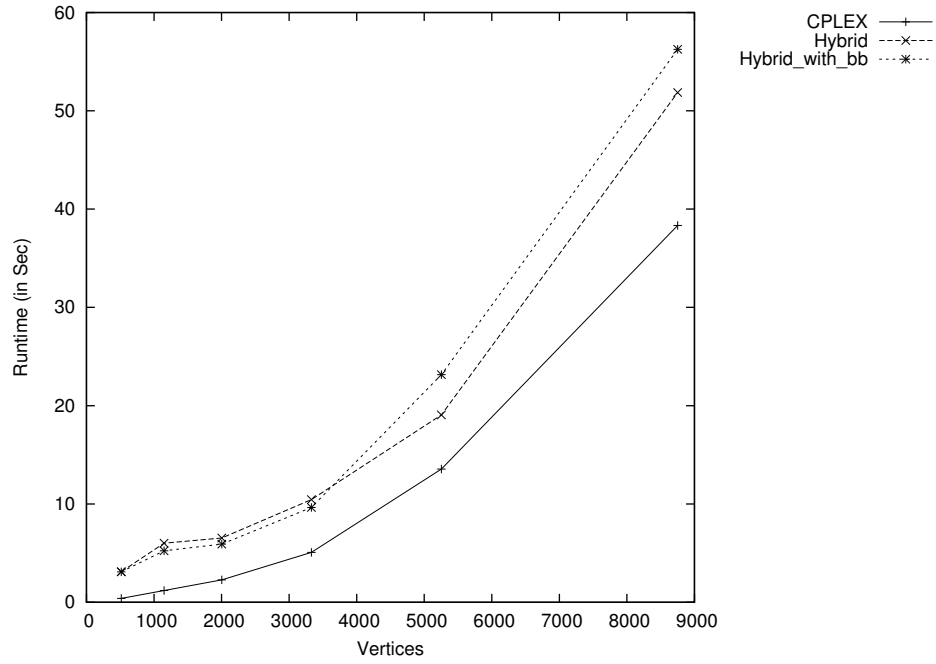

Figure 4.7: Runtime Comparison among CPLEX, Hybrid and Hybrid_with_bb for client radius = 40, facility opening cost =10 penalty =17

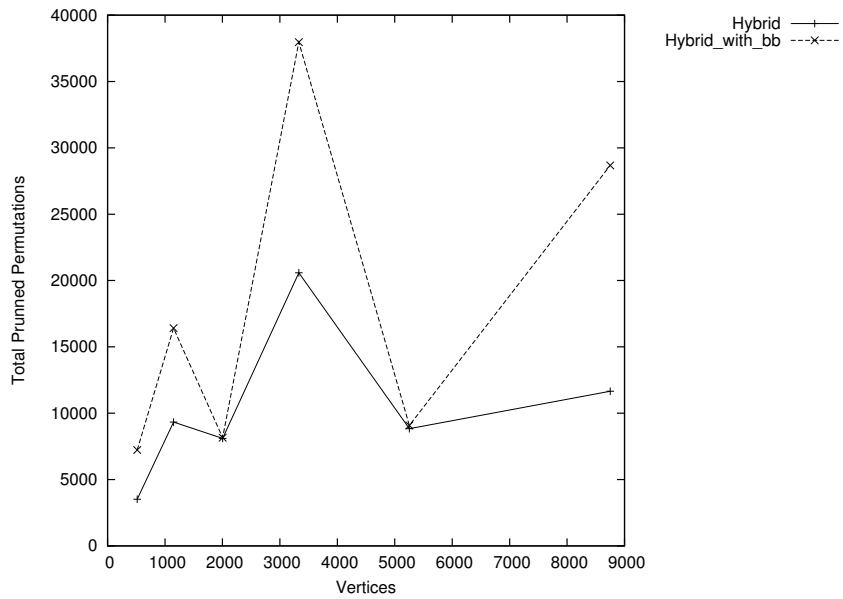

Figure 4.8: Permutation Comparison between Hybrid and Hybrid_with_bb for client radius = 40, facility opening cost =10 penalty =17

4.3 Analysis

In this section we will analyze the results described in the earlier data tables. In the following, we will discuss our findings after observing the data.

- As described in Chapter 3, if the treewidth of the Tree Decomposition is k , then for each Tree Decomposition node, there will be n^{k+1} number of cost functions (permutations). During the initial phase of the development, our algorithm used to generate and store a huge number of cost functions (before pruning) in accordance with the theoretical estimation n^{k+1} to solve a Covering Problem instance. After employing the techniques discussed in section 3.2.2 (*Reduction of cost functions based on Covering Neighborhood*) and in section 3.4.7 (*Bounding the Assignment Function*), we were able to decrease greatly the number of generated cost functions (permutations) even before pruning. For example, for a series-parallel graph (treewidth $k = 2$) of 516 nodes and 582 edges, according to our theoretical estimation, in the worst case, for a single node, the number of cost functions generated can be $516^3 = 137388096$. In table 4.3 and 4.4, for the same graph of 516 nodes and 582 edges, for a subproblem size of 75 (where the number of nodes processed by the dynamic program is 70) the total number of permutations generated by the Hybrid program is 3774 (for a Covering Problem instance where client radius = 10, facility opening cost = 15 and penalty = 20) which indicates a considerable amount of decrease in the generation of permutations (before pruning). For all the other experiments, the techniques discussed in section 3.2.2 and 3.4.7 greatly reduces the total number of cost functions or permutations(before pruning).
- After scrutinizing the table, we found a relation between the runtime of the programs (both Hybrid and Hybrid_with_bb) and the total number of generated permutations (before pruning) to the client radius. As the client radius increases, so as the total number of generated permutations (as well as the total number of processed permutations) which leads to a longer runtime. This is because as the client radius increases, so as the Covering Neighborhood of a Tree Decomposition node (described in section 3.2.2). As the cost function generator for

each node depends on the size of the Covering Neighborhood of that node, the larger the set of the Covering Neighborhood, the larger is the number of total permutations. As an example, In Figure 4.9, we plotted the data for the series-parallel graph with 3330 nodes and 3810 edges with different client radius (10,20,30,40) against the Hybrid runtime for subproblem size 2000 (from Table 4.1, 4.3, 4.5, 4.7). In Figure 4.10, we plotted the permutation data for subproblem size 1000 of the graph with nodes 3330 and edges 3810 (from Table 4.2, 4.4, 4.6, 4.8). In both the Figures, it is clear that the runtime and the number of permutations for this graph(with their respective size) increases with the client radius. This trend follow for both Hybrid and Hybrid_with_bb program with different graphs with different subproblem sizes.

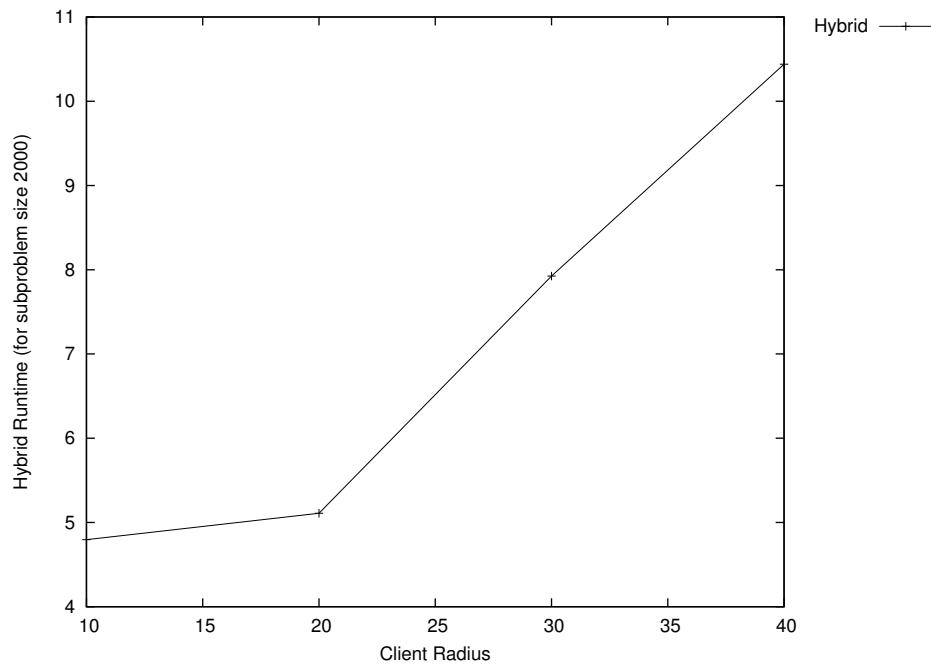

Figure 4.9: Client Radius Vs Runtime data of the Hybrid program for the graph with 3330 nodes with subproblem size 2000

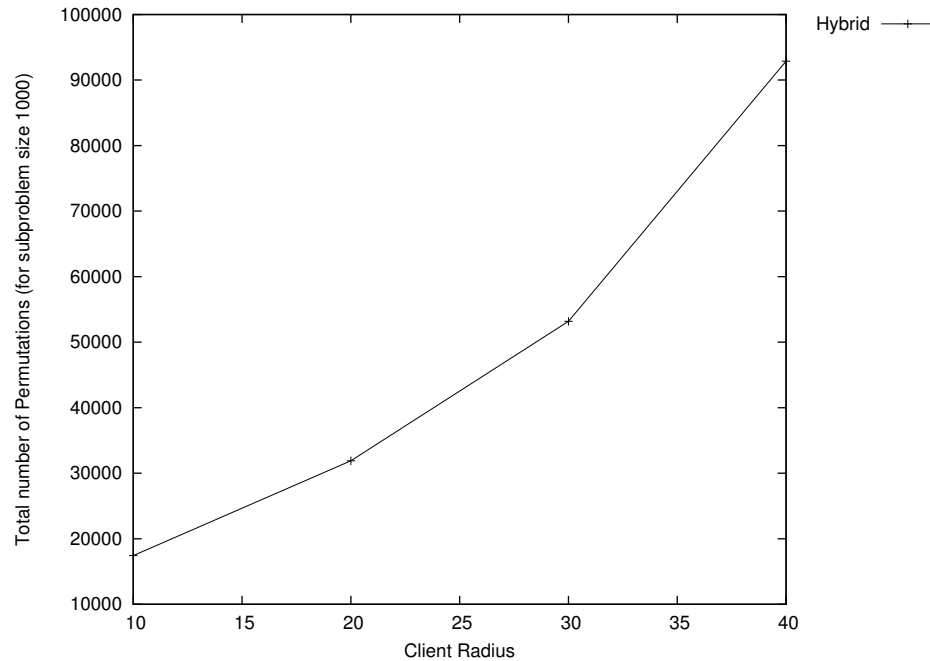

Figure 4.10: Client Radius Vs Total number of permutations of Hybrid Program for the graph with 3330 nodes with subproblem size 2000

- In case of smaller graphs (graphs with nodes 516, 1149, 2004, 3330) if we compare the running time between CPLEX, Hybrid and Hybrid_with_bb, then CPLEX beats both the program comfortably for all the Covering Problem Instances. But on larger graphs (graphs with nodes 5254, 8752) with smaller client radius (10,20) either Hybrid or Hybrid_with_bb beats CPLEX in terms of running time. This occurs whenever the subproblem size reaches the amount for which the dynamic program part of Hybrid and Hybrid_with_bb needs to process only one Tree Decomposition node (the root of the Tree Decomposition). This confirms that dynamic programming is very expensive when applied to an entire problem space (with respect to Covering Problem), but can be effective if it can be restricted to a subset of the problem space given that the rest was solved by a quick heuristic algorithm. This also leads us to the notion of partial Tree Decomposition and other future research interests which will be discussed in the conclusion chapter.

- After studying the number of total pruned permutation for the Hybrid and Hybrid_with_bb program, it is apparent that the program Hybrid_with_bb (equipped with the branch and bound technique) is pruning the generated permutations far more than the Hybrid program with branch and bound technique being the main contributor. The reason the branch and bound technique is so successful than the pruning heuristic is for series-parallel graphs the integrality gap between the integer and relaxed version of the Covering Problem is very small (≈ 0). So, the bounds generated by solving the relaxed subproblems in Hybrid_with_bb is very tight. As a result more number of cost functions are pruned by the branch and bound technique. Also, we noticed that the total number of generated permutations differs between the programs Hybrid and Hybrid_with_bb. This is because of the process that we used to mimic Nice Tree Decomposition. For example, given a original Tree Decomposition leaf node l with the size of the vertex set more than one, we pick a random vertex and make it the vertex set for the newly constructed Nice Tree Decomposition leaf node l' . Then we compute the set minus between the vertex set of l and l' and add them to the vertex set of l' to generate the vertex set of a newly constructed Introduce Node. This means while executing Hybrid and Hybrid_with_bb, the vertex ordering of the Nice Tree Decomposition nodes does not match. This leads to compute different bounds (as described in 3.4.7) for Hybrid and Hybrid_with_bb for the same node. As a result of these different bounds, the total number of permutations generated by Hybrid and Hybrid_with_bb for the same node will differ.

In this Chapter, we have presented the empirical data of the Tree Decomposition experiments and the Covering Problem experiments. We have compared the performance of different algorithms and mentioned our findings after evaluating the data. In the Conclusion chapter, we will talk about the implication of our research with future directions.

Chapter 5

Conclusion

In this thesis, we developed a dynamic programming algorithm to solve standard Covering Problem on a Tree Decomposition of a graph with the intuition that the unique properties of a Tree Decomposition would facilitate the design of the dynamic program. We developed a bottom up dynamic programming framework which utilizes the Tree Decomposition to build the solution. But for this approach to work, the the program needs to generate n^{k+1} ($k = \text{Treewidth}$) number of cost functions for each Tree Decomposition node. This leads to a shortage of memory to solve the Covering problem even on a small graph below 100 nodes.

To counter this problem, we developed few techniques that are added on top of the framework. These techniques considerably reduces the number of cost function per node. Though after employing this technique we solved the memory problem to an extent (the program was able to solve series-parallel graphs with thousands of nodes and edges considerably quickly), but this dynamic programming algorithm proved to be expensive when compared to other tools like CPLEX for solving the Covering Problem. CPLEX takes far less time than our dynamic program to solve Covering Problem on series-parallel graphs.

We then worked on several ideas to even out this difference of running time. One idea we implemented was to use the CONDOR grid (a high throughput system) to develop a parallel algorithm to solve the Covering Problem where each computer will solve a different subproblem and report back the solution back to the parent. But for Covering Problem, this technique was proved to be infeasible because CPLEX was already solving the Covering Problem very fast on series-parallel graphs. The experiment results from the parallel program didn't show any significant improvement. But we believe that this parallel algorithm will be useful for other more difficult facility location problems.

In our next idea, we decided to incorporate the power of CPLEX in our dynamic programming framework. We call this algorithm the Hybrid algorithm. The CPLEX module was used to solve all the subproblems (of a certain size) at the bottom part of the Tree Decomposition. After experimenting we got some success in this approach. When the client radius is small and the graph instance is quite large, then the Hybrid algorithm beats the CPLEX but not by a large margin. We experimented with two different versions of the Hybrid algorithm, one equipped with the branch and bound technique (*Hybrid_with_bb*) and the other version (*Hybrid*) without the branch and bound technique. *Hybrid_with_bb* fares better than *Hybrid* in smaller graphs but performs similarly in cases of large graphs. But almost in every case *Hybrid_with_bb* version prunes more cost functions than the *Hybrid* version. as the branch and bound technique is very useful on series-parallel graphs (integrality gap $\approx = 0$). But the preprocessing step for the *Hybrid_with_bb* is expensive in terms of running time as the bounds for each Tree Decomposition node are pre-computed and saved in a file.

In cases where the *Hybrid* version beats CPLEX, the number of node processed by the dynamic programming technique is always one (the root of the Tree Decomposition). This shows that the dynamic program is indeed expensive if it solves the greater part of the Tree Decomposition but can be effective if it can be restricted to solve a few number of nodes (in our case the root). Though it beats CPLEX marginally but given the fact that on series-parallel graphs CPLEX is very effective, this is a success none the less. Moreover this finding will also guide us to our future endeavors.

As solving only the root of Tree Decomposition using Dynamic programming gives the Hybrid program the edge over CPLEX, it is evident that we don't require a full Tree Decomposition of a graph. Instead a partial Tree Decomposition which will contain a few nodes with equally balanced subproblem size would do the trick. This partial Tree Decomposition will involve finding a small separator for the input graph where the divided components will be balanced. In this respect, we can try to find a centroid or a geometric center of a tree decomposition and make it a separator. Then the divided components will be balanced in size because they are equally distanced from the center. This separator will work as a root of this construct. We can involve CPLEX or other methods

to build solution of the subproblems defined by the components. In this way, after finding a small separator, we can even handle graphs with larger Treewidth.

Our future plan will include finding and developing efficient methods for finding small size separator of a graph. We plan to use our current algorithm to solve covering problem on real world wireless network data to check it's effectiveness. We can also extend our algorithm for P-median problem (a facility location problem similar to Covering problem) if the experiments are successful. Also we would like to apply the parallel programming algorithm on much harder facility location problems for which we believe the technique will be quite effective.

Bibliography

- [1] R. K. Ahuja, T. L. Magnanti, and J. B. Orlin. Network flows: theory algorithms and applications. 1993.
- [2] Anne Berry, Pinar Heggernes, and Geneviève Simonet. The minimum degree heuristic and the minimal triangulation process. In *Workshop on Graph-Theoretic Concepts in Computer Science*, pages 58–70, 2003.
- [3] Jean R.S. Blair, Pinar Heggernes, and Jan Arne Telle. A practical algorithm for making filled graphs minimal. *Theoretical Computer Science*, 250(1-2):125 – 141, 2001.
- [4] Hans L. Bodlaender. A tourist guide through treewidth. *Acta Cybernetica*, 11:1–23, 1993.
- [5] Hans L. Bodlaender. Treewidth: Algorithmic techniques and results. pages 19–36, 1997.
- [6] Brent N. Clark, Charles J. Colbourn, and David S. Johnson. Unit disk graphs. *Discrete Mathematics*, 86(1-3):165–177, 1990.
- [7] William Cook and Paul D. Seymour. Tour merging via branch-decomposition. *INFORMS Journal on Computing*, 15(3):233–248, 2003.
- [8] David Eppstein. Parallel recognition of series-parallel graphs. *Inf. Comput.*, 98:41–55, May 1992.
- [9] D. R. Fulkerson and O. A. Gross. Incidence matrices and interval graphs. 1965.
- [10] F. Gavril. The intersection graphs of subtrees in tree are exactly the chordal graphs. *Combinatorica*, 1974.
- [11] Michel Habib, Ross McConnell, Christophe Paul, and Laurent Viennot. Lex-bfs and partition refinement, with applications to transitive orientation, interval graph recognition and consecutive ones testing. *Theor. Comput. Sci.*, 234:59–84, March 2000.
- [12] Finn V. Jensen, Steffen L. Lauritzen, and Kristian G. Olesen. Bayesian updating in causal probabilistic networks by local computations. *Computational Statistics Quarterly*, 4:269–282, 1990.
- [13] Jon Kleinberg and Eva Tardos. *Algorithm Design*.
- [14] Antoon Kolen. Solving covering problems and the uncapacitated plant location problem on trees. *European Journal of Operational Research*, 12(3):266 – 278, 1983.
- [15] Antoon Kolen and Arie Tamir. Covering problems. *Discrete location theory*, 263-304 (1990)., 1990.
- [16] A. M. C. A. Koster. *Frequency Assignment - Models and Algorithms*. PhD thesis, Maastricht University, 1999.
- [17] A.M.C.A. Koster, van Hoesel, S.P.M., and A.W.J. Kolen. Solving frequency assignment problems via tree-decomposition. Research Memoranda 036, Maastricht University, 1999.

- [18] Arie M. C. A. Koster, Hans L. Bodlaender, and Stan P. M. Van Hoesel. Treewidth: Computational experiments. *Electronic Notes in Discrete Mathematics*, 8:54–57, 2001.
- [19] Arie M.C.A. Koster, Stan P.M. van Hoesel, and Antoon W.J. Kolen. Lower bounds for minimum interference frequency assignment problems. Open access publications from maastricht university, Maastricht University, 2000.
- [20] A. H. Land and A. G. Doig. An automatic method of solving discrete programming problems. *Econometrica*, 28(3):pp. 497–520, 1960.
- [21] S. L. Lauritzen and D. J. Spiegelhalter. Local computations with probabilities on graphical structures and their application to expert systems. *Journal of the Royal Statistical Society. Series B (Methodological)*, 50(2):pp. 157–224, 1988.
- [22] Karl Menger. Zur allgemeinen kurventheorie. *Fundamenta Mathematicae*, 10, 1927.
- [23] A. B. Murdasov. A simple algorithm for finding the center of a tree. *Cybernetics and Systems Analysis*, 12:157–158, 1976. 10.1007/BF01070358.
- [24] S. Parter. The use of linear graphs in gauss elimination. *Siam Review*, 3, 1961.
- [25] Neil Robertson and P. D. Seymour. Graph minors: X. obstructions to tree-decomposition. *J. Comb. Theory Ser. B*, 52:153–190, June 1991.
- [26] Neil Robertson and Paul D. Seymour. Graph minors. i. excluding a forest. *J. Comb. Theory, Ser. B*, 35:39–61, 1983.
- [27] Neil Robertson and Paul D. Seymour. Graph minors. ii. algorithmic aspects of tree-width. *J. Algorithms*, 7:309–322, 1986.
- [28] Neil Robertson and Paul D. Seymour. Graph minors .xiii. the disjoint paths problem. *J. Comb. Theory, Ser. B*, 63:65–110, 1995.
- [29] Arie Tamir. An $o(pn^2)$ algorithm for the p-median and related problems on tree graphs. *Operations Research Letters*, 19(2):59 – 64, 1996.
- [30] Dallas Thomas. Algorithms & experiments for the protein chain lattice fitting problem. 2006.
- [31] Abraham Michiel Verweij. *Selected Applications of Integer Programming: A Computational Study*. PhD thesis, Utrecht University, Utrecht, The Netherlands, 2000.