

**A RE-EXAMINATION OF THE RETROSPLENIAL  
CONTRIBUTION TO PLACE NAVIGATION IN THE RAT**

**KENNETH TROY HARKER**

**Bachelor of Science, University of Lethbridge, 2000**

A Thesis

Submitted to the School of Graduate Studies  
of The University of Lethbridge  
in Partial Fulfillment of the  
Requirements for the Degree

**MASTER OF SCIENCE**

LETHBRIDGE, ALBERTA

July, 2002

© Kenneth Troy Harker, 2002

## DEDICATION

*To Jennifer, my friend, my love, my wife.*

*And to my parents for instilling in me the desire  
to learn.*

## ABSTRACT

Behavioural, electrophysiological, and anatomical evidence suggests that retrosplenial (RS) cortex (areas RSA and RSG) plays a role in spatial navigation. It has been recently suggested that it is damage to the underlying cingulum bundle (CG) (areas CG and IG), and not RS, that disrupts spatial place learning. I revisited this issue by comparing the rat strains and lesions used in studies that typically report RS deficits, to those used in studies in which no RS deficit is reported. I found both selective RS damage and selective CG damage to disrupt spatial behaviour, suggesting independent contributions to spatial learning and memory from both of these structures. Further, previous failures to find RS deficits are shown to be the result of an inappropriate choice of rat strain for studying normal brain-behaviour relationships combined with a failure to use appropriate testing methods for assessing spatial behaviour.

## ACKNOWLEDGEMENTS

I would like to first and foremost acknowledge the guidance and mentoring of my supervisor, Ian Wishaw, and to say thank you for teaching me “how to do science.”

I would also like to thank the members of my supervisory committee, Glen Prusky & Andy Hurley, for their insight and input into the direction of my thesis. I would also like to acknowledge the many people who provided significant instruction or assistance with various aspects of my thesis (in alphabetical order): Dawn Danka (Histology), Bogdan Gorny (Behaviour), Grazyna Gorny (Histology), Joanna Gorny (Histology), Reed Kindt (Technical), Tanya Arjannikova (Visual Acuity), Rob Sutherland (Methodology), Paul Wishaw (Multimedia).

## TABLE OF CONTENTS

Title Page	i
Signature Page	ii
Dedication	iii
Abstract	iv
Acknowledgements	v
Table of Contents	vi
List of Tables	vii
List of Figures	viii
List of Abbreviations	x
<b>Chapter 1.</b> General Introduction.	p. 1
<b>Chapter 2.</b> Impaired Spatial Performance in Rats with Retrosplenial Lesions: Importance of the Spatial Problem and the Rat Strain in Identifying Lesion Effects in a Swimming Pool.	p. 24
<b>Chapter 3.</b> Impaired place navigation in place and matching-to-place swimming pool tasks follows both retrosplenial cortex lesions and cingulum bundle lesions in rats.	p. 71
<b>Chapter 4.</b> General Discussion.	p. 99
<b>References</b>	p. 126

## LIST OF TABLES

<b>Table 4.1.</b>	A history of the study of retrosplenial cortex involvement in spatial behaviour.	p. 103
-------------------	--	--------

## LIST OF FIGURES

- Figure 1.1.** Structures in the Papez circuit shown to be involved in spatial learning and memory p. 5
- Figure 1.2.** Swimming pool place task p. 11
- Figure 1.3.** Swimming pool matching-to-place task p. 13
- Figure 1.4.** Neural pathways to the hippocampus p. 18
- Figure 2.1.** Representative histological results showing a normal brain (*A*), a selective retrosplenial cortex aspiration lesion (*B*), and a combined retrosplenial cortex + cingulum bundle aspiration lesion (*C*) p. 35
- Figure 2.2.** Place task latencies: Retrosplenial aspiration versus retrosplenial + cingulum bundle aspiration p. 39
- Figure 2.3.** Probe measures: Retrosplenial aspiration versus retrosplenial + cingulum bundle aspiration p. 41
- Figure 2.4.** Matching-to-place latencies: Retrosplenial aspiration versus retrosplenial + cingulum bundle aspiration p. 43
- Figure 2.5.** Place task latencies: The effects of pre-training on retrosplenial spatial deficits p. 47
- Figure 2.6.** Probe measures: The effects of pre-training on retrosplenial spatial deficits p. 50
- Figure 2.7.** Matching-to-place latencies: The effects of pre-training on retrosplenial spatial deficits p. 52

- Figure 2.8.** Place task latencies: Strain comparison between Long-Evans, Dark Agouti, and Dark Agouti retrosplenial rats p. 56
- Figure 2.9.** Probe measures: Strain comparison between Long-Evans, Dark Agouti, and Dark Agouti retrosplenial rats p. 58
- Figure 2.10.** Matching-to-place latencies: Strain comparison between Long-Evans, Dark Agouti, and Dark Agouti retrosplenial rats p. 61
- Figure 2.11.** Visual acuity of Long-Evans, Dark Agouti, and Long-Evans retrosplenial rats p. 63
- Figure 3.1.** Representative histological results showing a normal brain (*A*), a selective cytotoxic NMDA retrosplenial cortex lesion (*B*) p. 80
- Figure 3.2.** Representative histological results showing a normal brain (*A*), a surgical knife-cut cingulum bundle lesion (*B*) p. 82
- Figure 3.3.** Place task latencies: retrosplenial NMDA versus cingulum bundle transection p. 85
- Figure 3.4.** Probe measures: retrosplenial NMDA versus cingulum bundle transection p. 87
- Figure 3.5.** Matching-to-place performance: retrosplenial NMDA versus cingulum bundle transection on measures of latency (*A*), and swim trajectory errors (*B*) p. 90



## LIST OF ABBREVIATIONS

<b>cc</b>	=	corpus callosum
<b>CG</b>	=	cingulum bundle
<b>Cg1/Cg2</b>	=	anterior cingulate cortex
<b>M1/M2</b>	=	motor association cortex
<b>MWT</b>	=	Morris Water Task
<b>NMDA</b>	=	n-methyl-d-aspartate
<b>OC2</b>	=	visual association cortex
<b>RAD</b>	=	Radial Arm Maze
<b>RS</b>	=	Retrosplenial cortex (posterior cingulate cortex)

## CHAPTER ONE

### GENERAL INTRODUCTION

#### **Overview**

I have designed this chapter in such a way as to describe the issues surrounding retrosplenial cortex and its role in spatial learning by starting from a discussion of general learning and memory concepts and neural substrates and building into the more specific questions and problems posed by investigations of the neural circuitry mediating spatial learning and memory. By doing so, I place the retrosplenial question into its proper context of general learning and memory, thus providing the important background as to how the retrosplenial question has developed. In accordance with this design, I begin this chapter with a general definition of the terms “learning” and “memory” as well as some of the major classifications of these terms. This is followed by a discussion of the brain structures that are involved in learning and memory with respect to evidence from both human and animal models. In particular, I describe the importance of the hippocampal formation and related structures in the Papez circuit for various types of spatial memory, along with a description of some of the spatial tasks relevant to this particular thesis. From here I describe in further detail the dilemma concerning hippocampal input pathways for information relevant to spatial processing, with especial interest in the retrosplenial cortex pathway. Finally I end this chapter with a description of the objectives of this thesis.

### **Learning and memory defined**

Learning is defined as a process that produces relatively permanent changes in the behaviour of an organism as a result of experience, whereas memory is defined as the ability to recognize or recall this experience (Kolb & Whishaw, 2001). The term memory in general, is often associated with the processes of learning, storing, recall and forgetting of information. Learning and memory is often divided into two major classifications: explicit memory (of which one is consciously aware – e.g. factual based knowledge) and implicit or procedural memory (of which one is not aware – e.g. learning a skill, or procedure) based upon medial temporal lobe circuitry and basal ganglia-thalamic-frontal lobe circuitry respectively (Kolb & Whishaw, 2001).

### **The neural basis of memory – Human Models**

The first formal investigation of the neural basis of memory was conducted by Karl Lashley who spent over thirty-five years carrying out hundreds of experiments that failed to disrupt specific memories. These failures lead Lashley to the conclusion that memory is stored globally throughout the brain (Lashley, 1950). In 1953 Scoville and Milner (1957) reported a case study describing a patient with severe anterograde amnesia following bilateral surgical transection of the medial temporal lobes that included the anterior portions of the hippocampus. The patient H.M. displayed a lasting, severe impairment in the ability to form or store new explicit memories, but not implicit memories, suggesting a dissociation between the neural circuitry mediating implicit and explicit memory. The evidence from case studies such as that of H.M. where

hippocampal damage impairs the formation and storage of new memories places the hippocampus into the centre of the neural basis of learning and memory.

### **Animal models of learning and memory**

More recent evidence in primates suggests that the memory impairments displayed by patients with medial temporal lobe damage are more likely the result of damage to perirhinal cortex, than damage to the hippocampus itself (Meunier, Bachevalier, Mishkin, & Murray, 1993). Further, animal studies using rats attempting to replicate the learning and memory impairments displayed by H.M. using selective hippocampal lesions have only been successful in recreating the deficits in spatial behaviour (the navigation to, or location of objects in space) displayed by H.M.. In their now classic book, *The Hippocampus as a Cognitive Map*, O'Keefe and Nadel (1978) proposed that the hippocampus was the central brain structure for mediating spatial navigation. Subsequently, this hypothesis has been supported by a mass of experimental evidence in both humans and nonhuman animals implicating the hippocampal formation (hippocampus and its interrelated structures – see description of the Papez circuit below) in both allothetic and ideothetic forms of spatial navigation (Morris, Garrud, Rawlins, & O'Keefe, 1982; Maguire, Frackowiak, & Frith, 1996; McNaughton *et al.*, 1996; Maguire, Frackowiak, & Frith, 1997; Whishaw, McKenna, & Maaswinkel, 1997; O'Keefe, Burgess, Donnett, Jeffery, & Maguire, 1998).

## **The hippocampus and the Papez circuit**

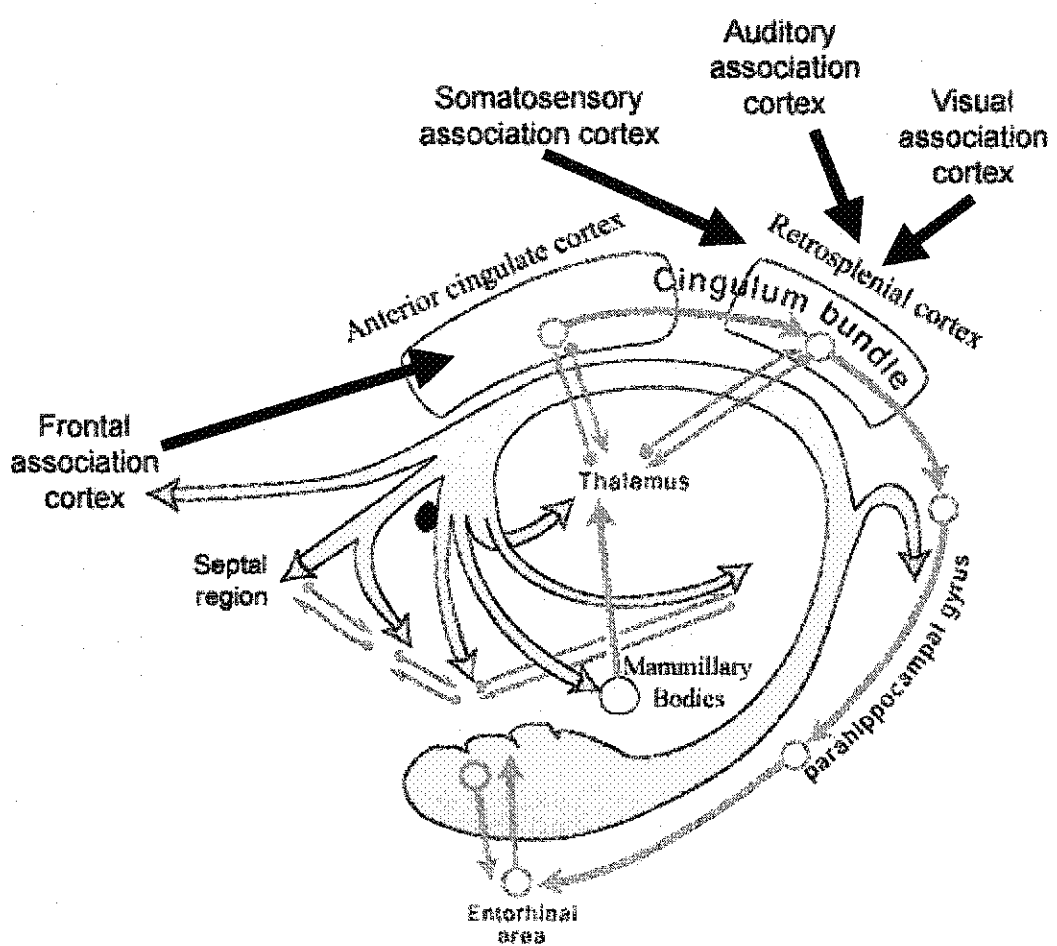
Many of the structures interrelated to the hippocampus also form part of the Papez circuit (Papez, 1937). The Papez circuit is a subcortical-cortical loop with information travelling from the hippocampal formation to the fornix, then to the mammillary bodies of the hypothalamus, then to the anterior dorsal thalamus, then via the cingulum bundle, to cingulate cortex, then to the rhinal cortices and finally back to the hippocampal formation (Fig. 1.1). Papez originally described this anatomical circuit as the neural substrate of emotion. Subsequent research however, suggests that damage to this circuit is more likely to disrupt learning and memory than it is emotion (Barker & Thomas, 1965; O'Keefe & Nadel, 1978; Morris *et al.*, 1982; Valenstein *et al.*, 1987; Sutherland, Whishaw, & Kolb, 1988; Sutherland & Rodriguez, 1989; Aggleton, Hunt, & Shaw, 1990; Whishaw *et al.*, 1997; Sziklas & Petrides, 1998).

## **Types of spatial learning and memory**

### **Taxon navigation (Routes)**

Taxon navigation is a form of navigation in which an animal is guided to a location by the use of cues and landmarks. Cued responses are movements in space that are guided by one or more external cue. Cues may be visual (e.g. the sun, moon, stars, and landmarks), auditory, or olfactory. Spatial behaviours based on the taxon navigation system occur as a series of specific responses guided by a given sequence of cues or landmarks. O'Keefe and Nadel (1978) refer to taxon navigation as a route generating system, and describe a route as a set of stimulus-response-stimulus instructions. In other words, animals learn to find objects or locations in the environment by following a set of

**Figure 1.1.** Diagram of the intrinsic hippocampal circuitry including interrelated structures in the Papez circuit shown to be involved in spatial learning and memory (grey arrows) along with cortical inputs to this circuitry (black arrows).



cue-movement-cue instructions. For example, the directions for how to get from point A to point B may be as follows: From the school (stimulus) head west five hundred meters (response) until you arrive at the church (stimulus) turn right (response) onto a dirt trail (stimulus)... etc. According to O'Keefe and Nadel (1978) the taxon navigation system requires the use of both allocentric and egocentric movements through space. One of the problems with using taxon navigation is the inflexibility of a route. This means that if a subject becomes lost by missing an instruction or because a landmark has been damaged or is missing, then it is unlikely that the subject will reach the desired endpoint of the route. Unlike the locale and path integration navigation strategies described below, cue navigation appears to be independent of both cortical input and normal hippocampal functioning (Whishaw & Kolb, 1984).

### **Locale navigation**

Locale navigation, at its simplest, is a form of navigation in which a subject is able to locate one object or place in relation to two or more surrounding objects or cues. This type of learning and memory is thought to rely on allothetic cues. Locale navigation does not rely upon a set of 'stimulus-response-stimulus' instructions as employed in non-hippocampal dependent cue navigation. Spatial behaviours supporting locale navigation are proposed to be based on a cognitive mapping system (O'Keefe & Nadel, 1978). According to O'Keefe and Nadel (1978) a mapping system requires two basic components: the map and a system for updating and locating places on the map. O'Keefe (1983) describes a spatial map as "a set of place representations and a subsystem for



relating these representations to each other in terms of their relative spatial location.”

Simply stated, a cognitive or spatial map is a representation of a part of space.

Locale navigation allows for flexibility, rapid change, and the retrieval of context-specific information; all of which do not occur with taxon navigation. A mapping strategy becomes problematic in unstable environments where cues and landmarks may be moved or altered at random. In such a situation, the inability to form a reliable cognitive map decreases the efficacy of place navigation.

### **Path Integration**

Path integration is a form of spatial navigation in which the subject is guided by internal or ideothetic cues generated by their own movements (Darwin, 1873; Barlow, 1964; Mittelstaedt & Mittelstaedt, 1980; Seguinot, Maurer, & Etienne, 1993). Path integration uses information from muscle, joint, and tendon receptors, vestibular input, flow of optic, auditory, olfactory stimuli, as well as efference copy information derived from structures that mediate movements (Whishaw, 2000). Using these self-movement generated cues during an outbound trip, a subject is able to not only determine its present position, but also the most direct route home. Recent evidence also suggests that path integration is dependent upon an intact hippocampus (Whishaw *et al.*, 1997; Whishaw, 2000).

### **Spatial learning and memory tests**

Tests of spatial learning and memory typically require a subject to either locate food at various locations, or to learn to the location of an escape refuge based on

allothetic (external) cues, ideothetic (internal cues), or both. Spatial learning tasks also employ a variety of testing arenas including mazes, foraging tables, and swimming pools (see Chapter Four for a more general discussion of spatial tasks). One of the most commonly used tasks for testing spatial learning and memory however, is the Morris swimming pool task.

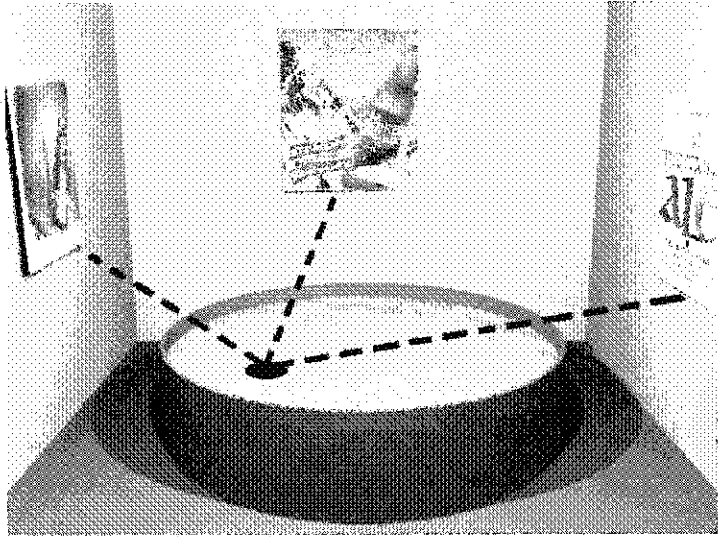
The swimming pool place task provides an ideal medium for investigating spatial learning and memory in rats (Morris, 1981). The Norway rat is an uncommonly good swimmer, adopting a species-typical swimming posture very early in ontogeny (Whishaw, Kolb, & Sutherland, 1983). Observations of colonies in the wild are consistent with the observations of the swimming effectiveness of rats in the laboratory (Galef, 1980). A colony of wild Norway rats living near a fish hatchery has been documented that actually performed so well in swimming that the rats competed very successfully with trout for surface food (Cottam, 1948), and colonies of Norway rats living along the Po river swim in the river, diving for molluscs living on the river bottom (Gandolfi & Parisi, 1972). There are additional reports of rats using swimming, while compensating for river current, to travel within their territories (Whishaw & Whishaw, 1996).

Designed as a task of spatial learning and memory, the place task allows a rat to escape from a swimming pool only if it finds a platform hidden just below the surface of the water at a fixed location in the swimming pool (Morris, 1984; Sutherland & Dyck, 1984) (Fig. 1.2). This task is advantageous for a number of reasons. First, the task is neutral, in that spatial behaviour has not been specifically bred or selected for in rats, thus providing an unbiased tool for comparing different rat strains. Second, the task allows

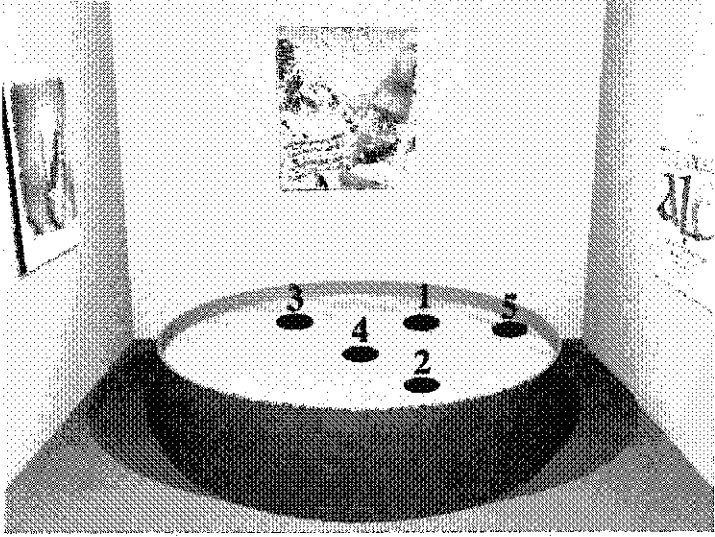
for maximal reduction of extraneous factors. Motivational factors are reduced because rats are intrinsically motivated to escape from water. As well, the influence of external factors shown to influence learning and memory, such as a partial reinforcement history (Gonzalez, Kolb, & Whishaw, 2000), hypothermia (Rauch, Welch, & Gallego, 1989) and stress (Holscher, 1999), can all be minimized by the use of a two-trials-per-day procedure that requires the animals be only briefly exposed to task demands (see methods sections from chapters two and three).

Further, the swimming pool task encompasses three components of spatial learning: procedural learning, spatial working memory, and retention. Procedural memory or nonspatial learning in the task is demonstrated by learning to swim away from the wall of the pool, learning that there is a platform providing escape, and learning to effectively search for the platform (Whishaw, 1985b). A nonspatial component of place learning has been referred to as nonspatial learning, and so the place task provides insights to this aspect of the learning process (Saucier, Hargreaves, Boon, Vanderwolf, & Cain, 1996; Cain, 1997; Hoh & Cain, 1997). In the matching-to-place version of the task, the subject learns to swim to a new location every day for a number of days, which provides an assessment of spatial working memory (Whishaw, 1985a) (Fig. 1.3). Retention of place learning is typically measured using a probe trial in which an animal indicates response strength by searching for a platform that has been removed from swimming pool (Sutherland, Kolb, & Whishaw, 1982).

*Figure 1.2.* The swimming pool place task requires subjects to locate the position of the hidden platform relative to cues in the testing room. During the place task the platform remains in a fixed position relative to the room cues across all trials.



*Figure 1.3.* Daily platform positions during the Matching-to-Place task in a swimming pool. During matching-to-place testing subjects must learn the new location of the platform in one trial, with optimal performance reflected by relatively higher trial 1 latencies (suggesting memory for the old platform location) and low trial 2 latencies (suggesting learning of the new location).



### Inputs to the hippocampus

That spatial navigation depends upon a variety of information is illustrated by the following case study of a patient with a stroke affecting the retrosplenial cortex (a controversial input for spatial processing to the hippocampus – and also the focal point of this thesis):

“The 55 year old right-handed man had been working as a taxicab driver in Kawasaki for 6 years. On January 12, 1993, as he was driving his taxi in the same city, he suddenly lost his understanding of the route to his destination. As he could quickly recognize the buildings and landscape around him, he was able to determine his current location. However, he could not determine in which direction he should proceed. He stopped taking passengers and tried to return to the main office, but didn't know the appropriate direction in which to drive. Using the surrounding buildings, scenery, and road signs he eventually arrived back at the office, although he made several mistakes along the way. He remembered, during this time, passing the same places over and over again. The next day when he left his house to receive a medical examination at a neighbourhood hospital, he could not determine whether he should go left or right, so he was obliged to take a taxicab...Even after being hospitalised he had trouble determining the location of rooms in the hospital” (p. 465)

From Takahashi *et al.* (1997)

As can be seen from this case study it is not sufficient just to be able to “recognize” features of the environment for accurate spatial navigation. The spatial learning and memory impairments displayed by this patient show an impairment of topographical orientation (as described in the human literature) or more simply place/locale navigation. As mentioned earlier, locale navigation is a form of navigation in which a subject is able to locate one object or place in relation to two or more surrounding objects. If the hippocampus or any of its circuitry has received damage, however, place navigation is severely impaired (O'Keefe & Nadel, 1978; Morris *et al.*, 1982; Sutherland *et al.*, 1988; Sutherland & Rodriguez, 1989; Whishaw *et al.*, 1997).



In spite of the abundant evidence that the hippocampus mediates spatial behaviour there is a question concerning how information necessary for spatial processing reaches the hippocampus (see Fig. 1.1 for hippocampal circuitry and inputs) (Aggleton, Vann, Oswald, & Good, 2000). The demonstration that impaired place learning but not cue learning (a simpler form of navigation in which the subject navigates towards or away from a single cue without regard to the surrounding environment) in decorticate rats (Whishaw & Kolb, 1984) suggests the necessity of a cortical input to the hippocampus for place navigation. Paradoxically however, most evidence suggests that damage to the cortical areas that link the neocortex and hippocampal formation (including the retrosplenial, entorhinal, perirhinal, and postrhinal cortices) fail to disrupt spatial behaviour (Aggleton *et al.*, 2000).

There are four possible solutions to this discrepancy: (1) Cortical input is not necessary for spatial behaviour, a highly unlikely solution given the spatial impairments observed in decorticate rats. (2) A cortical structure other than the retrosplenial or rhinal cortices provides the input pathway to the hippocampal formation. Although possible, this solution is also unlikely as anatomical evidence heavily favours the previously mentioned structures. (3) The suggestion made by Aggleton *et al.* (2000) that the retrosplenial and rhinal cortices work in concert as the input pathway, thus damage to just one of these areas would be insufficient to disrupt spatial behaviour as the remaining intact regions would still be there. Although this solution is plausible, it is not the most parsimonious especially given the evidence of rhinal cortex involvement in the medial temporal lobe circuitry mediating explicit memory. (4) One of these prime cortical candidates is involved in linking cortical and subcortical structures mediating spatial

navigation, however as of yet there is insufficient evidence to clearly demonstrate its role. It is this last possibility to which the present thesis is directed.

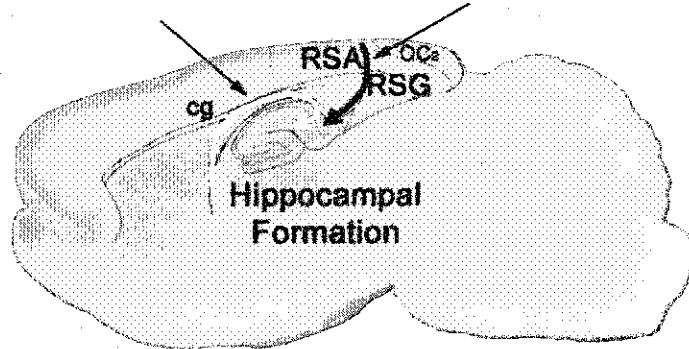
### **Retrosplenial cortex and spatial learning**

The best candidate for a cortical input of information relevant to spatial processing as evidenced in the human literature is the retrosplenial area of the posterior cingulate cortex (RS) (Valenstein *et al.*, 1987; Maguire, 2001; Mesulam, Nobre, Kim, Parrish, & Gitelman, 2001). Given the pivotal anatomical position of RS and connectivity between the hippocampal formation and associational cortical areas receiving both visual, sensory, and motor information, RS is ideally situated to bridge information between these areas (Domesick, 1969; Vogt & Miller, 1983; Pakhomova & Akopian, 1985; Wyss & Van Groen, 1992) (Fig. 1.2). Further, as demonstrated in the above case study, RS damage in humans produces impairments in spatial behaviour that are thought to be hippocampal dependent.

Evidence from the animal literature concerning the RS contribution to spatial behaviour however, has been controversial. Initial behavioural studies in rats finding RS deficits (Sutherland *et al.*, 1988; Kolb & Whishaw, 1991; Sutherland & Hoising, 1993) were later proposed to be the result of damage to the underlying cingulum bundle (CG) (Neave, Lloyd, Sahgal, & Aggleton, 1994; Aggleton, Neave, Nagle, & Sahgal, 1995; Warburton, Aggleton, & Muir, 1998), a fibre pathway linking various structures in the Papez circuit (Papez, 1937) (Fig. 1.1), and thus quite likely to play a role in spatial behaviour, a suggestion that has recently been supported by a number of lesion studies (Aggleton *et al.*, 1995; Neave, Nagle, & Aggleton, 1997; Warburton *et al.*, 1998).

*Figure 1.4.* Theories of neural inputs to the hippocampal formation with information relevant to spatial processing. The initial theory of a retrosplenial pathway (black) versus the more commonly accepted theory of the cingulum pathway (white).

*Cingulum Pathway*      *Retrosplenial Pathway*



Nevertheless, behavioural and physiological evidence from both humans (Takahashi *et al.*, 1997; Maguire, 2001; Mesulam *et al.*, 2001; Ino *et al.*, 2002) and animals (Chen, Lin, Barnes, & McNaughton, 1994a; Chen, Lin, Green, Barnes, & McNaughton, 1994b; Cho & Sharp, 2001; Cooper & Mizumori, 2001; Whishaw, Maaswinkel, Gonzalez, & Kolb, 2001) suggests the need for a re-examination of the contribution of retrosplenial cortex to place navigation in the rat.

### **Objectives**

The objectives of this thesis were to determine (1) if retrosplenial cortex is in fact involved in spatial behaviour, and (2) why the consistent contradictory results that appear in the literature concerning the behavioural outcomes of retrosplenial lesions on spatial tasks.

To achieve the objectives of this thesis I re-examined the role of retrosplenial cortex in spatial navigation by investigating and comparing the differences between studies that have typically found retrosplenial spatial deficits with those studies that have not. The differences between these two sets of studies include differences in the type of task, lesion, and strain. Studies that have typically reported retrosplenial deficits have done so using an aspiration lesion technique on Long-Evans rats tested on place and matching-to-place tasks in the Morris swimming pool task. Studies that have typically failed to find retrosplenial deficits have used a cell specific neurotoxic N-methyl-D-aspartate (NMDA) lesion on Dark Agouti rats tested on a number of tasks (with varying degrees of validity as “spatial” tasks – see the general discussion) including the place task in the Morris swimming pool.

The Morris swimming pool task was chosen to re-examine the effects of retrosplenial lesions on spatial navigation in the present thesis as this ability has been extensively studied using the behaviour of rats in the swimming pool. Further, the Morris swimming pool task is common to both studies that have previously found retrosplenial deficits, and those that have not, thus increasing its suitability for the present thesis.

### **First objective**

To achieve the first objective I compare the effects of selective retrosplenial aspiration lesions with the effects of combined retrosplenial + cingulum bundle aspiration lesions in order to assess the selective contributions of retrosplenial cortex as well as the effects of concomitant cingulum bundle damage on both place and matching-to-place performance in the swimming pool (Chapter Two). This allows me to assess (1) any retrosplenial contribution to place navigation, and (2) what effect concomitant cingulum bundle damage has on spatial performance.

I also compare the effects of selective retrosplenial aspiration lesions in Long-Evans rats, the strain used in studies that report retrosplenial deficits, to Dark Agouti rats, the strain in which no retrosplenial deficit has been reported (Chapter Two). This experiment stems from a preliminary comparison of place task latencies from studies using these two strains suggesting a possible strain effect influencing the results of retrosplenial lesions. It can be predicted that if retrosplenial aspiration lesions (the method used in studies that find retrosplenial deficits) in Dark Agouti rats (the strain in which retrosplenial deficits are not found) fail to produce spatial impairments on place task performance, then the results support the idea of a strain effect as the source of the

retrosplenial debate; if they fail to disrupt place task performance then some other factor is contributing to the contradictory reports in the literature.

Given the connections of retrosplenial cortex with motor, sensory, and visual association areas, I also investigate the possibility that nonspatial impairments are the source of any behavioural deficits following retrosplenial lesions by assessing the effects of pretraining on swimming pool task performance, monitoring nonspatial learning errors, and by testing the visual acuity of retrosplenial subjects (Chapter Two).

### **Second objective**

To achieve the second objective of this thesis, I assess the effects of NMDA retrosplenial lesions (the lesion used in studies that typically fail to find retrosplenial deficits) in Long-Evans rats (the strain used in studies that typically find retrosplenial deficits) (Chapter Three). If the retrosplenial subjects are impaired, it provides conclusive evidence that (1) retrosplenial cortex is involved in spatial behaviour and (2) there is something abnormal about the Dark Agouti strain as damage to a structure in this strain that by all other accounts should impair spatial behaviour, fails to do so. Further, as the experiment in Chapter One does not directly test the cingulum bundle contribution to spatial navigation I also examine the effects of selective surgical knife-cut lesions to this structure.

Finally, the two main objectives of this thesis, (1) that of retrosplenial involvement in spatial navigation, and (2) an explanation of previous debate in the retrosplenial literature, are addressed in a discussion of the results obtained from this thesis in relationship to the contradictory sets of studies concerning the retrosplenial role

spatial navigation (Chapter Four). This discussion highlights the powerful influences of strain and task revealed by the present work and the importance of implications these influences may have in the study of brain-behaviour relationships.



## CHAPTER TWO\*

### **Impaired Spatial Performance in Rats with Retrosplenial Lesions: Importance of the Spatial Problem and the Rat Strain in Identifying Lesion Effects in a Swimming Pool.**

#### **ABSTRACT**

Behavioural, electrophysiological, and anatomical evidence suggests that retrosplenial (RS) cortex (areas RSA and RSG) plays a role in spatial navigation. This conclusion has been questioned in recent work suggesting that it is damage to the underlying cingulum bundle (CG) (areas CG and IG), and not RS, that disrupts spatial place learning (see Aggleton *et al.*, 2000).

I revisited this issue by comparing Long-Evans rats, the strain used in studies that report RS deficits, to Dark Agouti rats, the strain in which no RS deficit has been reported. Rat groups with RS, RS+CG, or no lesion were tested on a place task in a swimming pool, a test of non-spatial and spatial learning, and a matching-to-place task, a relatively selective test of spatial learning. Long-Evans rats given RS and RS+CG lesions, either before or after training on the two tasks, were impaired on both tasks, a deficit not due to impaired visual acuity. Control Dark Agouti rats and RS Dark Agouti rats although not different on the place task, were both significantly impaired relative to Long-Evans rats. The RS Dark Agouti group, however, was also impaired on the matching-to-place task.

Thus, I show that RS cortex is part of an extended neural circuit involved in spatial behaviour in both Long-Evans and Dark Agouti rats, but its role in the place task may be masked by an innate non-spatial deficit in Dark Agouti rats. The results are

discussed in relation to the importance of assessing spatial learning with appropriate spatial tests, the problems of interpretation posed by rat strain differences, and the role of retrosplenial cortex in spatial behaviour.

\* This chapter is modified from a paper published in *The Journal of Neuroscience* 2002 Feb 1;22(3):1155-64.

## INTRODUCTION

Evidence suggests that retrosplenial (RS) cortex (areas RSA and RSG) plays a role in spatial behavior. Magnetic Resonance Imaging studies show that there is RS activation during spatial problem solving (Mesulam *et al.*, 2001) and that damage to RS cortex results in impaired spatial problem solving (Maguire, 2001). Behavioral studies have also shown impairments in a variety of spatial navigation tasks following RS lesions (Pohl, 1973; DeRenzi, 1982; Pandya & Yeterian, 1984; Sutherland *et al.*, 1988; Kolb, Buhrmann, McDonald, & Sutherland, 1994; Wozniak *et al.*, 1996; Ennaceur, Neave, & Aggleton, 1997; Maaswinkel, Jarrard, & Wishaw, 1999; Cooper & Mizumori, 2001; Wishaw *et al.*, 2001). Single cell recording studies in freely moving animals demonstrate RS cortex cells are responsive to an animal's orientation, its spatial location, and spatial movements (Chen *et al.*, 1994a; Chen *et al.*, 1994b; Cho & Sharp, 2001). Anatomical studies indicate that there are reciprocal connections between RS cortex and neocortex and between RS cortex and a number of structures in the hippocampal formation including the subiculum, the entorhinal and perirhinal cortices and area CA3 of the hippocampus proper (Vogt & Miller, 1983; Pakhomova & Akopian, 1985; Wyss & Van Groen, 1992). Taken together, these studies support a role for RS in bridging neocortical and limbic structures involved in spatial navigation. Thus damage to RS may result in spatial impairments by way of a disconnection (Geschwind, 1965).

The cingulum bundle (CG), lying directly beneath the RS, has also been linked anatomically to the hippocampal formation as part of the Papez circuit (Papez, 1937). Given contemporary evidence that the hippocampal formation has spatial functions, this pathway may also be involved in spatial behaviour. Recent lesion studies have supported

this suggestion (Neave *et al.*, 1997; Warburton *et al.*, 1998; Aggleton *et al.*, 2000).

Indeed, these same studies suggest that it is only the CG and not the RS that has spatial functions. The authors of these studies have proposed that the spatial place learning deficits observed in previous lesion studies resulted from inadvertent damage to the underlying CG accompanying an RS lesion and not from damage to RS itself.

There are three differences between those studies that report that cingulate cortex has spatial functions (Sutherland *et al.*, 1988; Palmer *et al.*, 1993; Whishaw *et al.*, 2001) and those studies that fail to confirm this (Warburton *et al.*, 1998; Aggleton *et al.*, 2000). First, studies reporting no deficit used cell specific neurotoxic lesions that were somewhat smaller than the suction ablations used in studies reporting deficits. Thus, differences in cell vs. fibre damage and/or lesion size may have contributed to the difference in experimental findings. This explanation is unlikely to account for contradictory claims as crossed suction and neurotoxic lesions have been shown to impair spatial performance (Sutherland & Hoising, 1993). Second, studies reporting no deficit used the swimming pool place task in which a rat learns to swim to a single location, whereas studies reporting a deficit used both the place task and a matching-to-place task, in which a rat learns a number of place locations. The former task is sensitive to both spatial and non-spatial deficits (Cain & Saucier, 1996) whereas the latter task is a more selectively spatial task (Whishaw, 1985a). Third, the studies failing to report RS deficits on spatial tasks used the Dark Agouti rat strain, while studies that report RS deficits use the Long-Evans rat strain. An examination of the acquisition curves produced by the different rat strains in the two sets of studies suggest that the Long-Evans rat strain displays superior spatial learning to Dark Agouti rats. Before the idea that the RS has

spatial functions is dismissed, the possibility that task and/or strain differences is responsible for the difference in experimental results must be examined.

Our objective in the present study is to revisit the role of RS in spatial navigation by: (1) comparing the performance of rats with selective suction lesions of the RS to the performance of rats with suction lesions of both RS and CB, (2) assessing the performance of the animals on the place task and the matching-to-place task, and (3) comparing the effects of the lesions on the place task and the matching-to-place task in both Long-Evans and Dark Agouti rat strains.

## MATERIALS AND METHODS

### Subjects

Fifty-four male Long-Evans rats (University of Lethbridge vivarium) approximately 90 days old, weighing between 260-490g and fifteen male Dark Agouti rats (Bantin & Kingman Universal, Fremont, CA) approximately 90 days old, weighing between 190-230g were used in the experiments. For all experiments, subjects were housed in groups of four or five individuals in hanging wire mesh cages. Room temperature was maintained at 20 – 21°C and lighting was on a 12/12 h light/dark cycle (08:00-20:00). Food and water were provided *ad lib*. The subjects either received a retrosplenial cortex suction lesion, a combined retrosplenial cortex and cingulum bundle suction lesion, or no lesion.

## **Surgery**

For all experiments the rats were anaesthetized with sodium pentobarbital (58.5 mg/kg). The cortex was exposed by removing a long piece of skull 2 mm wide either side of the midline, such that a strip of bone approximately 2 mm wide remained over the sagittal sinus. The dura was incised with a No. 11 scalpel. For the retrosplenial cortex lesions, the pia matter was wiped away along with the blood vessels and using suction, the superficial grey matter was gently removed. The lesion did not penetrate to the underlying white matter, the cingulum bundle, or the underlying hippocampus. For the combined retrosplenial cortex and cingulum bundle lesions the ablation included all of the grey matter, and when the underlying white matter was visualized, the dorsally protruding cingulum bundle was removed. The lesion did not include the corpus callosum or hippocampus. Following homeostasis, the skin was sutured.

## **Histology**

At the completion of the experiments, the rats were anaesthetized and perfused intracardially with 0.9% buffered saline followed by 4% paraformaldehyde (PFA) and 14% saturated picric acid (PA) in 0.1 M  $\text{PO}_4$  buffer (pH 6.9). The brains were weighed and stored in the PFA/PA solution for at least 48 h. The brains were then cut at 50  $\mu\text{m}$  on a Vibratome (TPI Inc, St. Louis, MO). Every tenth section was mounted and stained with cresyl violet.

### **Swimming Pool Apparatus**

The swimming pool was located in a test room (287 cm wide x 533 cm long x 244 cm high) in which many cues, including counters, cupboards, posters, etc., were present. A 156-cm diameter and 46-cm high, round white swimming pool positioned 14 cm above the floor, was filled to a depth of 25 cm with 21-22°C water that was made opaque by the addition of 750 cm<sup>3</sup> of powdered milk (Sutherland, Wishaw, & Kolb, 1983). A clear Plexiglas platform with an 11 cm<sup>2</sup> top could be placed in the pool so that the top of the platform was located 1 cm below the surface of the water, where it was not visible to a viewer on the surface of the water. The surface of the platform was serrated so that the rats could obtain purchase as they climbed onto it. The performance of the animals in the swimming pool was tracked using a videocamera/computer based tracking system (San Diego Instruments) that plots the rats swimming latency, swim trajectory, swimming distance, swimming accuracy, and swimming heading. The results were analysed using Analysis of Variance for repeated measures (Winer, 1962).

### **Place Task**

Animals were tested two trials per day for ten consecutive days, with the platform always located in the centre of the SW quadrant of the swimming pool (Morris *et al.*, 1982). A trial consisted of placing a rat by hand into the water, facing the wall of the pool, at one of four starting positions (north, south, east and west) around the perimeter of the pool. The four different start positions were distributed equally among all the subjects on each trial, with the order of start positions for any given subject occurring in a random fashion. If on a particular trial a rat found the platform, it was permitted to

remain on the platform for 10 s. If after 90 sec the rat failed to find the platform, it was then guided to the platform and permitted to remain there for 10 s. At the end of the trial the rat was returned to a holding cage, and approximately 10 to 20 min elapsed before beginning the next trial. After two trials the animals were returned to their home cages and the same procedure was repeated the next day. Measures of swim latency (time to find and mount the escape platform), swim distance, and swimming error were recorded. Swimming error was measured as the inability of a rat to swim in a relatively direct path from the start position to the location of the hidden platform, (Whishaw, 1985b). A correct score (assigned a value of 0) was obtained when the subject swam directly to the platform while remaining within an 18 cm wide corridor, extending from the start location to the platform. Any deviation from a direct swim in a relatively straight line within the corridor resulted in an incorrect score (given a value of 1).

### **Probe Trial**

On the eleventh day of testing the rats were given a probe trial (Sutherland *et al.*, 1983). For the probe trial the platform was removed from the tank and the animal was allowed to swim for 60 s. Probe trials were analysed using a preference analysis (Brown, Bardo, Mace, Phillips, & Kraemer, 2000). The quadrant in which the platform had been located during previous trials was designated as the target quadrant (*T*). The swim times in the remaining three quadrants (*A*, *B*, *C*) were then subtracted from the swim time in the target quadrant and the resultant scores were added and their average derived according to the following formula: Probe Preference score =  $((T-A) + (T-B) + (T-C))/3$ .



Swimming error during the probe trial was measured as the inability of a rat to swim in a relatively direct path from the start position to the now vacant location of the hidden platform, which was removed for the probe trial (Whishaw, 1985b). A correct score (assigned a value of 0) was obtained when the subject swam directly to the platform while remaining within an 18 cm wide corridor, extending from the start location to the platform. Any deviation from a direct swim in a relatively straight line within the corridor resulted in an incorrect score (given a value of 1).

### **Matching-to-Place Task**

Animals were tested two trials per day for 5 consecutive days, with the platform moving to a new location each day (Whishaw, 1985a). The starting position for a given subject remained the same for both trials on a given day. Again the four start positions occurred in a random order for a given animal and were equally distributed among the subjects. The rats were placed into the pool in the same manner as for the place task. During the matching-to-place task, however, the rats were required to swim until they found the platform, where they remained for 10 s, and were then placed in a holding cage for 20 s before beginning trial 2.

### **Visual Acuity Gratings Test**

Long-Evans control rats ( $n=3$ ), Long-Evans retrosplenial rats ( $n=6$ ), and Dark Agouti control rats ( $n=4$ ) were tested in a water based Y-maze where the correct side (side containing the escape platform) was cued by the presence of black and white gratings (Prusky, West, & Douglas, 2000). The animals were tested at consecutively

higher spatial frequencies of the gratings until they failed to meet a criterion of 80% correct choices.

## **PROCEDURES**

Three experiments were conducted.

### **RS Lesions vs. RS+CG Lesions**

Naïve Long-Evans rats were given either a RS suction lesion (n=8) or a RS+CG suction lesion (n=9) and compared with naïve Long-Evans control rats (n=10) on the place task, the probe trial, and the matching to place task.

### **Pre-training on the place and matching-to-place tasks**

Two groups of animals, a Long-Evans control group (n=11) and a Long-Evans RS group (n=9), were used to assess the contributions of possible non-spatial impairments that may result from RS surgery. The groups were trained on the place task, given the probe trial, and trained on the matching-to-place task prior to RS surgery and then the same training was given following surgery.

### **Long-Evans and Dark Agouti Strain Comparison**

Three groups of animals, Dark Agouti RS rats (n=6), Dark Agouti control rats (n=9), and Long-Evans control rats (n=6), were used to compare strain differences on the place task, the probe trial, and the matching-to-place task. Non-spatial errors were also

monitored during the place task (Saucier *et al.*, 1996). These behaviors included diving behavior (diving below the surface of the water during a trial), floating (periods of no swimming lasting three seconds or greater), platform deflections (failing to detect the platform upon contact), mounting error (a delay of one second or greater in mounting the platform upon contact), and jumping (jumping off the escape platform). Each instance of any non-spatial error was given a score of 1; non-spatial scores were summed across all errors for each group and analyzed using an ANOVA.

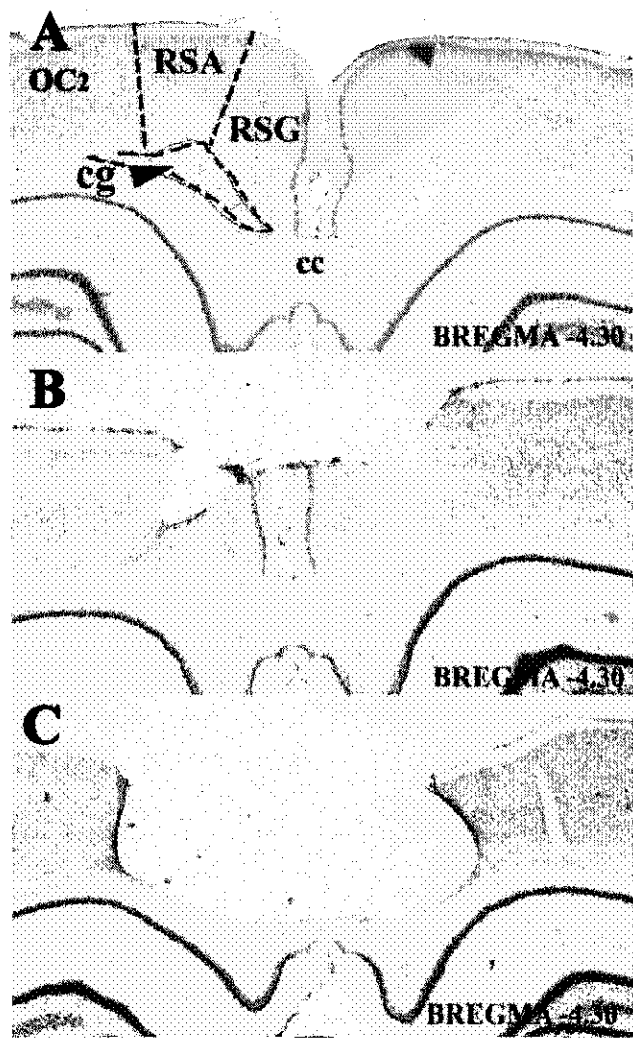
## RESULTS

### **Histological results**

The RS lesions were not as extensive as typical suction ablation lesions of this area (Sutherland *et al.*, 1988; Whishaw *et al.*, 2001). The lesions were, however, selective to posterior cingulate cortex with no apparent damage to the underlying cingulum bundle, corpus callosum or hippocampus, as illustrated in Fig. 2.1A & Fig. 2.1B.

The combined RS + CG lesions were more extensive in the removal of retrosplenial cortex yet still resulted in no apparent damage to the underlying hippocampus (Fig. 2.1C).

*Figure 2.1.* Photomicrographs in coronal view (approx. Bregma  $-4.30$ ) of (A) a representative control rat, (B) a representative retrosplenial rat, and (C) a representative retrosplenial + cingulum bundle rat.



### Experiment: RS Lesions vs. RS+CG Lesions.

#### Place Task

The control rats showed a rapid decrease in latency to find the platform, such that by the fifth trial, they were performing near an asymptotic level of accuracy (Fig. 2.2). The RS and the RS+CG groups also demonstrated an improved performance in reaching the hidden escape platform, although, both groups were impaired relative to controls. As neither the RS nor the RS+CG groups appeared to be performing at asymptotic levels after 10 trials, all the groups were given a further ten trials to the same location. A repeated measures (1 within, 1 between) ANOVA for the measure of latency showed a significant group difference ( $F(2,24) = 14.842, p < 0.05$ ), a significant trial effect ( $F(19,456) = 23.044, p < 0.05$ ), and a significant group x trial interaction ( $F(38,456) = 2.288, p < 0.05$ ). A Student-Newman-Keuls (SNK) posthoc test ( $p < 0.05$ ) gave significant group differences: control < RS, control < RS+CG, and RS = RS+CG. A repeated measures (1 within, 1 between) ANOVA for swim distance reflected the analysis of latency with a significant group effect ( $F(2,24) = 18.658, p < 0.05$ ), a significant trial effect ( $F(19,456) = 18.785, p < 0.05$ ), and a significant group x trial interaction ( $F(19,456) = 2.337, p < 0.05$ ). A SNK post-hoc test ( $p < 0.05$ ) showed that the two experimental groups were both significantly different from the control group, but not from each other: control < RS = RS+CG. The control subjects also made fewer swimming errors en route to the platform. A repeated measures (1 within, 1 between) ANOVA for swimming error showed a significant group difference ( $F(2,24) = 13.127, p < 0.05$ ) with a SNK post-hoc test showing the differences to be: control < RS = RS+CG.

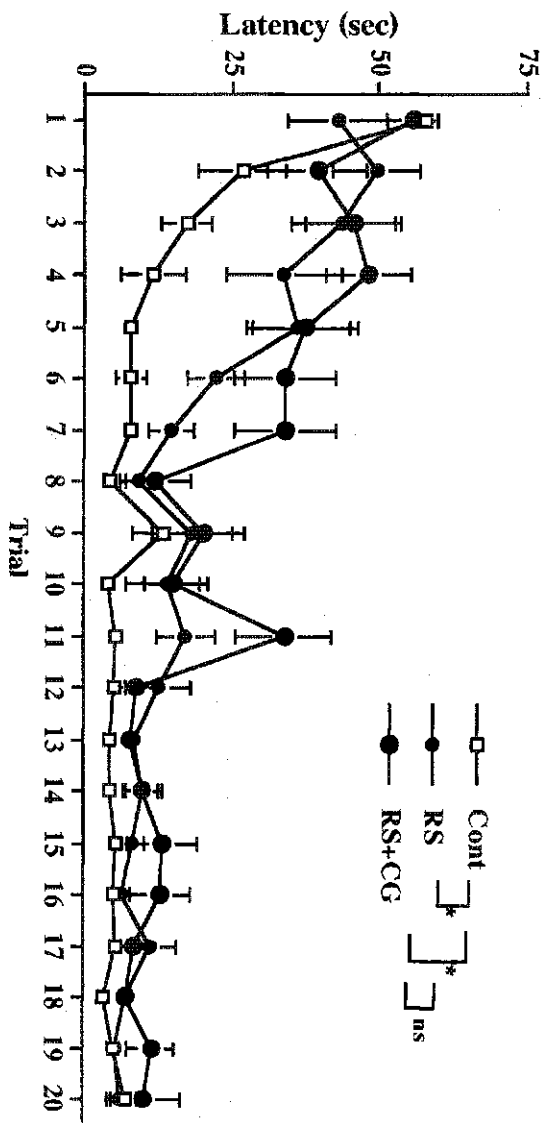
The average swimming speed (swim distance/latency) for each group of rats was also compared to rule out the possibility that the longer latencies for the experimental groups were the result of a simple motor deficit affecting swimming. A repeated measures (1 within, 1 between) ANOVA for swimming speed showed no significant difference between any of the groups (control mean = 35.978 cm/s SE = .614, RS mean = 36.732 cm/s SE = .461, RS+CG mean = 39.226 cm/s SE = .490;  $F(2,24) = 1.869, p > 0.05$ ).

#### **Probe Test**

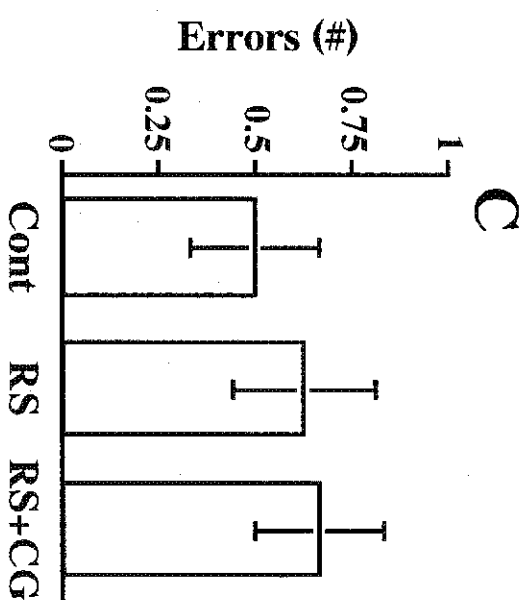
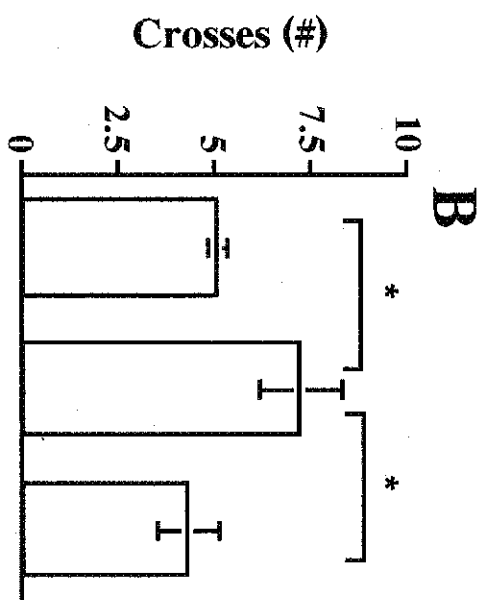
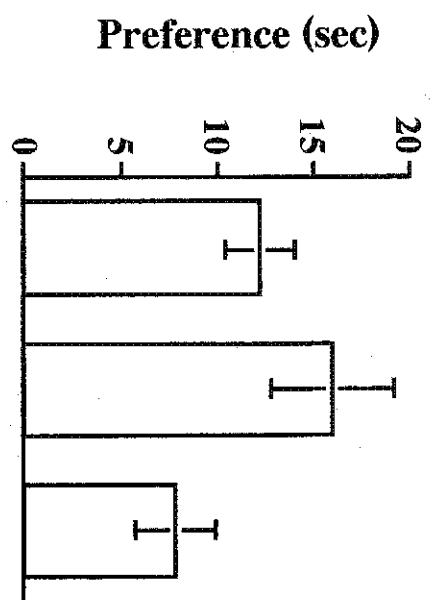
An ANOVA for the target quadrant preference measure on the probe trial (Fig. 2.3A) showed no significant group differences. There was, however, a group effect for the number of target crossings ( $F(2,24) = 4.167, p < 0.05$ ) (Fig. 2.3B). A SNK posthoc test revealed the group differences as: RS > RS+CG = control. That the RS group performed more target crossings is somewhat surprising, but not entirely unexpected. Brain damaged subjects have previously been shown to spend significant amounts of time in the target quadrant on a probe trial (Whishaw & Jarrard, 1995). Furthermore, it is possible that a strategy circling in the correct quadrant will inadvertently produce elevated scores on the measure of target crossings. Thus, in the context of the other behavioural measures, it is more likely that the elevated target crossing scores are the result of a search strategy than an enhancement of spatial learning. There were no significant group differences for the number of direct swimming errors (Fig. 2.3C).

**Figure 2.2.** Latency (mean and S.E.) per trial by control, retrosplenial (RS), and retrosplenial + cingulum bundle (RS+CG) rats over 20 trials on a place task in a swimming pool.

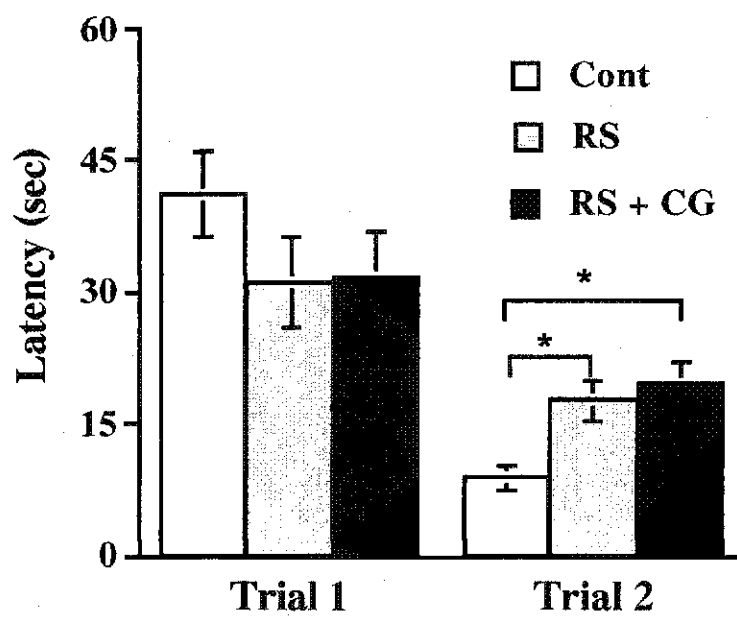




*Figure 2.3.* Mean and S.E. of (A) the spatial preference score – time spent in the target quadrant relative to the other three quadrants (0 s = no preference), (B) the number of passes over the exact location of the hidden platform and (C) the number of errors made in swimming directly to the target, on a 60 sec probe trial administered at the end of the place task to control, retrosplenial (RS), and retrosplenial + cingulum bundle (RS+CG) rats.



*Figure 2.4.* Latency (mean and S.E.) by control, retrosplenial (RS), and retrosplenial + cingulum bundle (RS+CG) rats over two trials averaged across platform locations on a matching-to-place task in the swimming pool.



### **Matching-to-place Task**

Optimal performance on the matching-to-place task is characterized by the ability of a subject to learn the new location of the hidden platform in one trial. This is demonstrated behaviourally in normal subjects by elevated Trial 1 latencies (an indication of having learned and searching out the previous days' location of the hidden platform) followed by significantly reduced Trial 2 latencies (an indication of having learned the new platform location). A repeated measures (2 within, 1 between) ANOVA for the measure of latency on the matching to place task showed no significant group effect, but did show a significant effect of trial ( $F(1,24) = 45.291, p < 0.05$ ), and a significant group x trial interaction ( $F(2,24) = 5.615, p < 0.05$ ). These findings of no overall group effect accompanied by a trial effect and group x trial interaction prompted a further analysis of the group x trial interaction. A repeated measures (1 within, 1 between) ANOVA for the Trial 1 latencies showed no significant group differences (Fig. 2.4). A repeated measures (1 within, 1 between) ANOVA for the Trial 2 latencies however, showed a significant group difference ( $F(2,24) = 8.684, p < 0.05$ ) (Fig. 2.4), with an SNK posthoc test showing the group differences on trial 2 of the matching-to-place task to be: control < RS = RS+CG. These results demonstrate superior one trial learning for a new platform location by the Long-Evans control group in the matching-to-place task.

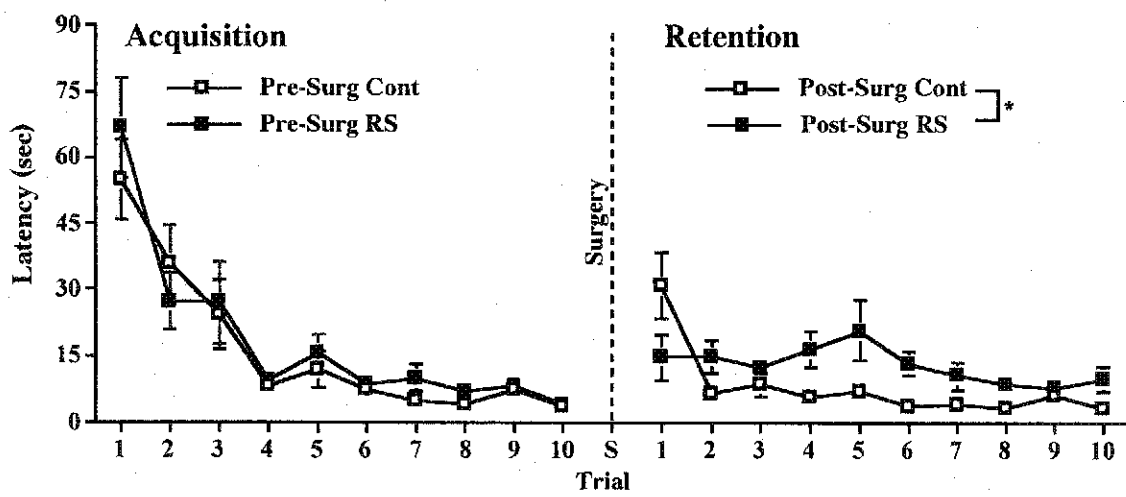
## Pre-training in the swimming pool and RS lesions

### Place Task

A repeated measures (2 within, 1 between) ANOVA for latency over the two testing phases showed a significant group effect ( $F(1,18) = 5.215, p < 0.05$ ) with Long-Evans control < Long-Evans-RS, but no group x testing phase or group x trial interactions; it did show however, a significant group x trial x testing phase interaction ( $F(9,162) = 1.932, p < 0.05$ ). The lack of a significant group x testing phase interaction is due to the fact that both groups show improvement in latencies following surgery. This is most likely the result of the carry over effects for the non-spatial components of the swimming pool task and should in no manner suggest a beneficial effect of surgery on the place task. It does suggest however, that the RS lesion does not disrupt learned non-spatial components of the swimming pool task. Evidence for this can be seen in latency scores on the first two trials following surgery (Fig. 2.5 – Retention) where the Trial 1 – Trial 2 performance of the control group and the RS group is very similar to the Trial 1 – Trial 2 patterns these groups display during the matching-to-place task. In other words, even after the 10 day interval between testing, the LE control animals still display spatial memory for the previous platform location on the first trial of post-surgery testing and are quickly able to learn the new location whereas the Long-Evans-RS animals show no indication of memory for the old location on the first trial nor any improvement to the new location on subsequent trials. Thus, there appears to be an important difference between the groups that is masked by the carry over or savings issues that accompany a within subject experimental design. The significant group effect and the significant group x trial x testing phase interaction also support this idea and suggest further

*Figure 2.5.* Latency (mean and S.E.) per trial by control and retrosplenial (RS) rats, over 10 trials on a place task in a swimming pool both prior to surgery (Acquisition) and following surgery (Retention). The high control latency Trial 1 score on Retention reflects their retention of the last matching-to-place trial.





individual ANOVA's of pre-surgery performance and post-surgery performance to be appropriate.

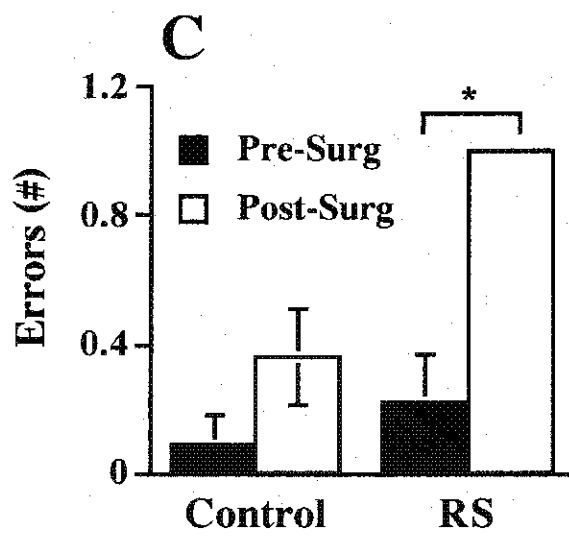
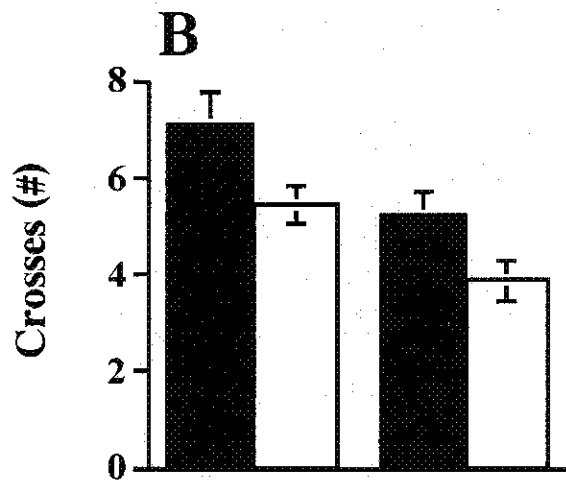
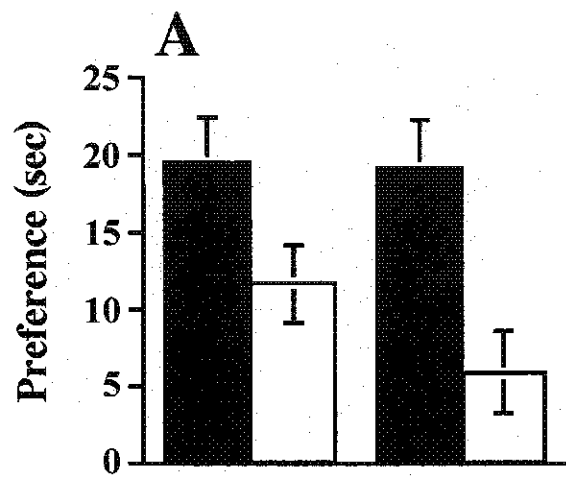
When considered alone, the pre-surgery performance on the place task was identical between the Long-Evans control group and the Long-Evans-RS group (Fig. 2.5). A repeated measures (1 within, 1 between) ANOVA for the swim latencies showed a significant trial effect ( $F(9,162) = 23.548, p < 0.05$ ), but no group effect nor group x trial interaction, as would be expected. Post-surgery, however, the performance of the Long-Evans control group was superior to that of the Long-Evans-RS group (Fig. 2.5). A repeated measures (1 within, 1 between) ANOVA for latency on the post-surgery place task showed a significant group effect ( $F(1,18) = 9.735, p < 0.05$ ), a significant trial effect ( $F(9,162) = 4.909, p < 0.05$ ), and a significant group x trial interaction ( $F(9,162) = 3.300, p < 0.05$ ).

The measure of swimming error supported the finding that the Long-Evans-RS group was impaired following surgery. A repeated measures (2 within, 1 between) ANOVA for swimming error showed a significant group difference ( $F(1,18) = 16.947, p < 0.05$ ) and a significant group x testing phase interaction ( $F(1,18) = 5.650, p < 0.05$ ). Further analysis showed no group differences during pre-surgery testing but did show a significant group effect for post-surgery testing ( $F(1,18) = 17.056, p < 0.05$ ).

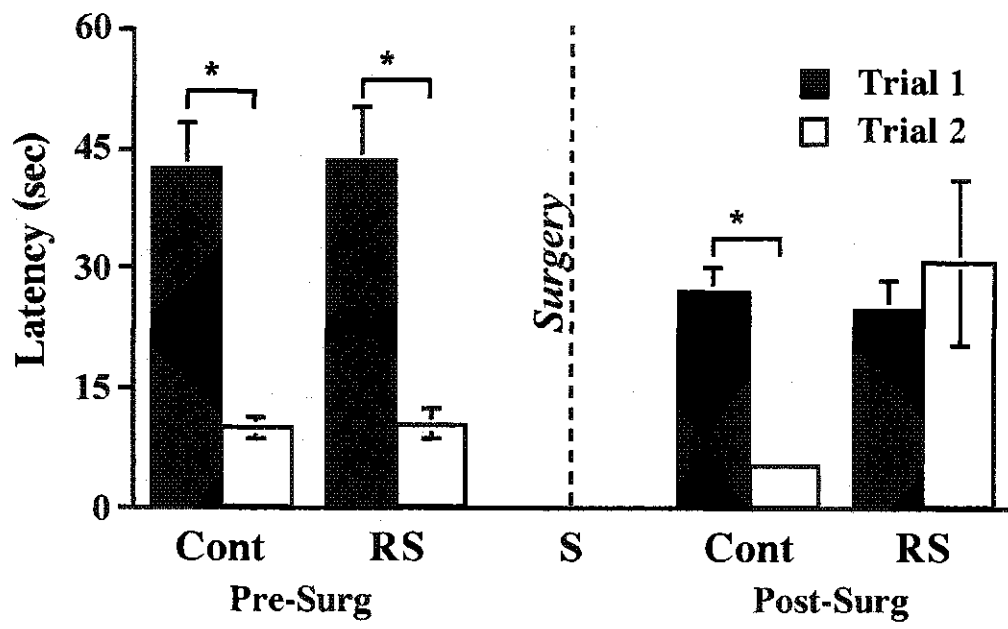
### **Probe Test**

A repeated measures (1 within, 1 between) ANOVA failed to show a group x testing phase interaction for the spatial preference score (Fig. 2.6A) and for the number of platform crossings (Fig. 2.6B), but did show a significant group x testing phase

**Figure 2.6.** Pre and post surgery mean and S.E. of (A) the spatial preference score – time spent in the target quadrant relative to the other three quadrants (0 s = no preference), (B) the number of passes over the exact location of the hidden platform and (C) the number of errors made in swimming directly to the target, on a 60 sec probe trial administered at the end of the place task to control and retrosplenial (RS) rats.



*Figure 2.7.* Pre and post surgery latency (mean and S.E.) by control and retrosplenial (RS) rats over two trials averaged across platform locations on a matching-to-place task in the swimming pool.



interaction for swimming errors. A one factor ANOVA showed the significant group x trial interaction to be the result of the Long-Evans – RS group making significantly more direct swimming errors following surgery ( $F(1,16) = 28.000, p < 0.05$ ) (Fig. 2.6C).

### **Matching-to-Place**

Prior to surgery both Long-Evans groups were able to demonstrate one-trial learning on the matching-to-place task equally well (Fig. 2.7). Following surgery, however, the RS group performed much worse on the task. These observations were confirmed by a repeated measures (3 within, 1 between) ANOVA for latency that showed a significant group x trial x testing phase interaction ( $F(1,18) = 4.837, p < 0.05$ ). Further analysis revealed this interaction to be the result of a significant group x trial interaction ( $F(1,18) = 6.627, p < 0.05$ ) during the post-surgery phase of testing as the result of no one trial learning being demonstrated by the Long-Evans-RS group.

## **Long-Evans and Dark Agouti strain comparison**

### **Place Task**

All three groups (Long-Evans control, Dark Agouti control, Dark Agouti-RS lesion) showed some improvement over trials during the place task, however, the Long-Evans control group demonstrated a significantly more rapid decrease in latency to find the hidden platform compared to both the Dark Agouti-RS group *and* the Dark Agouti control group (Fig. 2.8). Performance between the Dark Agouti control and Dark Agouti-RS group was not significantly different. A repeated measures (1 within, 1 between) ANOVA for the measure of latency showed a significant group difference ( $F(2,18) =$

6.549,  $p < 0.05$ ) a significant trial effect ( $F(9,162) = 13.399, p < 0.05$ ), but no significant group x trial interaction. A SNK posthoc test showed the group differences as: Long-Evans < Dark Agouti control = Dark Agouti-RS.

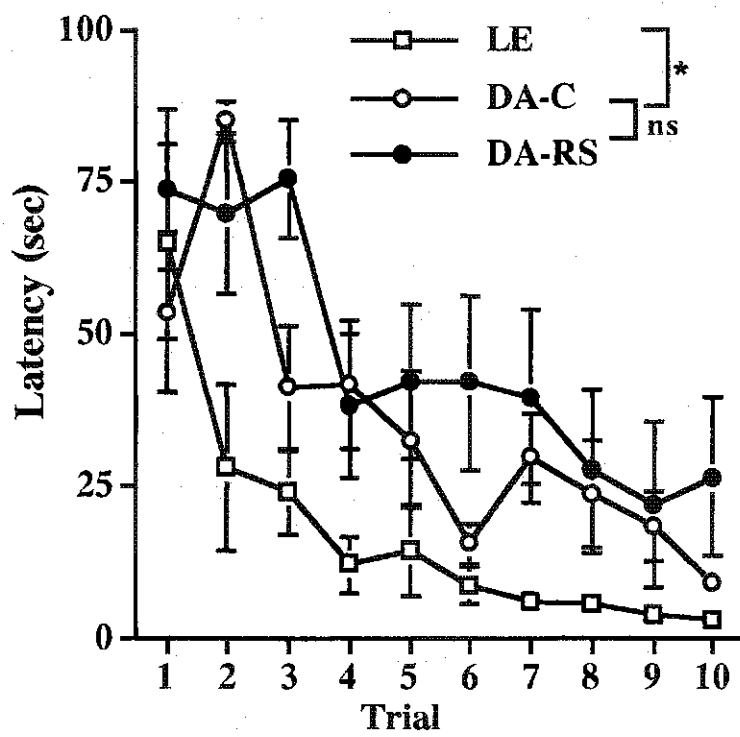
Long-Evans rats also committed significantly fewer swimming errors during the swim trajectory to the platform ( $F(2,18) = 9.247, p < 0.05$ ) with an SNK post-hoc test showing the significant differences to be: Long-Evans < Dark Agouti control = Dark Agouti-RS.

### Probe Test

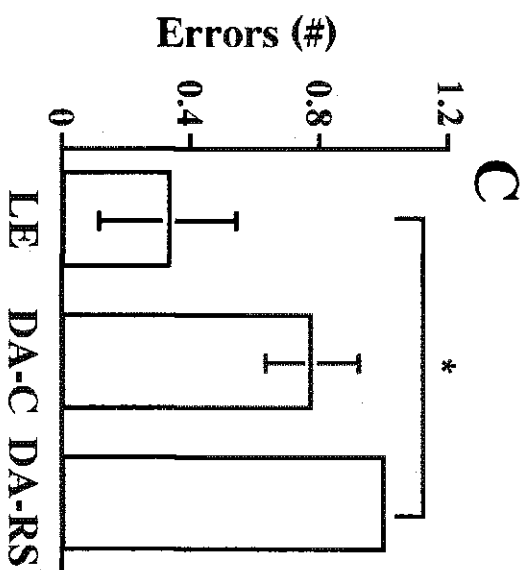
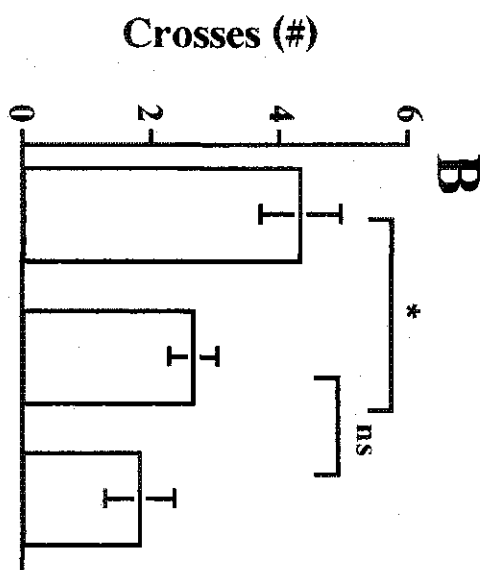
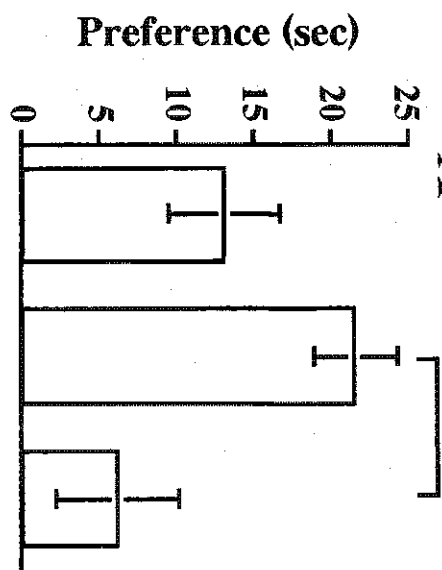
An ANOVA for the target quadrant preference measure on the probe trial (Fig. 2.9A) showed a significant group difference ( $F(2,18) = 5.772, p < 0.05$ ). A SNK posthoc test revealed the group differences as: Dark Agouti control > Dark Agouti-RS. Significant group differences were also observed on the measure of target crossings ( $F(2,18) = 5.860, p < 0.05$ ) (Fig. 2.10B); a SNK posthoc test revealed the differences as: Long-Evans > Dark Agouti control = Dark Agouti-RS. There was a significant group effect for direct swim errors as well ( $F(2,18) = 4.352, p < 0.05$ ) (Fig. 2.9C); a SNK posthoc test showed the differences to be: LE < Dark Agouti-RS. The performance of the Dark Agouti control subjects on the probe test is of interest as this group demonstrates a strong preference for the correct quadrant, yet scores significantly worse than the Long-Evans group on the number of target crossings. These results suggest that although the Dark Agouti rats have learned something about the general location of the platform in the pool, they have not learned the exact location.



*Figure 2.8.* Latency (mean and S.E.) per trial by Long-Evans control (LE), Dark Agouti control (DA-C), and Dark Agouti retrosplenic (DA-RS) rats over 10 trials on a place task in a swimming pool.



**Figure 2.9.** Mean and S.E. of (A) the spatial preference score – time spent in the target quadrant relative to the other three quadrants (0 s = no preference), (B) the number of passes over the exact location of the hidden platform and (C) the number of errors made in swimming directly to the target, on a 60 sec probe trial administered at the end of the place task to Long-Evans Hooded control (LEH), Dark Agouti control (DA-C), and Dark Agouti retrosplenial (DA-RS) rats.



### **Matching-to-Place**

Only the Long-Evans group and the Dark Agouti control group demonstrated the ability to learn the new platform location in one trial (Fig. 2.10). Performance by the Dark Agouti-RS group was impaired relative to the other groups. A repeated measures (2 within, 1 between) ANOVA for the measure of latency showed no significant group differences overall, but did show a significant trial effect ( $F(1,18) = 40.975, p < 0.05$ ), and a significant group x trial interaction ( $F(2,18) = 8.261, p < 0.05$ ).

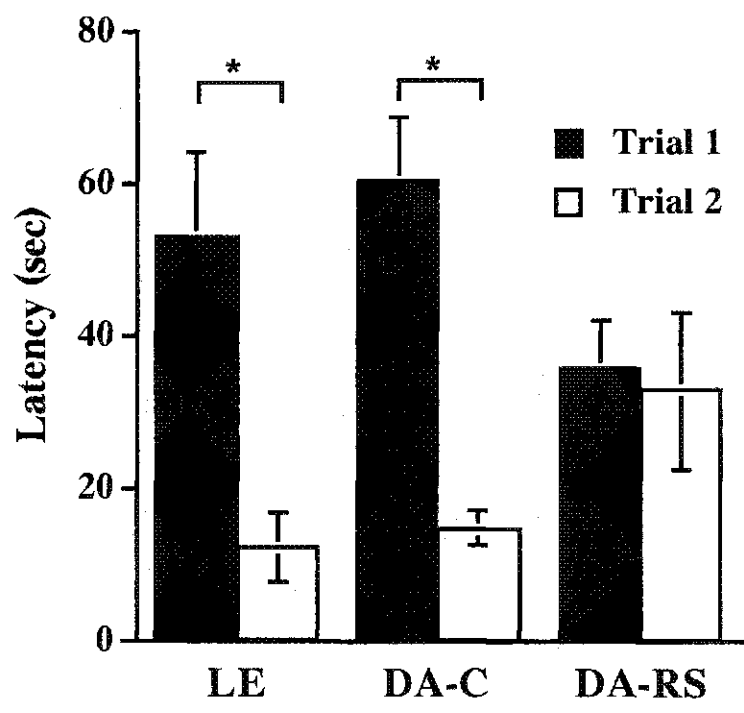
### **Non-Spatial Errors in the Place Task**

The Long-Evans group displayed very few non-spatial errors during the place task. Errors committed by the Long-Evans group were restricted to deflections and floating. Both the Dark Agouti control and the Dark Agouti-RS groups displayed non-spatial errors of every category. An ANOVA for the non-spatial error scores showed a significant group effect (Long-Evans Mean = 0.833 SE .543, Dark Agouti control Mean = 3.889 SE .696, Dark Agouti – RS Mean = 4.667 SE .843;  $F(2,18) = 6.273, p < 0.05$ ). A SNK posthoc test showed the group differences to be: Long-Evans < Dark Agouti control = Dark Agouti-RS.

### **Visual Acuity**

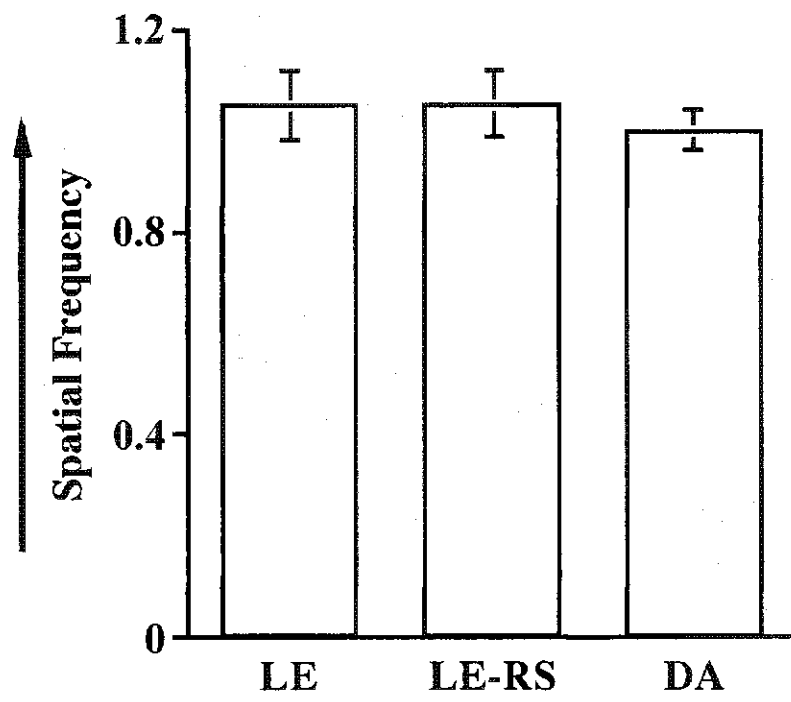
The gratings test showed that the Long-Evans control and RS groups had equal and normal visual acuity ( $F(1,7) = 1.185E -4, p = 0.9916$ ) and that the visual acuity of Long-Evans and Dark Agouti rats was also not different ( $F(1,5) = .457, p = 0.529$ ) (Fig. 2.11).

*Figure 2.10.* Latency (mean and S.E.) by Long-Evans control (LE), Dark Agouti control (DA-C), and Dark Agouti retrosplenial (DA-RS) rats over two trials averaged across platform locations on a matching-to-place task in the swimming pool.



*Figure 2.11.* Mean and S.E. of the maximum visual acuity (measured in terms of spatial frequency or cycles per degree) demonstrated by Long-Evans (LE) control Long-Evans-retrosplenic (RS), and Dark Agouti control (DA) rats.





## DISCUSSION

A re-examination of the role of the RS in spatial navigation in two swimming pool tasks confirmed that selective lesions limited to this structure impairs spatial behaviour. Both naïve animals and animals that had been pre-trained prior to receiving lesions were impaired in the acquisition/performance of a place task and were also impaired on a matching-to-place task. Concomitant CG damage did not increase the severity of the spatial deficits. Results of other studies (Warburton *et al.*, 1998), suggesting that RS is not involved in spatial behaviour are shown to be due to use of a rat strain in which the spatial impairment is masked by an innate non-spatial impairment and a failure to use a stringent testing method. Thus, the present results are definitive in indicating that RS cortex participates in spatial learning, perhaps via reciprocal anatomical connections between cortical areas and the hippocampal formation (Vogt & Miller, 1983; Pakhomova & Akopian, 1985; Wyss & Van Groen, 1992).

The present study was prompted by two seemingly irreconcilable sets of results concerning the role of RS in spatial learning. The results of one set of studies (Sutherland *et al.*, 1988; Whishaw *et al.*, 2001) suggest that RS is involved in spatial navigation. Rats with suction ablations of RS were impaired in learning the Morris place task (Morris *et al.*, 1982), a task requiring that they find a stationary hidden platform in a swimming pool. The rats were also impaired in the more demanding matching-to-place task that required that they learn to find the platform at a number of new locations, responses that are learned by normal rats in a single trial (Whishaw, 1985b). In the second set of studies, (Warburton *et al.*, 1998), rats received neurotoxic lesions of the RS and were tested in only the place task. The rats are reported to have no impairment in

place learning. In order to explain these strikingly different results, the latter studies also used animals with CG lesions alone, and did find a deficit on the place task with the CG lesion. They suggest, therefore, that the suction ablations used by the former group produced spatial deficits because the lesions included the CG.

In the first portion of the present study we re-examined the claim (Neave *et al.*, 1994; Aggleton *et al.*, 1995; Warburton *et al.*, 1998; Aggleton *et al.*, 2000) that selective RS lesions produce no spatial deficit on the place task. We removed RS alone by stripping the meninges and restricting the suction removal to the superficial grey matter. CG was additionally removed by first removing the grey matter and then removing the most superficial portion of the white matter. Histological analysis confirmed that the desired lesions were achieved. The results of the behavioural tests, showed that both RS and RS + CG lesions produced an impairment in the place task. Although impaired, both groups did show improvement with training, as indicated both by reduced times in locating the platform and heightened searches of the previously correct quadrant of the pool in a probe trial with the platform removed from the pool. The finding that RS lesions did produce a deficit in spatial learning is consistent with the first set of studies (Sutherland *et al.*, 1988; Whishaw *et al.*, 2001), not the second set of studies (Warburton *et al.*, 1998). In addition, the rats with RS lesions were impaired in the matching-to-place task, a result also consistent with the first set of studies. Further, these results strengthen the likelihood of RS being part of a neural circuit mediating spatial learning and memory as the working memory and reference memory impairments observed in the RS group coincide with similar memory impairments observed in other components of this circuit such as the hippocampal formation (Shapiro, 2001).

In order to reconcile the disparate results in these two sets of studies, I examined the possibility that the use of different strains of rats might have been a contributing factor. The first set of studies, and the first experiment of the present study, used Long-Evans rats. The rats used in the second set of studies were of the Dark Agouti strain. Our attention to possible rat strain differences was prompted by the more rapid learning displayed by the Long-Evans as compared to the Dark Agouti rats in the respective studies. When I compared Dark Agouti control rats to Dark Agouti rats with RS lesions on the place task in the present study, I found no difference between the groups, and both were significantly inferior to a Long-Evans control group. That is, I confirmed that Dark Agouti rats with a RS lesion are not impaired, but I also found that the Dark Agouti strain was impaired in learning the place task relative to Long-Evans strain.

Despite the fact that I found that the Dark Agouti rats with RS lesions were not impaired in acquiring the place task relative to Dark Agouti control rats, I did find that the Dark Agouti RS group was impaired relative to the Dark Agouti control group on the matching-to-place task. Thus, I was able to demonstrate that even though rats of this strain with RS lesions were not impaired in simple place acquisition relative to their control group, they were impaired in the more demanding matching-to-place task.

To understand why a rat strain difference could manifest itself in the place task and not in the matching-to-place task, it is important to recognize that neither task is selective for place learning. In order to learn the place task, rats must engage in considerable non-spatial learning (Whishaw, 1985b; Cain & Saucier, 1996). That is, they must learn to swim about the pool in search of an escape route, they must learn to swim away from the wall of the pool, and they must learn that when they encounter the

platform it is the only escape route, etc. Only once they have acquired these procedures are they able to demonstrate place learning. Rats may be impaired in non-spatial learning while still being able to display spatial learning (Cain & Saucier, 1996; Saucier *et al.*, 1996; Cain, 1997; Hoh & Cain, 1997). Thus, an animal that is impaired in non-spatial learning once having acquired the non-spatial procedures during the place task may be less impaired in matching-to-place learning, which requires both the use of those procedures and spatial learning. Thus, I propose that the Dark Agouti rats are impaired in non-spatial learning and this deficit masks the effects of an RS lesion. Nevertheless, once having acquired the non-spatial learning components of the task they are sufficiently skilled in place learning to perform the matching-to-place task, which does reveal a deficit produced by the RS lesion. Our evidence to support this hypothesis comes from the observation of several behaviours that are considered to be non-spatial learning errors, such as jumping, diving, deflections, floating, etc., (Cain & Saucier, 1996) exhibited by the Dark Agouti rats. These behaviours were most prominent during the first few trials of the place task after which they subsided, and very rarely reappeared during the matching-to-place task.

The fact that Dark Agouti rats display a deficit in non-spatial learning raises the possibility that the RS deficits observed on the place task in our study with Long-Evans rats, and previous studies using this strain (Sutherland *et al.*, 1988; Whishaw *et al.*, 2001), may only be the result of a non-spatial impairment. The current study provides four lines of evidence against this possibility. First, the Long-Evans RS group that received pre-surgical training, a procedure that provides non-spatial information (Whishaw, 1985b; Hoh & Cain, 1997) in the swimming pool was still impaired on the place task. Second,

these rats also failed to exhibit behaviours typical of non-spatial impairment (Cain & Saucier, 1996) such as thigmotaxis, failure to detect the escape platform upon contact, jumping off the platform, etc. Third, all groups of rats given an RS lesion, regardless of rat strain, were impaired on matching-to-place performance. Fourth, I examined the visual acuity of control and lesion rats in a visual grating task (Prusky *et al.*, 2000), and found visual acuity was normal. Thus, our lesion of RS did not invade primary visual cortex and so produce a visual impairment.

In the studies by the Aggleton group (Warburton *et al.*, 1998), it is reported that selective CG lesions produced an impairment in place learning. In the present study I tested a group of rats with CG plus RS lesions and found that this combined lesion group displayed an impairment similar in size to that of the RS group. It is possible that both CG and RS lesions produce a place learning deficit, but that possibility was not further examined in the present study.

## CONCLUSION

In conclusion, the results of the present study demonstrate that RS lesions produce a deficit in both the place task and the matching-to-place task, thus confirming that the RS is part of a neural circuit involved in spatial behaviour. The deficit was not secondary to impairments in non-spatial learning, as pre-training on both tasks prior to surgery did not ameliorate the deficit. This study is also the first to demonstrate that an innate impairment carried by a rat strain can mask behavioural deficits produced by a brain lesion. Nevertheless, I demonstrate that by using appropriate testing procedures, it is still

possible to unmask the negative performance displayed by the rat strain thus revealing the effects of the lesion.

## CHAPTER THREE\*

**Impaired place navigation in place and matching-to-place swimming pool tasks follows both retrosplenial cortex lesions and cingulum bundle lesions in rats.**

### ABSTRACT

The retrosplenial (RS) cortex (area 29) and the adjacent cingulum bundle (CG) are components of neural circuits that include the hippocampus. Given the evidence suggesting that the hippocampus plays a central role in spatial navigation, several lines of investigation have examined the possible contributions of these structures to spatial navigation. The combined and/or separate contributions of the structures has been difficult to establish because their close proximity usually results in combined injury following lesions and because there have been conflicting results related to lesion type and strain of rat subjects. The purpose of the study in this chapter was to compare the effects of selective CG damage to selective RS damage on spatial behaviour using selective lesion methods and spatial assessment procedures that are sensitive to CG damage and using Long-Evans rats, a strain that displays superior spatial skills. Rats with cytotoxic n-methyl-d-aspartate (NMDA) RS lesions or surgical CG transection were tested on two spatial tasks in the Morris Water Task; a place learning task and a matching-to-place task. Both the RS and the CG group were impaired on most measures relative to the control group on both the place task and the matching-to-place task. The results are discussed in relation to the anatomical organization of CG and RS projections to the hippocampus and with respect to their possible separate/conjoint contributions to spatial behaviour.

\*This chapter is modified from a paper submitted for publication to *Hippocampus*.



## INTRODUCTION

Over the last decade the relative contributions of retrosplenial (RS) cortex (area 29) and the adjacent cingulum bundle (CG) fibre pathway to spatial navigation in rats have been a subject of debate. There is evidence from RS lesion / inactivation studies to suggest that RS plays an important role in linking many of neocortical and limbic structures involved in spatial navigation (Sutherland, Wishaw, & Kolb, 1988; Kolb & Wishaw, 1991; Sutherland & Hoising, 1993; Cooper, Manka, & Mizumori, 2001; Wishaw, Maaswinkel, Gonzalez, & Kolb, 2001). This evidence is supported by anatomical (Vogt & Miller, 1983; Pakhomova & Akopian, 1985; Wyss & Van Groen, 1992) and electrophysiological evidence (Vogt & Miller, 1983; Pakhomova & Akopian, 1985; Wyss & Van Groen, 1992; Chen, Lin, Barnes, & McNaughton, 1994; Chen, Lin, Green, Barnes, & McNaughton, 1994; Cho & Sharp, 2001; Cooper & Mizumori, 2001) that suggest an RS role in spatial behaviour.

There is also evidence, however, suggesting that damage to CG, which lies just underneath and adjacent to RS, impairs spatial behaviour (Neave, Lloyd, Sahgal, & Aggleton, 1994; Aggleton, Neave, Nagle, & Sahgal, 1995; Warburton, Aggleton, & Muir, 1998). Further, CG is shown to be an important component in linking many of the structures in limbic circuitry (Papez, 1937) that have subsequently been implicated in spatial behaviour (O'Keefe & Nadel, 1978; Morris, Garrud, Rawlins, & O'Keefe, 1982; Sutherland & Rodriguez, 1989; Wishaw, McKenna, & Maaswinkel, 1997) as well as damage to CG is also shown to disrupt normal hippocampal activity (Vanderwolf, Leung, & Stewart, 1985; Kolb & Wishaw, 1991).

A difficulty in interpreting the behavioural studies of RS and CG contributions to spatial behaviour is that lesions are often not selective and/or appropriate assessments of spatial deficits are not made. Indeed, in many of the studies of RS spatial deficits using suction ablation the lesions appear to result in damage to RS, CG, and occasionally very minor damage to the hippocampus (Sutherland *et al.*, 1988; Kolb & Whishaw, 1991; Sutherland & Hoising, 1993; Whishaw *et al.*, 2001). As well, studies using temporary RS inactivation often include both RS and CG (Cooper *et al.*, 2001). A problem arises in that given the evidence of CG spatial deficits it is quite possible that the spatial impairments observed following RS damage may be simply attributed to concomitant CG damage, and not to RS. This argument appears to be supported by studies that fail to find spatial deficits following more selective cytotoxic n-methyl-d-aspartate (NMDA) RS lesions (Neave *et al.*, 1994; Aggleton *et al.*, 1995; Warburton *et al.*, 1998). These studies are at odds with more recent evidence demonstrating similar spatial deficits following both selective RS aspiration lesions and combined RS + CG lesions (Harker & Whishaw, 2002a; Harker & Whishaw, 2002b; Mehan *et al.*, 2002); the effects of selective CG damage however, were not tested in this study. Further, the studies that typically fail to find RS deficits use a rat strain whose usefulness for the study of normal brain-behaviour relationships is seriously questioned (Harker & Whishaw, 2002a; Harker & Whishaw, 2002b; Mehan *et al.*, 2002). Thus an understanding of the relative effects of selective RS and selective CG damage is incomplete at this time as there remains the possibility of a fundamental difference in behavioural the outcomes of aspiration versus cytotoxic lesions, as well as the uncertainty of the CG results obtained using the Dark Agouti rat strain.

The purpose of the present study therefore is to assess the relative effects of RS and CG damage on spatial behaviour in the place task and the matching-to-place task in a swimming pool by using (1) cell-specific NMDA lesions (the lesion method used in studies that have typically failed to find RS deficits); (2) selective surgical CG transections so as to compare the selective effects of CG damage; (3) Long-Evans rats, the strain in which selective RS deficits have been found and which have been demonstrated to be more appropriate for the investigation of normal brain-behaviour relationships.

## MATERIALS AND METHODS

### Subjects

Twenty-two male Long-Evans rats (Charles River) approximately 110 days old, weighing between 440-580g were used in the experiments. Subjects were housed in groups of two individuals in hanging plexiglass cages. Room temperature was maintained at 20 – 21°C and lighting was on a 12/12 h light/dark cycle (08:00-20:00). Food and water were provided *ad lib*. The subjects received either a cytotoxic *N*-methyl-D-aspartate (NMDA) retrosplenial cortex lesion ( $n = 6$ ), a surgical knife cut cingulum bundle lesion ( $n = 6$ ), or no lesion ( $n = 6$ ). To control for any possible effects from cortical damage resulting from the knife cut to the cingulum bundle another group of subjects ( $n = 3$ ) were given cortical knife cuts at the same coordinates as the cingulum bundle group.

## **Surgery**

The rats were anaesthetized with sodium pentobarbital (58.5 mg/kg). Bilateral retrosplenial cortex lesions were made by infusing 0.4  $\mu$ l of 0.09M NMDA (Sigma-Aldrich) at each of the following coordinates relative to Bregma: (i) AP -3.3, L +/-0.7, DV -1.5; (ii) AP -4.3, L +/-0.8, DV -1.0; (iii) AP -5.3, L +/-0.8, DV -1.0; (iv) AP -6.3, L +/-0.9, DV -2.0.

The cingulum bundle knife-cut lesions were made using No.5 surgical tweezers to cut the cingulum bundle bilaterally at the following coordinates: AP -1.6, L +/-0.65 to 1.8, DV -2.7. The cortex was exposed by removing a piece of skull 1 mm wide perpendicular to either side of the midline. Secured to the stereotaxic unit, the tweezers were gently lowered at maximum width (1.15mm) at the desired coordinates, gently pinched together, and then slowly raised approximately 1.8mm and released so as to provide a complete transection of the cingulum bundle while minimizing extraneous cortical damage. The cortical knife cut lesions were made at the same coordinates and in the same manner as those for the cingulum bundle but did not extend deep enough damage the underlying fibre tract. Following homeostasis, the skin was sutured.

## **Histology**

At the completion of the experiments, the rats were anaesthetized and perfused intracardially with 0.9% buffered saline followed by 10% formal saline. The brains were weighed and stored in a 30% sucrose-formalin solution for at least 48 h. The brains were then cut frozen at 50  $\mu$ m. Every third section was mounted and stained with cresyl violet.

### **Swimming Pool Apparatus**

The swimming pool was located in a test room (304 cm wide x 600 cm long x 366 cm high) in which a number of cues, including counters, posters, etc., were present. A 156-cm diameter and 46-cm high, round white swimming pool positioned 30 cm above the floor, was filled to a depth of 30 cm with 21-22°C water that was made opaque by the addition of 750 cm<sup>3</sup> of powdered milk (Sutherland *et al.*, 1983). A round white plastic platform 11 cm in diameter could be placed in the pool so that the top of the platform was located 1 cm below the surface of the water, where it was not visible to a viewer on the surface of the water. The surface of the platform was serrated so that the rats could obtain purchase as they climbed onto it. The performance of the animals in the swimming pool was tracked using a video camera/computer based tracking system (HVS Image) that plots the rats swimming latency, swim trajectory, swimming distance, swimming accuracy, and swimming heading. The results were analysed using Analysis of Variance (ANOVA) for repeated measures (Winer, 1962).

### **Place Task**

Animals were tested two trials per day for ten consecutive days, with the platform always located in the centre of the SW quadrant of the swimming pool (Morris *et al.*, 1982). Because the platform remains in the same location on every trial, this task is thought to be largely a task of reference memory. A trial consisted of placing a rat by hand into the water, facing the wall of the pool, at one of four starting positions (north, south, east and west) around the perimeter of the pool. The four different start positions were distributed equally among all the subjects on each trial, with the order of start

positions for any given subject occurring in a random fashion. If on a particular trial a rat found the platform, it was permitted to remain on the platform for 10 s. If after 90 sec the rat failed to find the platform, it was then guided to the platform and permitted to remain there for 10 s. At the end of the trial the rat was returned to a holding cage, and approximately 10 to 20 min elapsed before beginning the next trial. After two trials the animals were returned to their home cages and the same procedure was repeated the next day.

Latency, path length, and swim trajectory errors were recorded on all place task trials. Swim trajectory errors were measured as the inability of a rat to swim in a relatively direct path from the start position to the location of the hidden platform, which was removed for the probe trial (Whishaw, 1985b). A correct score (assigned a value of 0) was obtained when the subject swam directly to the platform while remaining within an 18 cm wide corridor, extending from the start location to the platform. Swimming outside of the 18 cm corridor resulted in an incorrect score (given a value of 1).

Nonspatial errors were also monitored during the place task (Saucier *et al.*, 1996). Nonspatial learning errors, or rather the lack thereof, provided a measure of procedural learning and memory in the swimming pool task. These behaviours included diving behaviour (diving below the surface of the water during a trial), floating (periods of no swimming lasting three seconds or greater), platform deflections (failing to detect the platform upon contact), mounting error (a delay of one second or greater in mounting the platform upon contact), and jumping (jumping off the escape platform). Each instance of a nonspatial error was given a score of 1; nonspatial scores were summed across all errors for each group and analysed using an ANOVA.

### **Probe Trial**

On the eleventh day of testing the rats were given a probe trial (Sutherland *et al.*, 1983). For the probe trial the platform was removed from the tank and the animal was allowed to swim for 60 s. Probe trials were analysed using a quadrant preference measure (Brown *et al.*, 2000). The quadrant in which the platform had been located during previous trials was designated as the target quadrant (T). The swim times in the remaining three quadrants (A, B, C) were then subtracted from the swim time in the target quadrant and the resultant scores were added and their average derived according to the following formula: Probe Preference score =  $((T-A) + (T-B) + (T-C))/3$ .

Swim trajectory errors and the number of passes made by the subject over the old platform location (referred to as target crossings) were also recorded during the probe trial.

### **Matching-to-Place Task**

This task is relatively more difficult for subjects as it places demands on reference memory, (remembering the location of the platform from the previous day), but also contains a very strong working memory component, (learning and remembering the new location). Animals were tested two trials per day for 5 consecutive days, with the platform moving to a new location each day (Whishaw, 1985a). The starting position for a given subject remained the same for both trials on a given day. Again the four start positions occurred in a random order for a given animal and were equally distributed among the subjects. The rats were placed into the pool in the same manner as for the

place task. During the matching-to-place task, however, the rats were required to swim until they found the platform, where they remained for 10 s, and were then placed in a holding cage for 20 s before beginning trial 2. Latency, path length, and swim trajectory errors were recorded.

## RESULTS

### Histological Results

The RS lesions were not as extensive as typical suction ablation lesions of this area (Sutherland *et al.*, 1988; Whishaw *et al.*, 2001), but appear to be comparable to the suction ablation lesions reported by Harker and Whishaw (Harker & Whishaw, 2002a) as well as to typical NMDA lesions of this area (Aggleton *et al.*, 1995; Warburton *et al.*, 1998). Damage from the lesions was largely restricted to RS with the no apparent damage to the underlying corpus callosum (Fig. 3.1A & Fig. 3.1B).

The CG surgeries resulted in a complete transection of this fibre pathway with limited damage to the overlying cortex (Fig. 3.2A & Fig. 3.2B). Further, the CG damage was made just anterior to RS so as to better selectively measure the effects from damage to this structure.

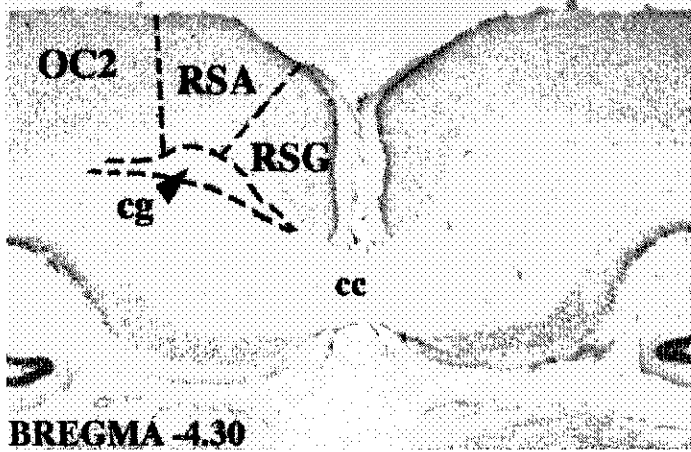
### Behavioural Results

The behaviour of the CG surgical control group was not significantly different than the control group on any of the measures and as such was included with the control group for all statistical analyses.

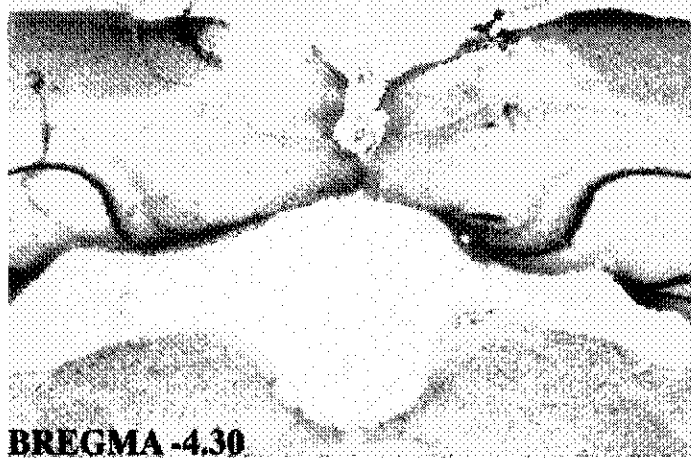


*Figure 3.1.* Photomicrographs in coronal view of a representative control rat (*A*) and a representative NMDA lesioned retrosplenial rat (*B*), (approximately Bregma -4.30). (Abbreviations: retrosplenial cortex (RS); cingulum bundle (CG); visual association cortex (OC2); corpus callosum (cc))

**A**

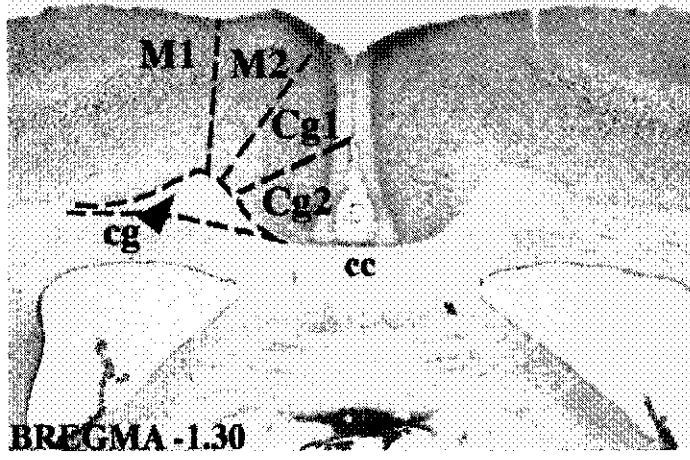


**B**



**Figure 3.2.** Photomicrographs in coronal view of a representative control rat (A) and a representative knife-cut lesioned cingulum bundle rat (B) (approximately Bregma -1.30). Damage to overlying cortex is minimized to the site of the surgical transection. (Abbreviations: anterior cingulate cortex (Cg), cingulum bundle (cg), corpus callosum (cc) motor cortex (M))

**A**



**B**



### **Place Task**

All groups showed a decrease in latency to find the hidden platform in the place task however, the control group required significantly less time than both the RS group and the CG group to learn the platform location (Fig. 3.3A). A repeated measures (one within, one between) ANOVA for the measure of latency showed a significant group effect ( $F(2,19) = 8.840; p < 0.05$ ). A Student-Newman-Keuls (SNK) post hoc test showed the significant group differences to be Control < RS = CG.

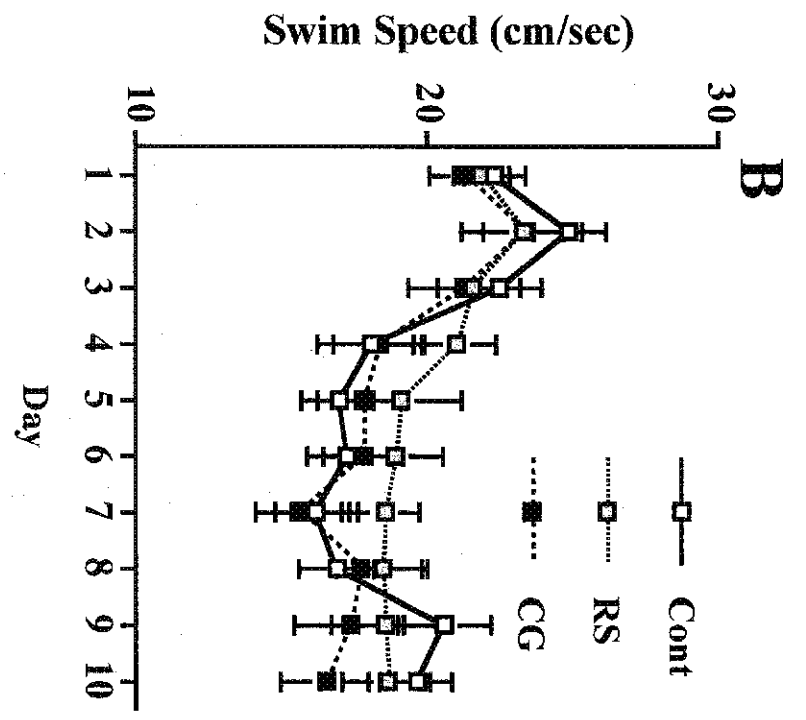
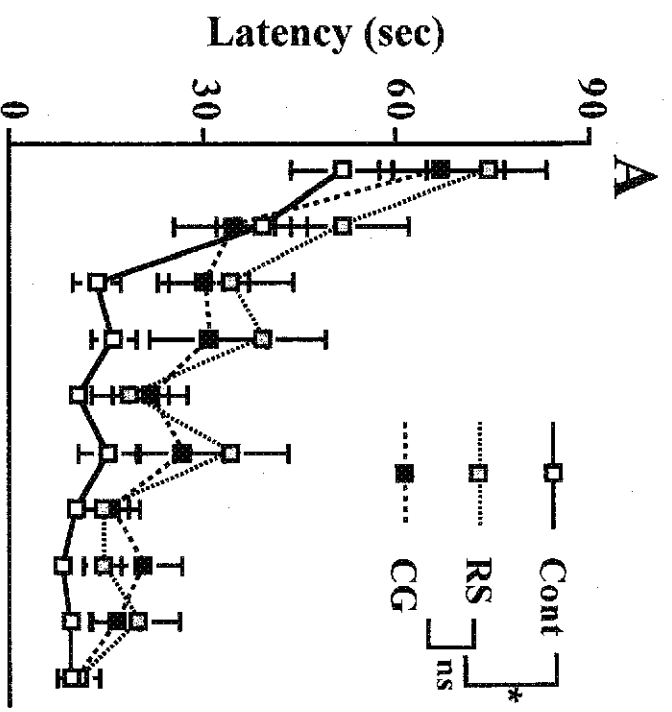
As the results from the measure of path length closely resembled those from the measure of latency, only the results from the measure of latency are reported here. This finding is supported by a lack of significant group differences in swim speed ( $F(2,19) = 0.303; p > 0.05$ ) (Fig 3.3B). Further, the lack of swim speed differences combined with a lack of significant differences in non-spatial performance errors ( $F(2,19) = 0.320; p > 0.05$ ) suggest that the group differences observed in the place task performance are the result of a spatial learning deficit and not the result of simple sensorimotor and/or non-spatial learning impairments.

There were no group differences in swim trajectory errors on the place task ( $F(2,19) = 1.940; p > 0.05$ ).

### **Probe Trial**

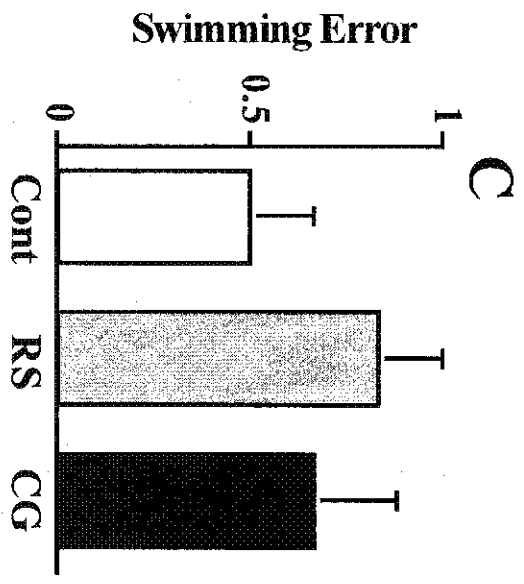
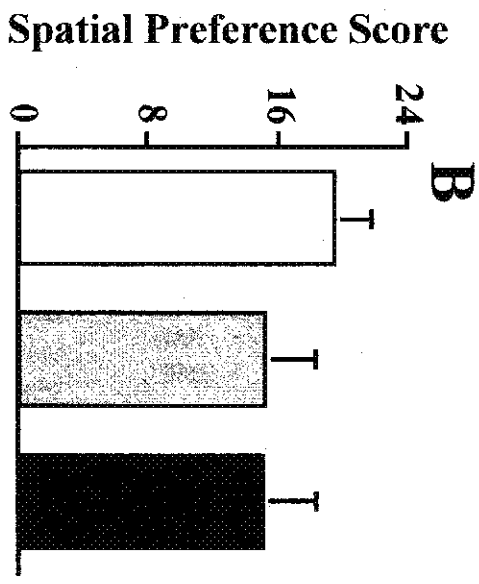
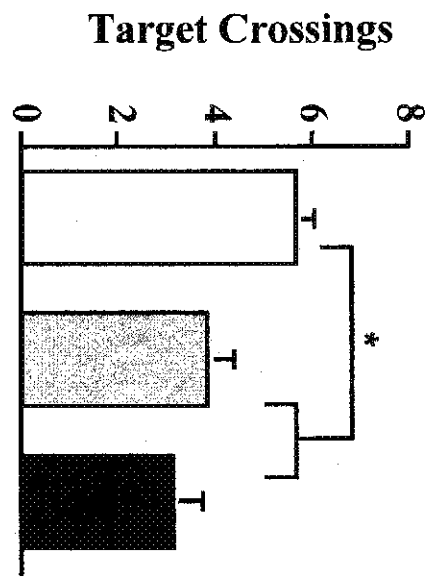
The results from the measure of target crossings were not consistent with those of the spatial preference score during the probe trial (Fig. 3.4). All groups displayed similar amounts of preference for the target quadrant as measured by the spatial preference score (where a score of 0 = no preference), (Fig. 3.4B). A one factor ANOVA on the measure

**Figure 3.3.** Place task acquisition performance (mean & SEM) across 10 days (two trials per day) on measures of Latency (*A*) and Swimming Speed (*B*) by control (*Cont*), retrosplenial (*RS*), and cingulum bundle (*CG*) rats. \* =  $p < .05$ .



*Figure 3.4.* Probe trial performance (mean & SEM) on measures of target crossings (*A*), spatial preference (*B*), and swimming accuracy errors (*C*) by control (*Cont*), retrosplenial (*RS*), and cingulum bundle (*CG*) rats. \* =  $p < .05$ .



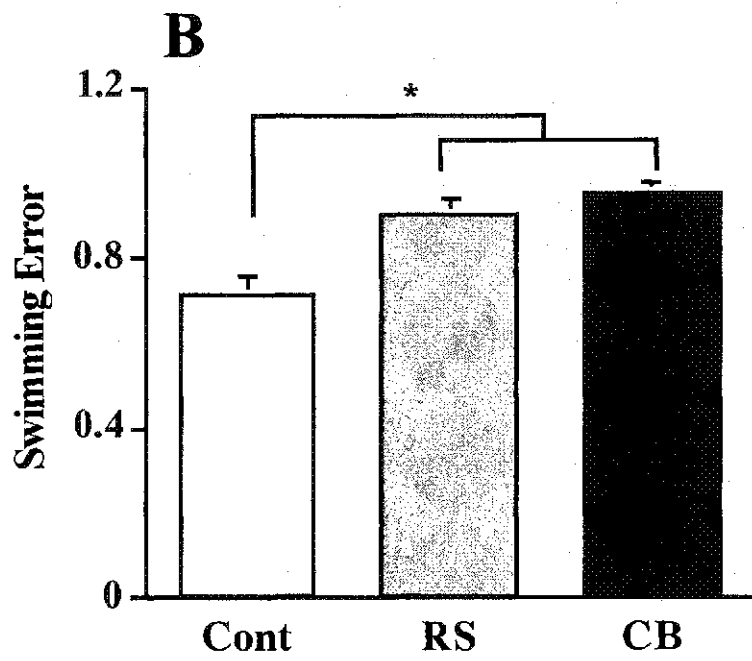
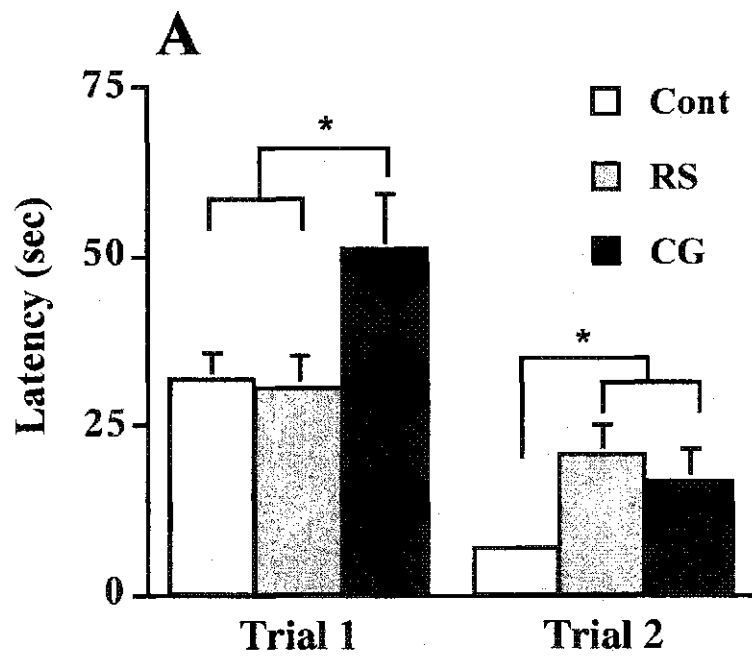


of target crossings however, yielded a significant group difference ( $F(2,19) = 7.366; p < 0.05$ ) (Fig. 3.4A) with a SNK post hoc test showing the differences to be: Control > RS = CG. These probe trial results suggest that although all of the groups were able to learn the general location of the platform, as indicated by the spatial preference scores, only the control group had learned the exact location, as indicated by the measure of target crossings.

### **Matching-to-Place Task**

Performance on the matching-to-place performance was consistent with the RS and CG deficits observed in the place task (Fig. 3.5). All groups demonstrated varying degrees of one trial learning as shown by a repeated measures (2 within, 1 between) ANOVA that found a significant group effect ( $F(2,19) = p < 0.05$ ) but just failed to find a significant group x trial interaction ( $F(2,19) = 3.039; p = 0.07$ ). A SNK post hoc test for the group effect showed the differences to be: Control < CG. However, the demands of the matching-to-place task differ from the place task in that subjects are required to learn a new place location in just one trial, as demonstrated by longer trial 1 latencies (an indication of memory for the previous days platform location) and very short trial 2 latencies (an indication of having learned the new location). Therefore, the first and second trials of the matching-to-place task were analysed separately in order to provide a more accurate assessment of performance (Fig. 3.5A). The results of a repeated measures (1 within, 1 between) ANOVA for trial 1 latencies found a significant group effect ( $F(2,19) = 3.645; p < 0.05$ ), with a SNK post hoc test showing the differences as being: Control < CG. The results of a repeated measures (1 within, 1 between) ANOVA for trial

*Figure 3.5.* Matching-to-place performance as illustrated by one-trial learning (latency mean & SEM) averaged over 5 sessions (A) and swim trajectory errors (mean & SEM) (B). \* =  $p < .05$ . Abbreviations: Control subjects (*Cont*); retrosplenial subjects (*RS*); cingulum bundle subjects (*CG*).



2 latencies also found a significant group effect ( $F(2,19) = 5.530; p < 0.05$ ). A SNK post hoc test showed the differences as being: Control < CG = RS.

The control group demonstrated superior accuracy in swimming straight for the platform on the matching-to-place task (Fig. 3.5B). A repeated measures (2 within, 1 between) ANOVA for swim trajectory errors during the matching-to-place task found a significant group effect ( $F(2,19) = ; p < 0.05$ ). A SNK post hoc test showed the group differences to be: Control < RS = CG. Combined, these results demonstrate an impaired matching-to-place performance by both the RS group and the CG group relative to the control group.

## DISCUSSION

A comparison of the effects of selective NMDA RS damage with selective CG transections using Long-Evans rats revealed the importance of both these structures for spatial behaviour in two different swimming pool tasks. Both the RS group and the CG group displayed impaired performances on both the place task and the matching-to-place task. These results replicate both results from previous studies finding CG spatial deficits (Neave *et al.*, 1994; Aggleton *et al.*, 1995; Warburton *et al.*, 1998) and from our study finding spatial deficits following selective RS aspiration lesions (Harker & Wishaw, 2002a). These results provide conclusive evidence of CG and RS contributions to spatial learning and suggest that the two structures make independent contributions to spatial behaviour.

In the present study, Long-Evans rats given either cytotoxic NMDA RS lesions or surgical CG transection were impaired on a number of spatial measures in a swimming

pool. In the swimming pool place task both RS and CG subjects took longer to learn the location of the hidden platform in a fixed location. On a probe trial given after initial training, although there were no significant differences between groups in their preference for the target quadrant, abnormal probe trial performance was detected by fewer target crossings over the exact location of the platform by both the RS and the CG groups. In the matching-to-place task both RS and CG subjects were impaired relative to control subjects in their ability to show one-trial learning at a level comparable to asymptotic place task performance by intact rats. It should be noted that neither lesion completely prevented spatial learning and memory, as indicated by the final trials of the place task, and spatial preference measure from the probe trial, but nonetheless, both RS and CG subjects were impaired.

It has been recently demonstrated that many impairments initially observed in swimming pool tasks are the result of non-spatial impairments (Saucier *et al.*, 1996). There are four lines of evidence to suggest that in the present study that the impairments are indeed spatial. First, there was no significant difference in swim speeds between the groups, ruling out the possibility of a simple sensorimotor influence. Second, both the lesion groups and the controls displayed very few behaviours indicative of sensorimotor or non-spatial impairments during place task performance, i.e., there were no differences in search patterns, failing to climb onto the platform, or jumping off the platform. Third, both RS and CG subjects made significantly fewer target crossings over the exact location of where the platform had originally been located than controls during the probe trial, even though they demonstrated knowledge of the correct quadrant. Fourth, both RS and CG subjects continued to display impaired performances on the matching-to-place

task, a task that is relatively more selective to spatial impairments, as subjects are well accustomed to the procedures of the swimming pool by the time this phase of testing begins (see Harker & Whishaw, 2002a).

The relative effects of RS damage on spatial behaviour have been in dispute. The debate has focussed on the type of lesion used as RS aspiration lesions (RS and CG inclusive) have typically produced large spatial deficits (Sutherland *et al.*, 1988; Kolb & Whishaw, 1991; Sutherland & Hoising, 1993; Whishaw *et al.*, 2001) while cytotoxic NMDA RS lesions (sparing CG) typically have not (Neave *et al.*, 1994; Aggleton *et al.*, 1995; Warburton *et al.*, 1998). Recent work however, has demonstrated spatial learning impairments following selective RS aspiration lesions also depends upon the rat strain used (Harker & Whishaw, 2002a). The finding of spatial deficits following selective NMDA RS lesions in the present study is consistent with the results from selective aspiration RS lesions (Harker & Whishaw, 2002a) suggesting that aspiration and cytotoxic lesions do not produce fundamentally different behavioural outcomes when restricted to the same regions. The size of the RS lesions in this study are comparable to those from previous studies using NMDA RS lesions in Dark Agouti rats that failed to produce RS deficits (Neave *et al.*, 1994; Aggleton *et al.*, 1995; Warburton *et al.*, 1998) as well as to the size of the selective aspiration RS lesions (Harker & Whishaw, 2002a) shown to result in impaired spatial performance. It should be noted that the spatial impairments observed on place task performance for the RS group was not as severe as those typically observed following hippocampal damage (Sutherland *et al.*, 1988) nor as those reported in previous RS aspiration lesion studies that were not selective for RS damage (Sutherland *et al.*, 1988; Kolb & Whishaw, 1991; Sutherland & Hoising, 1993;

Whishaw *et al.*, 2001). It is possible however, that this is simply a reflection of the smaller lesion size (Vann & Aggleton, 2002). Thus, the present findings of spatial learning impairments following NMDA RS lesions confirm an important role for RS in spatial navigation as RS damage, regardless of the how it was made, disrupts spatial learning.

Previous reports of CG involvement in spatial behaviour in a swimming pool are also confounded by a lack of lesion selectivity as the radiofrequency lesion method used in these studies appears to result in substantial amounts of accompanying damage to the surrounding cortex as well as to the underlying corpus callosum (for example see Warburton *et al.*, 1998). There are also reports that damage to the supracallosal pathway (cingulate cortex and cingulum bundle inclusive) fail to disrupt spatial learning and memory (Jeltsch *et al.*, 1994) although it should be noted that the lesions in this study were made in anterior portions of RS and in anterior cingulate cortex, and further that the CG does not appear to be consistently damaged. The detrimental effects of the CG lesions in the present study are not attributable to extraneous damage to other brain areas for three reasons: First, damage from surgical knife-cut transections of the CG was restricted to the immediate coordinates of the lesion, resulting in minimal damage to the overlying cortex and no apparent damage to the underlying corpus callosum. Second, the performance of the cortical knife-cut subjects (made at the same coordinates as the CG lesions) was indistinguishable from that of the control subjects. Third, the CG lesions were made at a point just anterior to RS, underneath anterior cingulate cortex – an area that even when extensively damaged has been shown to produce only mild, if any deficits on place navigation (Sutherland *et al.*, 1988; Whishaw *et al.*, 2001).



The results from the present study demonstrate and confirm important roles for both RS and CG in mediating spatial learning and memory. That both forms of damage produce similar levels of severity in impaired performance suggest three possibilities as to the nature of RS and CG contributions. The first possibility is that both structures are mediating the exact same mechanisms, thus, damage to one structure is equivalent to damaging the other, and combined RS + CG damage simply produces a redundant effect. Given that the CG is primarily a fibre pathway consisting mainly of axons and the RS is a cortical structure, along with the extensive connections between these structures, makes this possibility the least likely. It is possible that each structure makes a contribution of a completely different nature to spatial learning and memory, but that when damaged produce similar levels in the severity of spatial deficits. The different pattern of performance and impairments by the RS and CG groups on the matching-to-place task in this study may appear to support such a notion, but alone are insufficient.

It is also possible that the spatial deficits are due to damage to a diffuse pathway in the CG-RS region. Given that CG connects the hippocampal formation with many other cortical and subcortical structures, including RS, as well as the various cortical inputs to RS (Domesick, 1969; Vogt & Miller, 1983; Mufson & Pandya, 1984; Wyss & Van Groen, 1992) it is possible that there are many different types of information that may be used in spatial navigation that converge through this region on their way to the hippocampal formation. This is supported by electrophysiological evidence that both CG and RS form part of the pathway for atropine-resistant or Type I hippocampal theta activity, activity proposed to depend on the serotonergic system (Vanderwolf *et al.*, 1985; Kolb & Whishaw, 1991). Atropine-resistant or Type I theta is typically associated with

behaviours such as head movements, walking, rearing, etc, movements that are also used for spatial problem solving (Vanderwolf *et al.*, 1985; Kolb & Whishaw, 1991). This notion is also consistent with fact that larger lesions to this area tend to produce larger spatial impairments (see above discussion).

There is recent evidence that strain influences the results of studies investigating RS deficits (Harker & Whishaw, 2002a). It was thought important, therefore, to use Long-Evans rats in the present study to compare of the effects of selective RS and selective CG damage. Not only is this a rat strain that displays superior spatial performance (Harker & Whishaw, 2002b), it is also a strain that has been shown to display impairments following RS lesions (Harker & Whishaw, 2002a). Thus, the finding of both CG and RS impairments in Long-Evans rats in the present study is consistent with findings using other strains in which either CG lesions are performed (Neave *et al.*, 1994; Aggleton *et al.*, 1995; Warburton *et al.*, 1998) or large RS lesions are performed (Ennaceur, Neave, & Aggleton, 1997; Harker & Whishaw, 2002a; Vann & Aggleton, 2002).

In conclusion an understanding of the neural circuitry mediating spatial behaviour has been hindered over the last decade by conflicting reports over the relative contributions of RS and CG to spatial learning and memory. The results of the study in this chapter contribute to the resolution of this issue by demonstrating impaired spatial performance following both selective RS lesions and selective CG lesions. The results are most consistent with the notion of a diffuse pathway passing through this region important for providing the hippocampal formation with information relevant to spatial

processing. They are also consistent with electrophysiological evidence that these regions play a role in movement and in spatial behaviour.

## CHAPTER FOUR\*

### GENERAL DISCUSSION

#### **Introduction**

In the present thesis a re-examination of the role of retrosplenial cortex (RS) in place navigation in rats was conducted in light of evidence suggesting that damage to the adjacent cingulum bundle fibre tract (CG), and not to RS itself was responsible for the spatial learning impairments observed following lesions to this area. In the previous chapters I have demonstrated conclusively that RS is indeed important for place navigation by showing that selective RS damage, regardless of how it was made, is sufficient to produce spatial learning impairments. I further provided a novel explanation for the inconsistent reports over RS deficits in the literature in the form of a previously unrecognised strain influence that was able to mask the effect of an RS lesion resulting from the use of the Dark Agouti rat strain and insufficient spatial testing. I will now discuss the findings of my thesis in relation to the work of others who have studied the contributions of RS to spatial behaviour over the last twenty years.

Over the last two decades there has been considerable interest and debate over the contributions of RS to learning and memory. Initial behavioural evidence from both animals (Barker & Thomas, 1965; Sutherland *et al.*, 1988) and humans (Valenstein *et al.*, 1987) suggests a role for RS in learning and memory behaviours. RS is described as part of a transition zone between parietal and occipital neocortex ("new" cortex - six-layered laminar structure) and limbic archicortex ("old" cortex - heterogeneous laminar structure) (Zilles & Wree, 1995). RS is located along the midline of the brain, caudal to anterior cingulate cortex, medial to parietal and occipital cortical areas, and dorsal to the corpus

callosum, cingulum bundle, and parts of the hippocampal formation. RS makes reciprocal connections with its neighbouring anatomical areas, and is also connected to more distant structures such as the thalamus and medial temporal lobe cortex via pathways through the cingulum bundle (Domesick, 1969; Vogt & Miller, 1983; Pakhomova & Akopian, 1985; Wyss & Van Groen, 1992). The relationship between RS and the cingulum bundle support the suggestion that RS may also be a functional component of Papez circuit (Papez, 1937). The circuitry proposed by Papez consisted of: hippocampal formation, fornix, mammillary bodies of the hypothalamus, anterior dorsal thalamus, cingulum bundle, cingulate cortex, and back to the hippocampal formation. Although the Papez circuit was originally described as the anatomical substrate of emotion (Papez, 1937) all of the components of this circuit have also been shown to be involved in learning and memory processes and in particular, spatial learning and memory (Barker & Thomas, 1965; O'Keefe & Nadel, 1978; Morris *et al.*, 1982; Valenstein *et al.*, 1987; Sutherland *et al.*, 1988; Sutherland & Rodriguez, 1989; Aggleton *et al.*, 1990; Wishaw *et al.*, 1997; Sziklas & Petrides, 1998). Further, lesions to posterior neocortex, to which RS makes abundant reciprocal connections, have also been shown to disrupt spatial learning and memory (Pohl, 1973; Mesulam, 1981; Kolb, Sutherland, & Wishaw, 1983; Kolb *et al.*, 1994; Save & Moghaddam, 1996).

Electrophysiological evidence also suggests a functional relationship between RS and the hippocampal formation. Both RS lesions (Kolb & Wishaw, 1991) and temporary RS inactivation (Cooper & Mizumori, 2001) have been shown to affect hippocampal electrophysiology. Thus, the anatomical and electrophysiological evidence strongly support the proposed role for RS in bridging the neocortical and limbic

structures in the neural circuitry underlying spatial navigation (Pandya & Yeterian, 1984; Sutherland *et al.*, 1988).

Although the human literature has continued to provide evidence for a RS role in spatial behaviour (Katayama, Takahashi, Ogawara, & Hattori, 1999; Maguire, 2001), interpreting the RS evidence from the rodent literature has been complicated by consistent discrepancies in results. There are numerous differences between the studies that typically find RS deficits on spatial tasks (Sutherland *et al.*, 1988; Kolb & Whishaw, 1991; Sutherland & Hoising, 1993; Whishaw *et al.*, 2001), and those studies that do not (Neave *et al.*, 1994; Aggleton *et al.*, 1995; Warburton *et al.*, 1998). These differences include the type of RS lesion, the choice of spatial tasks used to assess spatial deficits and the choice of rat strain used in the studies. Differences in the type (and selectivity) of lesion between studies is the most widely accepted explanation for the differences, with the more selective cytotoxic lesions leading to the perplexing conclusion that RS is *not* involved in spatial learning and memory (Warburton *et al.*, 1998). Even more recently however, it has been demonstrated by the present author that the current controversy over the RS contribution to spatial behaviour is actually more related to the choice of spatial task and rat strain than it is to the type of lesion (Harker & Whishaw, 2002a; see Chapter Two). Thus, a review of previous RS studies with respect to strain and task influences becomes pertinent to an accurate understanding of the RS contribution to rodent navigation. These recent findings also validate emerging theories on the nature of RS contributions to spatial behaviour that have previously been undermined by the unexplained inconsistencies over RS deficits in the literature. Table 4.1 provides a

survey of the literature examining RS contributions to spatial behaviour over the last 20 years.

**Table 4.1.** A review of studies investigating retrosplenial cortex involvement in spatial behaviour over the past two decades. Noted is the type of lesion made, whether there was accompanying cingulum bundle (CG) damage, the tasks used, and the results obtained.

Study	Rat Strain	Lesion Method	CG damage	Spatial Tasks	Results
<i>(Sutherland et al., 1988)</i>	Long-Evans (male)	Suction Ablation	Yes	Swimming Pool Place Task	Impaired
				Swimming Pool Matching-to-Place Task	Impaired
<i>(Kolb &amp; Whishaw, 1991)</i>	Long-Evans (male)	Suction Ablation	Yes	Swimming Pool Place Task	Impaired
				Swimming Pool Matching-to-Place Task	Impaired
<i>(Sutherland &amp; Hoising, 1993)</i>	Long-Evans	Unilateral Suction Ablation	Yes	Swimming Pool Place Task	Unimpaired
				Swimming Pool Matching-to-Place Task	Unimpaired
				Swimming Pool Probe Trial	Unimpaired
		Bilateral Suction Ablation	Yes	Swimming Pool Place Task	Impaired
				Swimming Pool Matching-to-Place Task	Impaired
		Swimming Pool Probe Trial	Impaired		



Study	Rat Strain	Lesion Method	CG damage	Spatial Tasks	Results
<i>(Sutherland &amp; Hoising, 1993)</i> <i>(continued)</i>		Unilateral Suction Ablation + Unilateral Quisqualic Acid	Uni-lateral damage	Swimming Pool Place Task	Impaired
				Swimming Pool Matching-to-Place Task	Impaired
				Swimming Pool Probe Trial	Impaired
<i>(Neave et al., 1994)</i>	Dark Agouti	Neurotoxic - NMDA	No	Delayed Non-Matching-to-Position in an Operant Chamber	Unimpaired
				Forced-Alternation in a T-Maze	Unimpaired
<i>(Riekkinen, Kuitunen, &amp; Riekkinen, 1995)</i>	Wistar	Cholinergic blockade by scopolamine infusions	No	Swimming Pool Place Task	Impaired
<i>(Aggleton et al., 1995)</i>	Dark Agouti	Neurotoxic - NMDA		Delayed Non-Matching-to-Position Task (Operant Chamber)	Unimpaired
				Forced-Alternation in a T-Maze	Unimpaired

Study	Rat Strain	Lesion Method	CG damage	Spatial Tasks	Results	
<i>(Li &amp; Low, 1997)</i>	Sprague-Dawley	Aspiration	Yes	Swimming Pool Place Task	Impaired	
				Swimming Pool Probe Trial	Impaired	
				T-Maze Alternation	Impaired	
		Fetal cholinergic cell transplant into RS			Swimming Pool Place Task	Amelioration
					Swimming Pool Probe Trial	Amelioration
					T-Maze Alternation	Amelioration
<i>(Ennaceur et al., 1997)</i>	Dark Agouti	Neurotoxic - NMDA	No	Object Location Memory Task	Impaired	
<i>(Warburton et al., 1998)</i>	Dark Agouti	Neurotoxic - NMDA	No	Swimming Pool Place Task	Unimpaired	
				Swimming Pool Probe Trial	Unimpaired	
				Forced-Alternation in a T-Maze	Unimpaired	
<i>(Cooper &amp; Mizumori, 1999)</i>	Long-Evans	Temporary Inactivation by Tetracaine	Yes	8 Arm Radial Arm Maze - Light Condition	Unimpaired*	
				8 Arm Radial Arm Maze - Dark Condition	Impaired	

Study	Rat Strain	Lesion Method	CG damage	Spatial Tasks	Results
<i>(Cooper &amp; Mizumori, 2001)</i>	Long-Evans	Temporary Inactivation by Tetracaine	Yes	8 Arm Radial Arm Maze - Light Condition	Impaired*
				8 Arm Radial Arm Maze - Dark Condition	Impaired
<i>(Whishaw et al., 2001)</i>	Long-Evans	Suction Ablation	Yes	Whishaw Foraging Task - Ideothetic Condition (Dark)	Impaired
				Whishaw Foraging Task - Allothetic Matching-to-Place)	Impaired
				Swimming Pool Place Task	Impaired
				Swimming Pool Probe Trial	Impaired
<i>(Alexinsky, 2001)</i>	Sprague-Dawley	Cortical Excision		8 Arm Radial Arm Maze	Unimpaired
<i>(Cooper et al., 2001)</i>	Long-Evans	Temporary Inactivation by Tetracaine	Yes	Whishaw Foraging Task - Light & Dark condition (Exp. 1)	Impaired
<i>(Harker &amp; Whishaw, 2002a)</i>	Long-Evans	Suction Ablation - Specific to retrosplenial cortex	No	Swimming Pool Place Task	Impaired
				Swimming Pool Probe Trial	Impaired

Study	Rat Strain	Lesion Method	CG damage	Spatial Tasks	Results	
<i>(Harker &amp; Whishaw, 2002a) (Continued)</i>		Suction Ablation - RS + CG	Yes	Swimming Pool Matching-to-Place Task	Impaired	
				Swimming Pool Place Task	Impaired	
				Swimming Pool Probe Trial		
	Dark Agouti	Suction Ablation	No	Swimming Pool Matching-to-Place Task	Impaired	
				Swimming Pool Place Task	Unimpaired**	
				Swimming Pool Probe Trial	Impaired	
<i>(Harker &amp; Whishaw, in Press) (Chapter 3)</i>	Long-Evans	Neurotoxic (NMDA)	No	Swimming Pool Matching-to-Place Task	Impaired	
				Swimming Pool Place Task	Impaired	
				Swimming Pool Probe Trial	Impaired (Tcings)	
					Swimming Pool Matching-to-Place Task	Impaired
					Swimming Pool Place Task	
					Swimming Pool Probe Trial	
<i>(Vann &amp; Aggleton, 2002)</i>	Dark Agouti	Neurotoxic (NMDA) - more extensive lesions	No	8 Arm Radial Arm Maze	Impaired	
				Swimming Pool Place Task	Impaired	

Study	Rat Strain	Lesion Method	CG damage	Spatial Tasks	Results
<i>(Vann &amp; Aggleton, 2002) (Continued)</i>				Swimming Pool Probe Trial	Impaired (Tcings)
				Object Location Memory	Impaired

Abbreviations: retrosplenial cortex (*RS*); cingulum bundle (*CG*); target crossings (*Tcings*); N-methyl-D-aspartate (*NMDA*).

\* Subjects in the 2001 study, a spatial impairment is demonstrated when subjects are trained under retrosplenial cortex inactivation

\*\* The spatial impairment normally produced by retrosplenial damage was shown in this study to be masked by an inherent nonspatial/spatial learning impairment in occurring in the Dark Agouti Strain.

### **Evidence in Favour**

The first investigation of RS damage on spatial behaviour assessed the effects of RS damage on Morris Water Task (MWT) performance (Sutherland *et al.*, 1988). The MWT was designed as a measure of locale or place navigation ability (Sutherland, Whishaw, & Kolb, 1980; Morris, 1981). At its simplest, locale navigation is a form of spatial behaviour in which a subject is able to locate one object or place in relation to two or more surrounding objects. This ability is illustrated by the behaviour of rats in the MWT. The task requires a rat to swim around in a swimming pool that allows it to escape only if it finds a platform hidden just below the surface of the water at a fixed location in the swimming pool. Within a few trials rats rapidly locate the platform from any starting position in the pool. Over the years a number of variations of the MWT have been described. The standard version of the MWT is often referred to as the place task version as the platform remains in the same location across training days. A probe trial may also be used to assess how well the subject has learned the platform location by removing the platform from the pool and observing the behaviour of the subject. Although the measure of quadrant preference or how much time the subject spends in the correct quadrant is the most common measure of having learned the platform location, there is strong evidence to suggest that the number of passes the subject makes over the location of the missing platform is a better indicator of learning and memory (Harker & Whishaw, 2002a). Another commonly used variation of the MWT is described as a matching-to-place task. During matching-to-place testing the platform is moved to a new location every day and the ability of the subject to learn the new location (matching to the new place learned during the initial trial on every day).

Sutherland *et al.* (1988) found that rats with bilateral suction ablation RS lesions were impaired on both a place task and a matching-to-place in the MWT. This was the first report of evidence suggesting a retrosplenial contribution to spatial navigation. The subjects were not impaired relative to controls in finding a visible platform, supporting the notion that the observed deficits were indeed the result of an impaired ability to move accurately to locations in space using relationships among distal cues. Kolb & Whishaw (1991) also found that bilateral suction ablation RS lesions impaired performance on both place and matching-to-place versions of the MWT. In addition, the RS lesions in this study eliminated atropine-resistant (Type I) hippocampal theta, electrical activity associated with voluntary behaviours and movement (Vanderwolf, 1969). The finding that RS damage disrupts hippocampal Type I theta as well as impairs hippocampal-dependent spatial behaviours suggests an important role for RS in locale navigation.

Further evidence of RS deficits during locale navigation has been reported on place (Sutherland & Hoelsing, 1993; Whishaw *et al.*, 2001) and matching-to-place testing (Sutherland & Hoelsing, 1993) in the MWT and a dry-land matching-to-place task (Whishaw *et al.*, 2001) following bilateral RS suction ablation as well as RS deficits in object location memory following cytotoxic RS lesions (Ennaceur *et al.*, 1997).

There is evidence to suggest that RS lesions also impair another form of hippocampal-dependent spatial navigation referred to as path integration (Whishaw & Jarrard, 1996; Whishaw & Maaswinkel, 1998; Maaswinkel *et al.*, 1999). Path integration is a form of spatial navigation in which the subject is guided by internal or ideothetic cues generated by their own movements (Darwin, 1873; Barlow, 1964; Mittelstaedt & Mittelstaedt, 1980; Seguinot *et al.*, 1993). Path integration requires a subject to integrate

self-movement generated cues during an outbound trip in order to determine its present position as well as the most direct route home. These ideothetic cues may include information from muscle, joint, and tendon receptors, vestibular input, flow of optic, auditory, and olfactory stimuli, as well as efference copy information derived from structures that mediate movements (Whishaw, 2000). Path integration is best demonstrated by the behaviour of rats on the Whishaw Foraging Task in the dark (Whishaw & Maaswinkel, 1998; Whishaw *et al.*, 2001). The testing apparatus consists of a circular table with evenly spaced holes along the perimeter under which the home cage of a rat may be placed. A subject will leave its home cage and search the table in a random fashion until it locates a food pellet, at which point the rat then quickly takes the shortest route back to the home location to consume the food reward. This direct route home can be made without the aid of visual, auditory, or olfactory cues.

Evidence of RS spatial deficits has also been demonstrated following temporary inactivation of RS and 8-radial arm maze (RAM) testing in both light (Cooper & Mizumori, 2001) and dark (Cooper & Mizumori, 1999; Cooper *et al.*, 2001; Cooper & Mizumori, 2001) conditions. The RAM is another common test that was designed to assess spatial behaviour (Walker & Olton, 1979; Becker, Walker, & Olton, 1980). The apparatus typically consists of a central octagonal shaped platform with eight protruding arms with access to any of the arms controlled by the experimenter. In the light, the behavioural demands of the RAM are similar to those of the place task in the MWT, in that subjects must learn to find food items located at the ends of certain arms relative to surrounding cues in the room (as opposed to locating a submerged platform). Successful RAM performance in the dark however, requires the rat to rely more heavily on a path



integration strategy, as in the Wishaw Foraging Task. Thus, results from RS inactivation studies show RS contributions to both place navigation and path integration.

### **Evidence Against**

Although there is substantial behavioural evidence in rodents finding RS deficits on a variety of spatial tasks, a number of studies using relatively more selective cytotoxic N-Methyl-d-Aspartic Acid (NMDA) lesions have failed to observe RS deficits, (Neave *et al.*, 1994; Aggleton *et al.*, 1995; Warburton *et al.*, 1998). Neave *et al.* (1994) and Aggleton *et al.* (1995) were the first to report a non-effect of RS lesions on certain tests of spatial memory. In these two studies rats were tested in both an automated operant chamber on a delayed non-matching-to-position (DNMP) task, as well as in a T-Maze on an alternation task. The automated operant chamber used for the DNMP testing contained two levers, with a light over each lever to act as an extra cue, as well as a tray for providing food pellets. Typically, a subject is rewarded (either by food or electrostimulation) for pressing a lever. In the DNMP paradigm a subject is presented with only one lever (the sample) to press, the subject must then perform set of operantly conditioned behaviours following which the subject is then presented with both levers. The subject is only rewarded with a food pellet when it presses the lever that had not been the sample lever, hence the “non-matching-to-position” requirement of the task.

The T-Maze is simply a three-arm maze in the shape of the letter “T”. One of the arms serves as a starting runway with the other two arms serving as the choice arms. Similar to the RAM, subjects are trained to retrieve food rewards from the ends of the choice arms. In forced alternation testing in the T-Maze, a subject is given two trials the

first of which is a forced-choice sample, meaning that access is permitted to only one of the choice arms. On the second trial access is permitted to both choice arms however, the subject must now learn to choose the alternate or opposite arm in order to retrieve the food reward. The results of the Neave *et al.* (1994) and the Aggleton *et al.* (1995) studies showed no RS deficits, but did find cingulum bundle deficits on the DNMP and T-Maze alternation tasks.

The lack of RS deficits on DNMP in an operant chamber and the T-Maze are interesting however, there is some debate over the validity of these tasks as measures of spatial ability and their comparison with tasks such as the MWT and Whishaw Foraging Task (to be discussed later on). Warburton *et al.* (1998) addressed this issue by testing rats with selective cytotoxic RS lesions on a place task in the MWT and on forced alternation in the T-Maze. The results of this study showed cingulum bundle, but not RS deficits in the T-Maze, as well as on place task performance in the MWT. A lack of RS deficits using surgical ablation on place task performance has also been demonstrated in the RAM (Alexinsky, 2001).

It is interesting to note that the studies failing to find RS spatial deficits did find spatial deficits following lesions to the cingulum bundle, as this structure is often inadvertently damaged during RS suction ablation lesions. The evidence of cingulum bundle deficits however, should not be surprising given it is a major input and output pathway of RS. What is surprising is that selective damage to RS does not produce spatial deficits when damage to one of its primary efferent and afferent pathways does. Nonetheless, given the evidence of cingulum bundle damage in almost every study using suction ablation RS lesions, it would appear that the behavioural deficits observed in

these studies are quite possibly the result of damage to the cingulum bundle, and not to RS itself. This is the argument put forward by the authors of studies that have typically failed to observe RS deficits on certain tasks of spatial behaviour (Neave *et al.*, 1994; Aggleton *et al.*, 1995; Neave, Nagle, Sahgal, & Aggleton, 1996; Neave *et al.*, 1997; Warburton *et al.*, 1998) and as outlined above is supported by substantial amounts of behavioural evidence. These findings appear to strongly support the conclusion that retrosplenial cortex is not necessary for spatial navigation tasks. Given the anatomical and electrophysiological evidence all indicating otherwise, this finding poses an interesting problem to our understanding of the neural circuitry underlying spatial behaviour.

#### **A Retrosplenial Reconciliation**

The most parsimonious explanation for the contradictory results in the rodent RS literature has been recently demonstrated by Harker & Whishaw (2002a). This study re-examined the issue of cortical vs. fibre tract damage as well as the possible influence of strain differences between studies with conflicting results. The results of this study revealed a number of important insights into the RS question as well as the study of spatial behaviour in general.

First, it was shown that rats with RS aspiration lesions in which the cingulum bundle was spared, still showed deficits on place task and matching-to-place task performance in the MWT. Thus, reconciling the behavioural results in rats with the previously obtained anatomical, electrophysiological and behavioural results from both humans and animals.

Second, it was found that rats with combined removal of RS and cingulum bundle were impaired relative to controls, but no different from the subjects with selective RS damage. These results reconfirmed the importance of RS contributions to tasks of spatial navigation. Further, the finding that cingulum bundle damage in conjunction with RS damage impaired performance no worse than selective RS damage suggests a close functional relationship between these two structures such that damage to one structure simply disconnects the other from the neural circuitry underlying spatial behaviour. Although the authors did not directly test the effects of selective cingulum bundle lesions at this time, unpublished results (Chapter Three) from subsequent studies in this lab lend support to this idea by showing that selective knife-cut cingulum bundle lesions produce impairments similar to selective cytotoxic lesions on place task and matching-to-place task performance in the MWT. Thus, cingulum bundle damage that may accompany an RS aspiration lesion (and vice versa) may be redundant in that it simply disrupts a neural circuit that is already dysfunctional.

Third, it was shown that the previous inconsistencies concerning RS spatial deficits were in fact the result of influences from rat strain and spatial task differences between studies typically finding RS deficits and those typically failing to find RS deficits. The investigation of a possible strain influence was triggered by the observation that Long-Evans rats were typically used in studies that found RS spatial deficits, while Dark Agouti rats were typically used in studies failing to find RS deficits (Table 4.1). To investigate the possibility of a strain influence I compared the performance of RS lesioned Dark Agouti rats with control Dark Agouti rats and control Long-Evans rats on a place task and a matching-to-place task in the MWT (Harker & Whishaw, 2002a). The

results from this comparison showed no significant differences between the place task performance by Dark Agouti control subjects and Dark Agouti RS subjects, similar to previous studies reporting no RS spatial deficits in Dark Agouti rats in the MWT (Warburton *et al.*, 1998). The results also showed however, that both the Dark Agouti control and the Dark Agouti RS groups were impaired on place task performance relative to the Long-Evans group. Of further interest were the results of the matching-to-place task in the swimming pool (a task not used in the previous studies that have failed to find RS spatial deficits), where the performance of the Dark Agouti RS subjects was clearly impaired relative to the Dark Agouti control and the Long-Evans control rats. Further, an analysis of non-spatial learning impairments on the place task showed significantly more non-spatial errors by both Dark Agouti groups (which did not differ from each other) compared to the Long-Evans rats.

What is most interesting is that these results replicate the findings of studies both finding and failing to find RS deficits suggesting that the RS controversy in rodents lies not in the inappropriateness of the RS aspiration lesion, but rather in the inappropriate use of the Dark Agouti strain for the study of spatial navigation (as indicated by the inherent non-spatial learning impairments), combined with the failure to use appropriate testing measures to detect this. Thus, the results from the Harker & Whishaw study (2002a) appear to provide the simplest explanation for the previous inconsistencies in the RS literature as being the result of unrecognised strain and task influences.

### **The Influence of Strain**

The observation of a strain effect overshadowing the effect of a brain lesion may at first seem surprising. Although strain differences are generally recognized as a potential variable in an experiment, they are often downplayed given that almost every commercial laboratory rat strain available is derived from the same species – *Rattus norvegicus*. Recent evidence however, suggests that the development of different strains during the domestication of *Rattus norvegicus* for research purposes has resulted in significant differences in the behavioural and physiological properties of many of the common or “general-purpose” rat strains (as well as the not so common Dark Agouti strain), in spite of their common ancestry (Harker & Whishaw, 2002a; Harker & Whishaw, 2002b; Mechan *et al.*, 2002; Prusky, Harker, Whishaw, & Douglas, 2002).

The strain comparisons made by Harker & Whishaw (Harker & Whishaw, 2002b) are of particular relevance to the current discussion as the different rat strains in this study were compared on the performance of spatial tasks in the MWT. The results of this study showed that many laboratory rat strains (including the Dark Agouti strain) are impaired relative to the Long-Evans strain, with impairments being more pronounced on the place task than on the matching-to-place task. Further, it was also demonstrated that the performance of the Long-Evans strain matched most closely to the performance of a wild strain of *Rattus norvegicus*, thus ruling out the possibility that the Long-Evans has been bred to be a “super” strain. Although not discounting the usefulness of other rat strains, these results do suggest that the Long-Evans strain may be a better choice than the Dark Agouti strain when examining the role of a various brain structures involved in spatial navigation in the species *Rattus norvegicus*. Indeed, strain influences may be

contributing to many current debates in many fields of research using rat models, and not just the debate over RS contributions to spatial navigation.

### **The Influence of Task**

That Dark Agouti rats do show RS deficits under certain conditions (see Table 4.1) (Ennaceur *et al.*, 1997; Harker & Whishaw, 2002a; Vann & Aggleton, 2002), illustrates that the debate over RS contributions to spatial navigation in rats is further complicated by an influence of spatial task demands. A wide variety of tasks have been developed for the assessment of a variety of behaviours in rodents in which performance should be measured both quantitatively and qualitatively (Whishaw *et al.*, 1983; Whishaw, Haun, & Kolb, 1999). In order to understand how a task influence can interfere with the proper interpretation of behavioural outcomes it must be understood that just as all behavioural tasks are not designed to measure the same behaviour, neither do most tasks selectively measure the behaviour for which they were designed. Failure to heed these two principles can result in the failure to find deficits when they actually do exist, or in the finding of deficits that in fact do not exist. It is the former error that appears to have occurred during the study of RS contributions to spatial navigation in the rat.

As shown in Table 4.1, a number of different tasks have been used to evaluate RS lesions including the place task and the matching-to-place task in the MWT, forced alternation in a T-Maze, a DNMP task in an operant chamber, and RAM performance, and the Whishaw foraging task – all of which have been described in some detail earlier in this review. Although all of these tasks have been labelled (and perhaps

inappropriately so) as “spatial” tasks, not all of these tasks were designed with spatial behaviour in mind, nor are all of them selectively a spatial task. Unlike tasks, such as the place navigation tasks in the MWT, the Whishaw Foraging Task, and the RAM, where the tasks were designed as measures of spatial behaviour, the T-Maze and operant chamber were initially designed as rule learning tasks. Although it is true that there may be some visual-spatial components in the T-Maze and DNMP tasks, there is some question as to the classification of these tasks as “spatial” as it is clear that they do not measure spatial navigation at the same level as the MWT or the Whishaw Foraging Task. This issue is important to understanding the debate over RS contributions to spatial behaviour as performance in both the T-maze and operant DNMP tasks have been used repeatedly as evidence that RS lesions do not affect spatial behaviour (Neave *et al.*, 1994; Aggleton *et al.*, 1995; Warburton *et al.*, 1998). The reason for the ambiguity surrounding the classification of the T-Maze alternation and operant DNMP tasks as spatial tasks is a result of inappropriately defining a spatial task as one that is “hippocampal-dependent”.

This defining criterion of a spatial task has come about from O’Keefe and Nadel’s proposal that the hippocampus is the central brain structure for mediating spatial behaviour (O’Keefe & Nadel, 1978), a theory that has subsequently been supported by a mass of experimental evidence in both humans and animals. Given the substantial evidence for a hippocampal role in spatial behaviour, the evidence for non-spatial functions of the hippocampus often receive less attention, but nonetheless still exists (see for example Clark, Broadbent, Zola, & Squire, 2002). Given the evidence of hippocampal involvement in non-spatial behaviours, it becomes clear that defining a task



as spatial on the basis that it is sensitive to hippocampal damage would be inappropriate. A “hippocampal-dependent” definition of spatial tasks increases the likelihood of errors stemming from the first principle of behavioural assessment – not all tasks measure the same behaviour. In other words, just because a task is sensitive to hippocampal damage, it is not necessarily a spatial task as the hippocampus may be sensitive to non-spatial as well as spatial tasks. Thus the T-Maze and operant DNMP tasks may be more appropriate as tools for confirming hippocampal damage and/or general rule learning rather than for measuring spatial impairments following lesions to extra-hippocampal brain structures such as RS. Further, the conclusion that RS is not important for spatial behaviour based on a lack of behavioural impairments in the T-Maze and operant DNMP tasks (Neave *et al.*, 1994; Aggleton *et al.*, 1995; Warburton *et al.*, 1998) may be somewhat misleading.

The RAM is a task in which the effects of RS damage vary depending on the task parameters (see Table 4.1). RS damage consistently impairs RAM performance in the dark; performance in light conditions however, has been more variable. Although the RAM, like the MWT, is one of the most popular tasks for measuring spatial behaviour, it has important differences in the types of cues available, task requirements, and task motivation when compared to the MWT (for review see (Hodges, 1996)). The findings from Hodges review, suggest fundamental differences between the RAM and MWT in the way they measure spatial deficits. Hodges describes the MWT as superior for analysing the selective contributions of a variable to spatial processing but less effective in assessing long-term memory impairments, whereas the RAM is described as being best suited for measuring stable memory impairments, but lacks the ability to accurately

detect the nature of the spatial deficit (Hodges, 1996). Given that RS lesions only impair, rather than completely prevent, spatial learning in the MWT (Harker & Whishaw, 2002a) it is possible that the amounts of training given pre and post operatively in the RAM may influence the ability of this task to detect RS impairments. Evidence to support this comes from the finding of RS deficits on RAM performance under light conditions in rats with RS inactivation during training on the RAM tasks, but not in rats with post-training RS inactivation (Cooper & Mizumori, 2001). Thus, caution must be used even when comparing the results from two tasks designed to measure the same behaviour, such as the RAM and the MWT.

That task influences contributed to the lack of findings of RS deficits in Dark Agouti rats even in the MWT (Warburton *et al.*, 1998; Harker & Whishaw, 2002a) has been demonstrated by Harker & Whishaw (2002a). The task influence underlying the failure to observe RS deficits in Dark Agouti rats in the MWT is related to the second principle of behavioural assessment – not all tasks are selective to the behaviour for which they were designed. Unlike the T-Maze and operant DNMP tasks however, the MWT was developed specifically as a task of spatial behaviour. It is important to recognize however, that neither the place task nor the matching-to-place task in the MWT is selective to place learning. Place learning in a swimming pool requires considerable learning of the non-spatial procedural components of the task prior to an accurate demonstration of place navigation (Whishaw, 1985a; Cain & Saucier, 1996).

Thus, it is possible that during initial testing in the MWT non-spatial learning impairments may be sufficient to mask the effects of a lesion-induced spatial impairment, a possibility that is confirmed by the findings of Harker & Whishaw (2002a). In other

words, the natural MWT performance of a subject with non-spatial learning impairments may be sufficiently poor so as to overshadow any lesion-induced effects. Upon learning the procedural components of the MWT however, a normal performance then becomes dissociable from that of a lesion-induced impaired performance. As described earlier, the Dark Agouti strain has been shown to display several non-spatial learning abnormalities (Harker & Whishaw, 2002a; Mehan *et al.*, 2002). Thus, the lack of RS deficits in the study by Warburton *et al.* (1998) is most likely the result of using a rat strain with considerable non-spatial learning impairments (the Dark Agouti strain) combined with a failure to use sufficient behavioural measures to recognize and dissociate the RS spatial deficit from the non-spatial learning impairment.

#### **An Alternative Explanation**

It should be noted that another explanation for the differences in results following RS lesions has also been recently proposed. Vann & Aggleton (2002) have recently confirmed the Harker & Whishaw (2002a) findings of RS deficits in Dark Agouti rats in the MWT, but only after extensive lesions to the retrosplenial area. Vann & Aggleton propose that the previous inconsistencies in the RS literature are the result of insufficient RS damage with excessive sparing of the caudal regions in previous studies using cytotoxic NMDA lesions (Vann & Aggleton, 2002). This argument however, is not the most parsimonious explanation for a number of reasons. First, Dark Agouti rats with sparing to the caudal portions of RS still showed object location memory impairments (Ennaceur *et al.*, 1997). Second, relatively small RS lesions using either an aspiration or a cytotoxic NMDA lesion technique have been shown to produce impaired performance

in the MWT, in spite of sparing the most caudal regions of RS (Harker & Whishaw, 2002a; Chapter Three). The finding of impaired place task performance by extensive RS lesions in Dark Agouti rats by Vann *et al.* (2002) is consistent with the original behavioural results obtained by Sutherland *et al.* (1988), but alone cannot adequately explain the inconsistencies in the existing RS data. There are three lines of evidence to support this. First, similar spatial deficits can be obtained in Long-Evans rats with smaller RS lesions (Harker & Whishaw, 2002a). Second, the inherently abnormal performance of Dark Agouti rats on both spatial and non-spatial behavioural tasks (Harker & Whishaw, 2002a; Mehan *et al.*, 2002). The third line of evidence is the finding of spatial deficits *only* after extensive RS lesions. These findings all support the idea that the Dark Agouti strain may be inappropriate for investigating normal brain-behaviour relationships.

### **The Nature of the Deficit**

This review of the RS contributions to spatial navigation in rats suggests that RS is indeed importantly involved in spatial navigation. Given the anatomical location and functional connections of RS as described previously, the spatial deficits observed following RS damage are most likely the result of a disconnection of the hippocampal formation and other limbic structures mediating spatial behaviour from cortical sensory and motor inputs. In support of this is the observation that the nature of RS lesions is such that they appear to disrupt both allothetic (place navigation) and ideothetic (path integration) forms of spatial navigation. This finding combined with the evidence of hippocampal involvement in both place navigation (O'Keefe & Nadel, 1978) and path

integration (Whishaw *et al.*, 1997) suggest that the same neural circuitry may be mediating both forms of navigation however, defining the precise contributions of the hippocampus to spatial or non-spatial behaviours is beyond the scope of this review. The findings of this review however, do support the general theory of RS acting as an interface or site of integration between allothetic or external information and internally generated movement related information used for the production of accurate navigation behaviours (Sutherland & Hoising, 1993; Chen *et al.*, 1994a; Cooper & Mizumori, 2001). In other words, it is possible that RS deficits are the result of an individual's inability use place navigation and path integration mechanisms in concert with each other, rather than disruption to the particular mechanisms themselves. This may explain why RS lesions impair but not prevent spatial learning as the mechanisms underlying these two forms of navigation are still in place, but alone are much less efficient in producing accurate navigation than when combined. A deficit of this nature would also be particularly vulnerable to the effects of strain and task that have herein been described, as it may be a deficit involving two forms of spatial navigation as opposed to one.

## **Conclusion**

A review of the literature concerning the contributions of RS to spatial navigation demonstrates the complexity of behavioural analysis in laboratory rats. The first ten years of studies produced conflicting results and reports over the importance of RS for spatial navigation. The source of the discrepant results has recently been shown to be the result of strain and task differences between studies that consistently found RS deficits and studies that did not. The reconciliation of the behavioural evidence in rats, with the

anatomical, electrophysiological, and behavioural evidence in both rodents and humans, strengthens our current understanding of the neural circuitry underlying spatial behaviour and removes what has been an obstacle to the continued investigation of these circuits and mechanisms.

In summary, the work described in the present thesis brings resolution to two seemingly irreconcilable sets of behavioural results concerning the involvement of RS in place navigation. This resolution was accomplished by assessing the differences between the strains and lesions used in studies that have typically reported RS deficits, with those used in studies that typically failed to find such deficits. The results of this thesis show that RS damage does indeed impair place navigation performance and that this impairment is in fact the result of an impaired spatial learning ability. The results of this thesis also demonstrate the importance of CG contributions to spatial learning and memory that appear to be independent of the RS contributions. Finally, this thesis provides the first demonstration of the significance of rat strain and spatial task for the assessment of brain-behaviour relationships by illustrating how a strain influence was able to mask the effect of brain damage, and hindering the progress in our understanding of the brain circuitry mediating spatial navigation for almost a decade.

\* This chapter is modified from a paper submitted for publication to *Neuroscience & Biobehavioural Reviews*.

## REFERENCES

- Aggleton JP, Hunt PR, Shaw C. (1990). The effects of mammillary body and combined amygdalar-fornix lesions on tests of delayed non-matching-to-sample in the rat. *Behav Brain Res*, 40(2), 145-157.
- Aggleton JP, Neave N, Nagle S, Sahgal A. (1995). A comparison of the effects of medial prefrontal, cingulate cortex, and cingulum bundle lesions on tests of spatial memory: evidence of a double dissociation between frontal and cingulum bundle contributions. *J Neurosci*, 15(11), 7270-7281.
- Aggleton JP, Vann SD, Oswald CJ, Good M. (2000). Identifying cortical inputs to the rat hippocampus that subserve allocentric spatial processes: a simple problem with a complex answer. *Hippocampus*, 10(4), 466-474.
- Alexinsky T. (2001). Differential effect of thalamic and cortical lesions on memory systems in the rat. *Behav Brain Res*, 122(2), 175-191.
- Barker DJ, Thomas GJ. (1965). Ablation of cingulate cortex in rats impairs alternation learning and retention. *J Comp Physiol Psychol*, 60(3), 353-359.
- Barlow JS. (1964). Inertial navigation as a basis for animal navigation. *J Theor Biol*, 6(1), 76-117.
- Becker JT, Walker JA, Olton DS. (1980). Neuroanatomical bases of spatial memory. *Brain Res*, 200(2), 307-320.
- Brown RW, Bardo MT, Mace DD, Phillips SB, Kraemer PJ. (2000). D-amphetamine facilitation of morris water task performance is blocked by eticlopride and correlated with increased dopamine synthesis in the prefrontal cortex. *Behav Brain Res*, 114(1-2), 135-143.
- Cain DP. (1997). Prior non-spatial pretraining eliminates sensorimotor disturbances and impairments in water maze learning caused by diazepam. *Psychopharmacology (Berl)*, 130(4), 313-319.
- Cain DP, Saucier D. (1996). The neuroscience of spatial navigation: focus on behavior yields advances. *Rev Neurosci*, 7(3), 215-231.

- Chen LL, Lin LH, Barnes CA, McNaughton BL. (1994a). Head-direction cells in the rat posterior cortex. II. Contributions of visual and ideothetic information to the directional firing. *Exp Brain Res*, 101(1), 24-34.
- Chen LL, Lin LH, Green EJ, Barnes CA, McNaughton BL. (1994b). Head-direction cells in the rat posterior cortex. I. Anatomical distribution and behavioral modulation. *Exp Brain Res*, 101(1), 8-23.
- Cho J, Sharp PE. (2001). Head direction, place, and movement correlates for cells in the rat retrosplenial cortex. *Behav Neurosci*, 115(1), 3-25.
- Clark RE, Broadbent NJ, Zola SM, Squire LR. (2002). Anterograde amnesia and temporally graded retrograde amnesia for a nonspatial memory task after lesions of hippocampus and subiculum. *J Neurosci*, 22(11), 4663-4669.
- Cooper BG, Mizumori SJ. (1999). Retrosplenial cortex inactivation selectively impairs navigation in darkness. *Neuroreport*, 10(3), 625-630.
- Cooper BG, Mizumori SJ. (2001). Temporary inactivation of the retrosplenial cortex causes a transient reorganization of spatial coding in the hippocampus. *J Neurosci*, 21(11), 3986-4001.
- Cooper BG, Manka TF, Mizumori SJ. (2001). Finding your way in the dark: the retrosplenial cortex contributes to spatial memory and navigation without visual cues. *Behav Neurosci*, 115(5), 1012-1028.
- Cottam C. (1948). Aquatic habits of the Norway rat. *J Mammal*, 29, 299.
- Darwin C. (1873). On the origin of certain instincts. *Nature (Lond)*, 7, 417-418.
- DeRenzi E (1982) *Disorders of Space Exploration and Cognition*. New York: Wiley.
- Domesick VB. (1969). Projections from the cingulate cortex in the rat. *Brain Res*, 12(2), 296-320.
- Ennaceur A, Neave N, Aggleton JP. (1997). Spontaneous object recognition and object location memory in rats: the effects of lesions in the cingulate cortices, the medial prefrontal cortex, the cingulum bundle and the fornix. *Exp Brain Res*, 113(3), 509-519.
- Galef GB, Jr. (1980). Diving for food: Analysis of a possible case of social learning in rats (*Rattus norvegicus*). *Journal of Comparative and Physiological Psychology*, 94, 416-425.



- Gandolfi C, Parisi V. (1972). Predazione su *Unio Pictorum* L. da parte del ratto, *Rattus norvegicus* (Berkenhout). *Acta Naturalia*, 8, 1-27.
- Geschwind N. (1965). Disconnexion syndromes in animals and man. I. *Brain*, 88(2), 237-294.
- Gonzalez CL, Kolb B, Whishaw IQ. (2000). A cautionary note regarding drug and brain lesion studies that use swimming pool tasks: partial reinforcement impairs acquisition of place learning in a swimming pool but not on dry land. *Behav Brain Res*, 112(1-2), 43-52.
- Harker KT, Whishaw IQ. (2002a). Impaired spatial performance in rats with retrosplenial lesions: importance of the spatial problem and the rat strain in identifying lesion effects in a swimming pool. *J Neurosci*, 22(3), 1155-1164.
- Harker KT, Whishaw IQ. (2002b). Place and matching-to-place spatial learning affected by rat inbreeding (Dark Agouti, Fischer 344) and albinism (Wistar, Spague-Dawley) but not domestication (wild rat vs Long-Evans, Fischer-Norway). *Behavioural Brain Research*, 134(1-2), 467-477.
- Harker KT, Whishaw IQ. (in Press). Impaired place navigation following both retrosplenial cortex lesions and cingulum bundle lesions in rats. *Hippocampus*.
- Hodges H. (1996). Maze procedures: the radial-arm and water maze compared. *Brain Res Cogn Brain Res*, 3(3-4), 167-181.
- Hoh TE, Cain DP. (1997). Fractionating the nonspatial pretraining effect in the water maze task. *Behav Neurosci*, 111(6), 1285-1291.
- Holscher C. (1999). Stress impairs performance in spatial water maze learning tasks. *Behav Brain Res*, 100(1-2), 225-235.
- Ino T, Inoue Y, Kage M, Hirose S, Kimura T, Fukuyama H. (2002). Mental navigation in humans is processed in the anterior bank of the parieto-occipital sulcus. *Neurosci Lett*, 322(3), 182-186.
- Jeltsch H, Cassel JC, Jackisch R, Neufang B, Greene PL, Kelche C, Hertting G, Will B. (1994). Lesions of supracallosal or infracallosal hippocampal pathways in the rat: behavioral, neurochemical, and histochemical effects. *Behav Neural Biol*, 62(2), 121-133.
- Katayama K, Takahashi N, Ogawara K, Hattori T. (1999). Pure topographical disorientation due to right posterior cingulate lesion. *Cortex*, 35(2), 279-282.

- Kolb B, Whishaw IQ. (1991). Mechanisms Underlying Behavioural Sparing After Neonatal Retrosplenial Cingulate Lesions in Rats: Spatial Navigation, Cortical Architecture, and Electroencephalographic Activity. *Brain Dysfunct*, 4, 75-92.
- Kolb B, Whishaw IQ (2001) *An introduction to brain and behavior*. New York: Worth.
- Kolb B, Sutherland RJ, Whishaw IQ. (1983). A comparison of the contributions of the frontal and parietal association cortex to spatial localization in rats. *Behav Neurosci*, 97(1), 13-27.
- Kolb B, Buhrmann K, McDonald R, Sutherland RJ. (1994). Dissociation of the medial prefrontal, posterior parietal, and posterior temporal cortex for spatial navigation and recognition memory in the rat. *Cereb Cortex*, 4(6), 664-680.
- Lashley KD. (1950). In Search of the Engram. *Symposia of the Society for Experimental Biology*, 4, 454-482.
- Li YJ, Low WC. (1997). Intraretrosplenial cortical grafts of fetal cholinergic neurons and the restoration of spatial memory function. *Cell Transplant*, 6(1), 85-93.
- Maaswinkel H, Jarrard LE, Whishaw IQ. (1999). Hippocampectomized rats are impaired in homing by path integration. *Hippocampus*, 9(5), 553-561.
- Maguire EA. (2001). The retrosplenial contribution to human navigation: a review of lesion and neuroimaging findings. *Scand J Psychol*, 42(3), 225-238.
- Maguire EA, Frackowiak RS, Frith CD. (1996). Learning to find your way: a role for the human hippocampal formation. *Proc R Soc Lond B Biol Sci*, 263(1377), 1745-1750.
- Maguire EA, Frackowiak RS, Frith CD. (1997). Recalling routes around London: activation of the right hippocampus in taxi drivers. *J Neurosci*, 17(18), 7103-7110.
- McNaughton BL, Barnes CA, Gerrard JL, Gothard K, Jung MW, Knierim JJ, Kudrimoti H, Qin Y, Skaggs WE, Suster M, Weaver KL. (1996). Deciphering the hippocampal polyglot: the hippocampus as a path integration system. *J Exp Biol*, 199(Pt 1), 173-185.
- Mechan AO, Moran PM, Elliott M, Young AJ, Joseph MH, Green R. (2002). A comparison between Dark Agouti and Sprague-Dawley rats in their behaviour on the elevated plus-maze, open-field apparatus and activity meters, and their response to diazepam. *Psychopharmacology (Berl)*, 159(2), 188-195.

- Mesulam MM. (1981). A cortical network for directed attention and unilateral neglect. *Ann Neurol*, 10(4), 309-325.
- Mesulam MM, Nobre AC, Kim YH, Parrish TB, Gitelman DR. (2001). Heterogeneity of cingulate contributions to spatial attention. *Neuroimage*, 13(6 Pt 1), 1065-1072.
- Meunier M, Bachevalier J, Mishkin M, Murray EA. (1993). Effects on visual recognition of combined and separate ablations of the entorhinal and perirhinal cortex in rhesus monkeys. *J Neurosci*, 13(12), 5418-5432.
- Mittelstaedt M-L, Mittelstaedt H. (1980). Homing by path integration in a mammal. *Naturwissenschaften*, 67, 566-567.
- Morris RGM. (1981). Spatial localization does not require the presence of local cues. *Learning and Motivation*, 12, 144-151.
- Morris RGM. (1984). Developments of a water-maze procedure for studying spatial learning in the rat. *J Neurosci Methods*, 11(1), 47-60.
- Morris RGM, Garrud P, Rawlins JN, O'Keefe J. (1982). Place navigation impaired in rats with hippocampal lesions. *Nature*, 297(5868), 681-683.
- Mufson EJ, Pandya DN. (1984). Some observations on the course and composition of the cingulum bundle in the rhesus monkey. *J Comp Neurol*, 225(1), 31-43.
- Neave N, Nagle S, Aggleton JP. (1997). Evidence for the involvement of the mammillary bodies and cingulum bundle in allocentric spatial processing by rats. *Eur J Neurosci*, 9(5), 941-955.
- Neave N, Lloyd S, Sahgal A, Aggleton JP. (1994). Lack of effect of lesions in the anterior cingulate cortex and retrosplenial cortex on certain tests of spatial memory in the rat. *Behav Brain Res*, 65(1), 89-101.
- Neave N, Nagle S, Sahgal A, Aggleton JP. (1996). The effects of discrete cingulum bundle lesions in the rat on the acquisition and performance of two tests of spatial working memory. *Behav Brain Res*, 80(1-2), 75-85.
- O'Keefe J. (1983). Two spatial systems in the rat brain--implications for the neural basis of learning and memory. *Prog Brain Res*, 58, 453-464.
- O'Keefe J, Nadel L (1978) *The hippocampus as a cognitive map*. Oxford: Clarendon Press.

- O'Keefe J, Burgess N, Donnett JG, Jeffery KJ, Maguire EA. (1998). Place cells, navigational accuracy, and the human hippocampus. *Philos Trans R Soc Lond B Biol Sci*, 353(1373), 1333-1340.
- Pakhomova AS, Akopian EV. (1985). [Direct connections between the hippocampus and the retrosplenial cortex in the rat]. *Neirofiziologiya*, 17(1), 102-107.
- Palmer MJ, Mumby DG, Cooper BG, Robison SE, Longstreet RR, Sutherland RJ. (1993). Medial prefrontal cortex and retrosplenial cortex make different contributions to memory for objects and places. *Society for Neuroscience Abstracts*, 19, 364.
- Pandya DN, Yeterian EH. (1984). Proposed neural circuitry for spatial memory in the primate brain. *Neuropsychologia*, 22(2), 109-122.
- Papez JW. (1937). A proposed mechanism of emotion. *Arch Neurol Psychiatr*, 38, 725-734.
- Pohl W. (1973). Dissociation of spatial discrimination deficits following frontal and parietal lesions in monkeys. *J Comp Physiol Psychol*, 82(2), 227-239.
- Prusky GT, West PW, Douglas RM. (2000). Behavioral assessment of visual acuity in mice and rats. *Vision Res*, 40(16), 2201-2209.
- Prusky GT, Harker KT, Whishaw IQ, Douglas RM. (2002). Variation in visual acuity within pigmented, and between pigmented and albino rat strains.
- Rauch TM, Welch DI, Gallego L. (1989). Hypothermia impairs performance in the Morris water maze. *Physiol Behav*, 46(2), 315-320.
- Riekkinen P, Jr., Kuitunen J, Riekkinen M. (1995). Effects of scopolamine infusions into the anterior and posterior cingulate on passive avoidance and water maze navigation. *Brain Res*, 685(1-2), 46-54.
- Saucier D, Hargreaves EL, Boon F, Vanderwolf CH, Cain DP. (1996). Detailed behavioral analysis of water maze acquisition under systemic NMDA or muscarinic antagonism: nonspatial pretraining eliminates spatial learning deficits. *Behav Neurosci*, 110(1), 103-116.
- Save E, Moghaddam M. (1996). Effects of lesions of the associative parietal cortex on the acquisition and use of spatial memory in egocentric and allocentric navigation tasks in the rat. *Behav Neurosci*, 110(1), 74-85.

- Scoville WB, Milner B. (1957). Loss of recent memory after bilateral hippocampal lesions. *Journal of Neurology, Neurosurgery and Psychiatry*, 20, 11-21.
- Seguinot V, Maurer R, Etienne AS. (1993). Dead reckoning in a small mammal: the evaluation of distance. *J Comp Physiol [A]*, 173(1), 103-113.
- Shapiro M. (2001). Plasticity, hippocampal place cells, and cognitive maps. *Arch Neurol*, 58(6), 874-881.
- Sutherland RJ, Dyck R. (1984). Place navigation by rats in a swimming pool. *Can J Psych*, 38, 322-347.
- Sutherland RJ, Rodriguez AJ. (1989). The role of the fornix/fimbria and some related subcortical structures in place learning and memory. *Behav Brain Res*, 32(3), 265-277.
- Sutherland RJ, Hoising JM (1993) Posterior cingulate cortex and spatial memory: A microlimnological analysis. In: *Neurobiology of Cingulate Cortex* (Vogt BA, Gabriel M, eds), pp 461-477. Boston: Birkhauser.
- Sutherland RJ, Whishaw IQ, Kolb B. (1980). Abnormalities in EEG and spatial performance following intrahippocampal injections of neurotoxins. *Soc Neurosci Abstr*, 6, 565.
- Sutherland RJ, Kolb B, Whishaw IQ. (1982). Spatial mapping: definitive disruption by hippocampal or medial frontal cortical damage in the rat. *Neurosci Lett*, 31(3), 271-276.
- Sutherland RJ, Whishaw IQ, Kolb B. (1983). A behavioural analysis of spatial localization following electrolytic, kainate- or colchicine-induced damage to the hippocampal formation in the rat. *Behav Brain Res*, 7(2), 133-153.
- Sutherland RJ, Whishaw IQ, Kolb B. (1988). Contributions of cingulate cortex to two forms of spatial learning and memory. *J Neurosci*, 8(6), 1863-1872.
- Sziklas V, Petrides M. (1998). Memory and the region of the mammillary bodies. *Prog Neurobiol*, 54(1), 55-70.
- Takahashi N, Kawamura M, Shiota J, Kasahata N, Hirayama K. (1997). Pure topographic disorientation due to right retrosplenial lesion. *Neurology*, 49(2), 464-469.
- Valenstein E, Bowers D, Verfaellie M, Heilman KM, Day A, Watson RT. (1987). Retrosplenial amnesia. *Brain*, 110(Pt 6), 1631-1646.

- Vanderwolf CH. (1969). Hippocampal electrical activity and voluntary movement in the rat. *Electroencephalogr Clin Neurophysiol*, 26(4), 407-418.
- Vann SD, Aggleton JP. (2002). Extensive cytotoxic lesions of the rat retrosplenial cortex reveal consistent deficits on tasks that tax allocentric spatial memory. *Behav Neurosci*, 116(1), 85-94.
- Vogt BA, Miller MW. (1983). Cortical connections between rat cingulate cortex and visual, motor, and postsubicular cortices. *J Comp Neurol*, 216(2), 192-210.
- Walker JA, Olton DS. (1979). Spatial memory deficit following fimbria-fornix lesions: independent of time for stimulus processing. *Physiol Behav*, 23(1), 11-15.
- Warburton EC, Aggleton JP, Muir JL. (1998). Comparing the effects of selective cingulate cortex lesions and cingulum bundle lesions on water maze performance by rats. *Eur J Neurosci*, 10(2), 622-634.
- Whishaw IQ. (1985a). Formation of a place learning-set by the rat: a new paradigm for neurobehavioral studies. *Physiol Behav*, 35(1), 139-143.
- Whishaw IQ. (1985b). Cholinergic receptor blockade in the rat impairs locale but not taxon strategies for place navigation in a swimming pool. *Behav Neurosci*, 99(5), 979-1005.
- Whishaw IQ (2000) The Septohippocampal System and Path Integration. In: *The Behavioral Neuroscience of the Septal Region* (Numan R, ed), pp 270-297. New York: Springer.
- Whishaw IQ, B.K. K. (1984). Decortication abolishes place but not cue learning in rats. *Behav Brain Res*, 11, 123-134.
- Whishaw IQ, Jarrard LE. (1995). Similarities vs. differences in place learning and circadian activity in rats after fimbria-fornix section or ibotenate removal of hippocampal cells. *Hippocampus*, 5(6), 595-604.
- Whishaw IQ, Jarrard LE. (1996). Evidence for extrahippocampal involvement in place learning and hippocampal involvement in path integration. *Hippocampus*, 6(5), 513-524.
- Whishaw IQ, Whishaw GE. (1996). Conspecific aggression influences food carrying: Studies on a wild population of *Rattus norvegicus*. *Aggress Behav*, 22, 47-66.

- Whishaw IQ, Maaswinkel H. (1998). Rats with fimbria-fornix lesions are impaired in path integration: a role for the hippocampus in "sense of direction". *J Neurosci*, 18(8), 3050-3058.
- Whishaw IQ, Kolb B, Sutherland RJ (1983) The analysis of behavior in the laboratory rat. In: *Behavioral approaches to brain research* (Robinson TE, ed), pp 237-264. New York: Oxford University Press.
- Whishaw IQ, McKenna JE, Maaswinkel H. (1997). Hippocampal lesions and path integration. *Curr Opin Neurobiol*, 7(2), 228-234.
- Whishaw IQ, Haun F, Kolb B (1999) Analysis of behavior in laboratory rodents. In: *Modern techniques in neuroscience research* (Windhorst U, Johansson H, eds), pp 1243-1275. New York: Springer.
- Whishaw IQ, Maaswinkel H, Gonzalez CL, Kolb B. (2001). Deficits in allothetic and idiothetic spatial behavior in rats with posterior cingulate cortex lesions. *Behav Brain Res*, 118(1), 67-76.
- Winer BJ (1962) *Statistical Principles in Experimental Design*. New York: McGraw-Hill.
- Wozniak DF, Brosnan-Watters G, Nardi A, McEwen M, Corso TD, Olney JW, Fix AS. (1996). MK-801 neurotoxicity in male mice: histologic effects and chronic impairment in spatial learning. *Brain Res*, 707(2), 165-179.
- Wyss JM, Van Groen T. (1992). Connections between the retrosplenial cortex and the hippocampal formation in the rat: a review. *Hippocampus*, 2(1), 1-11.
- Zilles K, Wree A (1995) Cortex: Areal and Laminar Structure. In: *The Rat Nervous System*, 2nd Edition (Paxinos G, ed), pp 649-685. San Diego, CA: Academic Pres.