

**EXPLORING THE POTENTIAL FOR CONTROL OF EURASIAN
WATERMILFOIL BY THE MILFOIL WEEVIL IN CHRISTINA LAKE,
BRITISH COLUMBIA**

CARA FREW
Bachelor of Science, University of Lethbridge, 2003

A Thesis
Submitted to the School of Graduate Studies
of the University of Lethbridge
in Partial Fulfilment of the
Requirements for the Degree

MASTER OF SCIENCE

Department of Geography
University of Lethbridge
LETHBRIDGE, ALBERTA, CANADA

© Cara Frew, 2016

EXPLORING THE POTENTIAL FOR CONTROL OF EURASIAN WATERMILFOIL
BY THE MILFOIL WEEVIL IN CHRISTINA LAKE, BRITISH COLUMBIA

CARA FREW

Date of Defence: October 12, 2016

Dr. Dan Johnson Supervisor	Professor	Ph.D.
-------------------------------	-----------	-------

Dr. Craig Coburn Thesis Examination Committee Member	Associate Professor	Ph.D.
---	---------------------	-------

Dr. Joseph Rasmussen Thesis Examination Committee Member	Professor	Ph.D.
---	-----------	-------

Dr. Stefan Kienzle Chair, Thesis Examination Committee	Professor	Ph.D.
---	-----------	-------

ABSTRACT

Aquatic invasive plants present a growing risk to the environment and the economy. One of the most problematic invasive plants found in North American waterbodies is Eurasian watermilfoil, *Myriophyllum spicatum*. Eurasian watermilfoil was inadvertently introduced into Christina Lake, British Columbia, Canada, in the early 1980's. Physical control methods have been utilized since the plant was first identified in the Lake, but regular intensive management is required to meet control objectives. Variable success has been reported in Ontario lakes and waterbodies in the United States using the milfoil weevil, *Euhrychiopsis lecontei* as a biological control agent. Field sampling in Christina Lake indicated that the milfoil weevil is not currently present, or is present at numbers below detection. As an introductory stage of a potential biological control program, a Christina Lake-specific simulation model was developed to evaluate the expected response of milfoil growth to different weevil augmentation scenarios. Results of the model indicate that control of the sites most impacted by Eurasian watermilfoil could be achieved with a weevil augmentation rate of one weevil per square metre.

ACKNOWLEDGEMENTS

I would like to acknowledge the following individuals who played an important role in the completion of this thesis and to whom I will be forever grateful. I want to express sincere gratitude to my supervisor, Professor Dan Johnson for his support through all stages of this thesis. I am grateful for the broadened perspective his leadership has given to me, not only in the area of science and research, but also of humanity. I am thankful to the members of my Supervisory Committee, Craig Coburn and Joseph Rasmussen, for their advice and direction. I want to acknowledge members of the Geography Department, Jim Byrne and Ryan MacDonald for their support, advice and encouragement during the program. This thesis would not have been possible without financial and in-kind support from the Regional District of Kootenay Boundary; Alan Stanley and Grace McGregor – thank you. Heather Ling’s contribution to the field work portion of this thesis went above and beyond, and for this, I am especially grateful. The Christina Lake milfoil control dive team, especially Andrew Gillmore and Chad Freeman, who provided an insight to the underwater world. I want to thank Martin Christman for coordinating a work-space in the field and providing boat access to the lake. Barbra Stewart of the Christina Lake Stewardship Society was a wealth of local knowledge and I am grateful for her direction and advice.

DEDICATION

This thesis is dedicated to my family. To my parents Paul and Sue Adrain, I will forever be in admiration of your integrity, honesty and perseverance. To my sister Suzanne and her husband Rod, whose support is appreciated beyond words. To my brother Pat and his wife Morgan, whose selfless devotion to family is an inspiration. To Rob and Stacia Frew, who have opened their doors and their hearts to me. To my husband Kevin Frew, who is a perpetual source of support and encouragement.

TABLE OF CONTENTS

CHAPTER 1– THE PROGRESSION OF EURASIAN WATERMILFOIL BIOLOGICAL CONTROL USING THE MILFOIL WEEVIL.....	1
1.1 Introduction.....	1
1.2 Eurasian watermilfoil biological control	7
1.2.1 Natural Eurasian watermilfoil declines.....	8
1.2.2 Invertebrate herbivores as potential biological control agents	14
1.2.3 Laboratory experiments	22
1.2.4 Experimental milfoil weevil releases.....	25
1.3 Commercial milfoil weevil augmentation programs	27
1.3.1 Augmentation programs in the United States	28
1.3.2 Augmentation programs in Canada	29
CHAPTER 2–SIMULATION MODEL	38
2.1 Conceptual model	39
2.1.1 Temperature	41
2.1.2 Irradiance	43
2.1.3 Carbon source and nutrients.....	43
2.1.4 Non-structural carbohydrates.....	44
2.1.5 Autofragmentation	44
2.1.6 Milfoil weevil larva.....	45
2.2 Model development	46
2.2.1 Eurasian watermilfoil biomass accumulation during periods of active photosynthesis.....	47
2.2.2 Biomass loss due to respiration and autofragmentation	48
2.2.3 Early season biomass accumulation using non-structural carbohydrates	49
2.2.4 Biomass loss due to feeding and burrowing action of milfoil weevil larvae.....	50
2.2.5 Milfoil weevil larvae population.....	50
2.3 Data used as model inputs.....	53
2.3.1 Surface water temperature	53
2.3.2 Irradiance	54
2.3.3 Water clarity.....	56
2.3.4 Plant height	57
2.3.5 Milfoil stem and biomass density	58
2.3.6 Non-structural carbohydrates.....	59
2.4 Results.....	64
2.4.1 Weevil augmentation scenarios	68
2.5 Assumptions.....	70

CHAPTER 3–FIELD DATA USED FOR SIMULATION MODEL.....	72
3.1 General description of the study site.....	72
3.2 Sources of data used for the simulation model	73
3.2.1 Eurasian watermilfoil coverage	74
3.2.2 Eurasian watermilfoil biomass and stem length (height).....	82
3.2.3 Current milfoil weevil population in Christina Lake.....	87
3.2.4 Surface water temperature	95
3.2.5 Water depth.....	96
3.2.6 Solar radiation.....	99
3.3 Conclusion	99
REFERENCES	103
APPENDICES	114

LIST OF TABLES

Table 1. Summary of documented cases of natural Eurasian watermilfoil declines in North America	13
Table 2. Comparison of three invertebrate herbivores for the purpose of biological control of Eurasian watermilfoil	21
Table 3. Relative change in Eurasian watermilfoil density after treatment with milfoil weevils in eight Ontario lakes, 2011 to 2014. Adapted from EnviroScience Inc. 2011, 2012, 2013, 2014.....	34
Table 4. Frequency of success and failure for weevil treatment and control groups.....	36
Table 5. Degree-days and base development rates for each stage of <i>Euhrychiopsis lecontei</i> development (Mazzei et al., 1999)	51
Table 6. Christina Lake, B.C. Secchi Disk Depth (SDD) from the South End sampling station (0200078)	57
Table 7. Model input for Eurasian watermilfoil height (h) for Christina Lake, 2014	58
Table 8. Mean stem (δ_w) and biomass (P_s) density for each infestation level in Christina Lake BC., 2014.....	59
Table 9. Parameters, variables, constants and values used for the simulation model, adapted from Miller et al., 2011.....	61
Table 10. Model output for maximum biomass under different milfoil growth rate values	67
Table 11. Model output for maximum milfoil biomass accumulation and date of biomass crash for weevil augmentation scenarios ranging from 0 to 5 adult weevils per square metre.....	70
Table 12. Datasets used for development of the simulation model	74
Table 13. Classification of Eurasian watermilfoil control areas by infestation level	77
Table 14. Cumulative areas of the Eurasian watermilfoil infestation levels within the Eurasian watermilfoil control zone of Christina Lake, B.C. from 2012 to 2014.....	81

Table 15. Average biomass of Eurasian watermilfoil plants in Christina Lake, B.C. from May to August 2013.....	85
Table 16. Average milfoil stem length over the course of the 2014 growing season in Christina Lake, BC.....	87
Table 17. Observation of insect herbivory at Eurasian watermilfoil control sites on Christina Lake, BC.....	90
Table 18. Mean daily global insolation (NRC 2014) for Christina Lake, B.C.	99

LIST OF FIGURES

Figure 1. Finely dissected leaves, giving Eurasian watermilfoil a feathery appearance (Lovell, 2009)	3
Figure 2. Characteristic dense growth of Eurasian watermilfoil resulting in barriers to recreation activities and altering fish habitat (Evans, 2007).....	4
Figure 3. Number of Eurasian watermilfoil plants hand-harvested by SCUBA divers from Christina Lake, B.C., during the period of 1986 to 2014 (Lund & Caswell, 2009; Haberstock, 2006; RDKB, 2012, 2013, 2014).....	5
Figure 4. Documented natural Eurasian watermilfoil declines and range of <i>E. lecontei</i> in North America, adapted from Creed, 1998.....	9
Figure 5. Adult milfoil weevil, <i>Euhrychiopsis lecontei</i> (Iowa State University, 2016)	19
Figure 6. Locations of commercial biological control programs in Canada, using the milfoil weevil as a control agent for Eurasian watermilfoil (EnviroScience Inc., 2011, 2012, 2013a, 2013b, 2014).....	30
Figure 7. Relative change in Eurasian watermilfoil density after milfoil weevil augmentation in eight Ontario lakes between the period of 2011 and 2014 (adapted from EnviroScience Inc.)	35
Figure 8. Conceptual model showing the main drivers that influence biomass accumulation of Eurasian watermilfoil as it relates to a weevil augmentation.....	41
Figure 9. Eurasian watermilfoil biomass model structure	46
Figure 10. Milfoil weevil lifecycle model structure	52
Figure 11. Mean daily surface water temperature, Christina Lake, B.C. south littoral zone, years 2014 and 2015.....	54
Figure 12. Calculated light energy available for photosynthesis ($\mu\text{Em}^{-2}\text{s}^{-1}$) above water surface (I_s) and just below water surface (I_o).....	55
Figure 13. A standard Secchi disk for use in freshwater environments (UMCES, 2016) .	56
Figure 14. Modeling software output, milfoil biomass prior to adjusting model parameter values	65
Figure 15. Response of milfoil biomass accumulation under milfoil base growth rates varying from 0.05 to 0.20 1 day ⁻¹	66
Figure 16. Model output for biomass accumulation after parameter values were manipulated to represent conditions of Christina Lake	68
Figure 17. Milfoil biomass response to different weevil augmentation scenarios (0, 1, 3 and 5 adult weevils m ⁻²).....	69
Figure 18. RDKB Eurasian watermilfoil control site distribution, Christina Lake, B.C. (2014, 2015).....	76

Figure 19. Infestation levels observed at the Eurasian watermilfoil control sites in the south end of Christina Lake, B.C. by level of diver control effort for the years 2012, 2013 and 2014.....	79
Figure 20. Infestation levels observed at the Eurasian watermilfoil control sites in the north end of Christina Lake B.C. by level of diver control effort for the years 2013 and 2014.....	80
Figure 21. Proportion of the levels of Eurasian watermilfoil infestations within the control zone of Christina Lake, B.C. from 2012 to 2014.....	82
Figure 22. Eurasian watermilfoil sample collection locations for biomass analysis, Christina Lake, B.C.....	84
Figure 23. Average biomass (dry weight per stem) of Eurasian watermilfoil plants in Christina Lake, B.C. from May to August 2014.....	86
Figure 24. Locations of Eurasian watermilfoil plants that were inspected for evidence of invertebrate herbivore activity	89
Figure 25. Adhesive insect trap locations, southeast shoreline of Christina Lake, B.C. ...	93
Figure 26. Location of leaf litter/soil samples collected from the shoreline of Christina Lake, B.C. on November 8, 2013	95
Figure 27. Bathymetric map of Christina Lake, B.C., adapted from the Province of British Columbia, 1952.....	98

CHAPTER 1– THE PROGRESSION OF EURASIAN WATERMILFOIL BIOLOGICAL CONTROL USING THE MILFOIL WEEVIL

1.1 Introduction

Throughout the course of history, humans have either unintentionally or purposefully transported species from their native environment to new habitats. The recent advances in travel facilitate the transport of plant and animal species, many of them becoming invasive once established. In Canada, invasive plants in particular present a growing risk to the environment and the economy, while the threat of new introductions continues to increase. Billions of dollars are lost in Canada annually as a result of invasive species, with estimated losses of \$20 billion to the forest sector, \$7 billion related to aquatic invasive species and \$2.2 billion to the agricultural sector (Environment Canada, 2010). Climate change and other environmental factors such as the eutrophication of waterbodies may favour the establishment and spread of terrestrial and aquatic invasive species (Government of Canada, 2008).

In aquatic systems, invasive species establishment has led to economic losses resulting from decreased quantity and quality of recreational activities, decreased agricultural production, increased cost of electricity generation, and degraded land use values (Rockwell, 2003; Newroth & Maxnuk, 1993; Lovell & Stone 2005). Because the problem is multifaceted and the costs related to impaired ecological function are difficult to assess, the financial implications of preventing and controlling invasive species are not well understood (Lovell & Stone, 2005; Rockwell, 2003). Oden and Tamayo (2014) constructed a model in an effort to quantify lakefront property value losses in Washington State as a result of Eurasian watermilfoil infestation. They found a significant negative

effect on property values, where home prices dropped 19% with Eurasian watermilfoil infestations.

The impact that aquatic invasive plants have on recreation activities is especially important in areas that depend on tourism. Such is the case in British Columbia (BC), where roughly one in 15 individuals in the labour market is employed in the tourism sector (Province of BC, 2012). In a study of aquatic invasive plant management programs in 16 B.C. lakes, Newroth & Maxnuk (1993) estimated that the annual recreational benefit of the control programs was \$85 million.

Eurasian watermilfoil, *Myriophyllum spicatum*, is an aquatic plant native to regions of Europe, Asia and Northern Africa (Smith & Barko, 1990) and since its accidental introduction to North America in the 1940's has spread throughout the United States and Canada. Smith & Barko (1991) describe it as "one of the most troublesome submersed aquatic plants in North America." When established in an area, it can form dense beds that significantly alter the values of an ecosystem.

Eurasian watermilfoil can be identified by its tall, slender growth form, oftentimes exceeding heights of 3 m. The finely dissected leaves are concentrated in the upper portion of the plant, and when viewed underwater, the plant takes on a feathery appearance (Figure 1). Physiological adaptations that allow Eurasian watermilfoil to successfully outcompete native plants in many situations include the utilization of non-structural carbohydrates early in the season for rapid stem elongation, the formation of lateral stems as the plant approaches the water surface, and its vegetative reproductive strategy. Early rapid stem elongation and lateral branching effectively limits light resources to slower growing plants. Vegetative reproduction in Eurasian watermilfoil occurs either by the formation of new stems from the parent root mass, or by stem

fragmentation. Stem fragmentation occurs once or twice in a growing season, depending on the site characteristics. Rooting structures form on the upper part of the stem prior to the stem releasing from the parent plant. The plant segments float on water currents then drop to the substrate where they can form new colonies (Grace & Wetzel, 1978).



Figure 1. Finely dissected leaves, giving Eurasian watermilfoil a feathery appearance (Lovell, 2009)

From a recreational view, the milfoil beds form physical barriers to watercraft and fishing methods (Figure 2), in addition to altering the composition of fish communities. Water activities such as swimming are also severely limited in areas with dense Eurasian watermilfoil growth. Ecological impacts of Eurasian watermilfoil infestations include the suppression of native vegetation, macroinvertebrates, fish spawning and fish growth (Johnson and Blossey, 2002). Eurasian watermilfoil can also alter ecosystem processes, reduce water quality, reduce dissolved oxygen, and change water temperature (Eiswerth, Donaldson & Johnson, 2000; Capers, Selsky, Bugbee & White, 2009).



Figure 2. Characteristic dense growth of Eurasian watermilfoil resulting in barriers to recreation activities and altering fish habitat (Evans, 2007)

Eurasian watermilfoil was first identified in the B.C. in 1970, when it was discovered in the Vernon Arm of Okanagan Lake (Okanagan Basin Water Board, 2009). The plant has since spread to all the main lakes in the Okanagan, Shuswap Lake, Mara Lake, Christina Lake, Champion Lakes, water bodies in the Lower Mainland, and isolated locations on Vancouver Island (B.C. Ministry of Environment, 2011). The Invasive Alien Plant Program (2012) also identifies numerous locations throughout Kootenay Lake and downstream, in both the Columbia River (near Castlegar) and the Kootenai River (near the US border).

Eurasian watermilfoil was first identified in Christina Lake in 1985. In 1986, an intensive survey identified Eurasian watermilfoil at two sites from which 14,000 stems were subsequently controlled by hand removal and bottom barrier installation. Over the next seven years, despite control efforts, annual survey results illustrate the expansion of the plant, with presence observed at 62 sites by 1993 (Cavanagh, 1994). Figure 3 details

the annual number of Eurasian watermilfoil plants hand-harvested by SCUBA divers from Christina Lake, showing an increase in harvested plants over time.

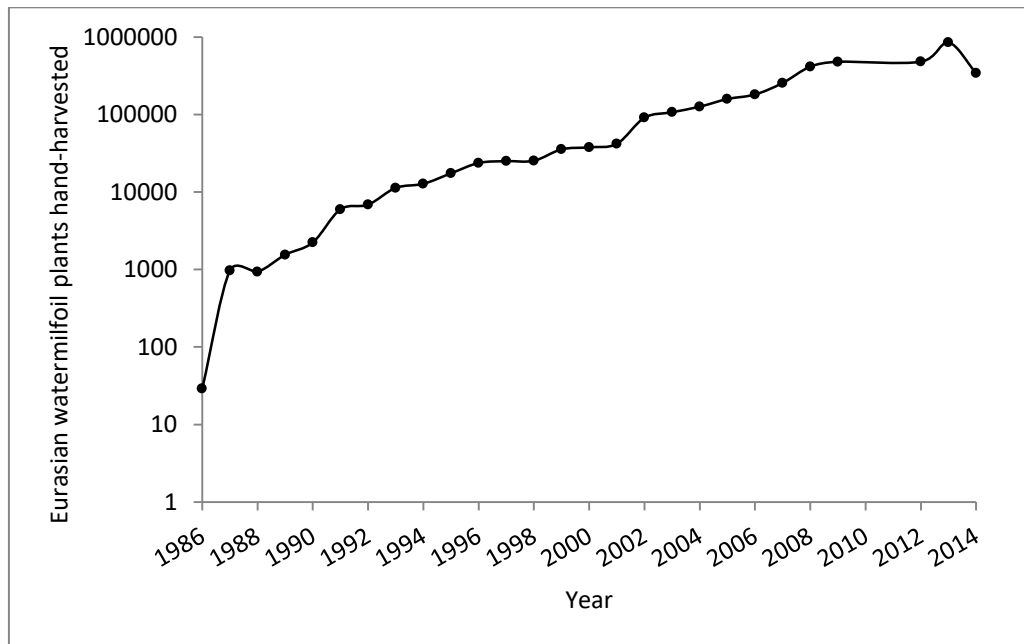

Figure 3. Number of Eurasian watermilfoil plants hand-harvested by SCUBA divers from Christina Lake, B.C., during the period of 1986 to 2014 (Lund & Caswell, 2009; Haberstock, 2006; RDKB, 2012, 2013, 2014)

Eurasian watermilfoil in Christina Lake has the potential to impact the fishery in a number of ways. If biomass is sufficient, milfoil beds provide refuge for fish. Smaller prey fish species using the refuge may result in reduced predator success of piscivorous fish, bass for example. Alternatively, predators such as the Northern Pikeminnow take refuge in dense stands of Eurasian watermilfoil, potentially increasing predation and reducing the success of native salmonids (COSEWIC, 2003).

Another concern relating to fish habitat is the potential for Eurasian watermilfoil to invade spawning beds of native salmonids. In the Okanagan, Eurasian watermilfoil does not directly impact the spawning habitat of Kokanee (*Oncorhynchus nerka*), as the characteristics of the spawning substrate are not conducive to Eurasian watermilfoil

establishment (Okanagan Basin Water Board, 2009). However, research on Cultus Lake, B.C. indicates that Eurasian watermilfoil can be detrimental to Sockeye (*Oncorhynchus nerka*) populations because the dense growth prevents access to spawning sites (Cultus Sockeye Recovery Team, 2005)

Throughout North America, numerous methods including mechanical, chemical and biological, have been employed in Eurasian watermilfoil control programs with varying degrees of success. Most treatment methods are costly and, particularly in the case of chemical control, rejected by the general public in many locations. Environmental damage in the form of substrate disruption (from dredges or rototillers) and impact to native species can result from mechanical treatment options.

Biological control, utilizing “natural enemies to reduce the damage caused by noxious organisms to tolerable levels,” (DeBach & Rosen, 1991) has been utilized for controlling a variety of terrestrial and aquatic weeds (Creed & Sheldon, 1995). Although the use of native insects as control agents for exotic weeds has been ineffective in some cases, many documented Eurasian watermilfoil declines in the United States have been found to be associated with the presence of the native milfoil weevil, *Euhrychiopsis lecontei* (Dietz) (Creed & Sheldon 1995; Sheldon, 1997; Lillie 1996; Creed 1998).

Extensive effort has been devoted to the control of Eurasian watermilfoil in Christina Lake since it was discovered in 1985. Control methods including mechanical harvesting, utilization of dive teams for hand removal and the installation of bottom barriers are methods that have been employed. Annual surveys have documented the distribution of the plant, control methods employed and results of treatment. Despite persistent control measures, the distribution and density of Eurasian watermilfoil in Christina Lake has increased over time (Wallis & Haberstock, 1988; Retzer &

Haberstock, 1989, 1990, 1991, 1993; Dale & Haberstock, 1992; Haberstock, 2004, 2005, 2006; Caswell, 2010).

The biological control option is being considered for Christina Lake and the focus of this thesis is to explore the suitability of Christina Lake for a weevil augmentation program. The following questions will be addressed in this paper:

- 1) Is the milfoil weevil the best option for biological control of Eurasian watermilfoil in Christina Lake?
- 2) Have weevil augmentation programs been successful at reducing Eurasian watermilfoil growth in other areas of North America?
- 3) Will the surface water temperature, irradiance and milfoil characteristics of Christina Lake limit the success of a weevil augmentation program?
- 4) What is the expected response of milfoil biomass in Christina Lake under different weevil augmentation rates?

1.2 Eurasian watermilfoil biological control

Advances in biological control of Eurasian watermilfoil using *Euhrychiopsis lecontei* (Coleoptera: Curculionidae) are described in this chapter, from the first observed natural milfoil declines to the commercial rearing and augmentation of waterbodies across the United States and Canada. Augmentation refers to the addition of milfoil weevils to a waterbody with an existing population of milfoil weevils, thereby “augmenting” the population. This chapter also discusses the traits that make the milfoil weevil (*E. lecontei*) a suitable biocontrol agent and compares them to traits of other invertebrate herbivores that have been associated with Eurasian watermilfoil declines. Results of milfoil weevil augmentation programs in the United States and Canada are summarized and discussed where data are available.

1.2.1 Natural Eurasian watermilfoil declines

Since the 1940's, when Eurasian watermilfoil was first positively identified in North America near Chesapeake Bay (Couch & Nelson, 1986), it has rapidly colonized new waterbodies throughout North America (Madsen, 1998). Herbarium records prior to 1950 indicate its presence in the District of Columbia, Ohio, Arizona and California (Smith & Barko, 1990). By the late 1990's, Eurasian watermilfoil was found in 44 states in the U.S. (Madsen, 1998), and three Canadian Provinces (Creed, 1998). The current distribution of Eurasian watermilfoil in the U.S. includes all continental states with the exception of Rhode Island and Wyoming (EDDMapS, 2015). In Canada, the current distribution remains in three provinces; Ontario, British Columbia, and Quebec (USDA, 2015).

Beginning in the 1960's, drastic declines in milfoil abundance were observed in waterbodies that had previously been subject to abundant Eurasian watermilfoil growth (Creed, 1998). These stand-level "natural" collapses of milfoil that could not be attributed to management activities spurred research into the cause of the declines. Figure 4, adapted from Creed (1998), outlines the locations of these documented natural Eurasian watermilfoil declines.

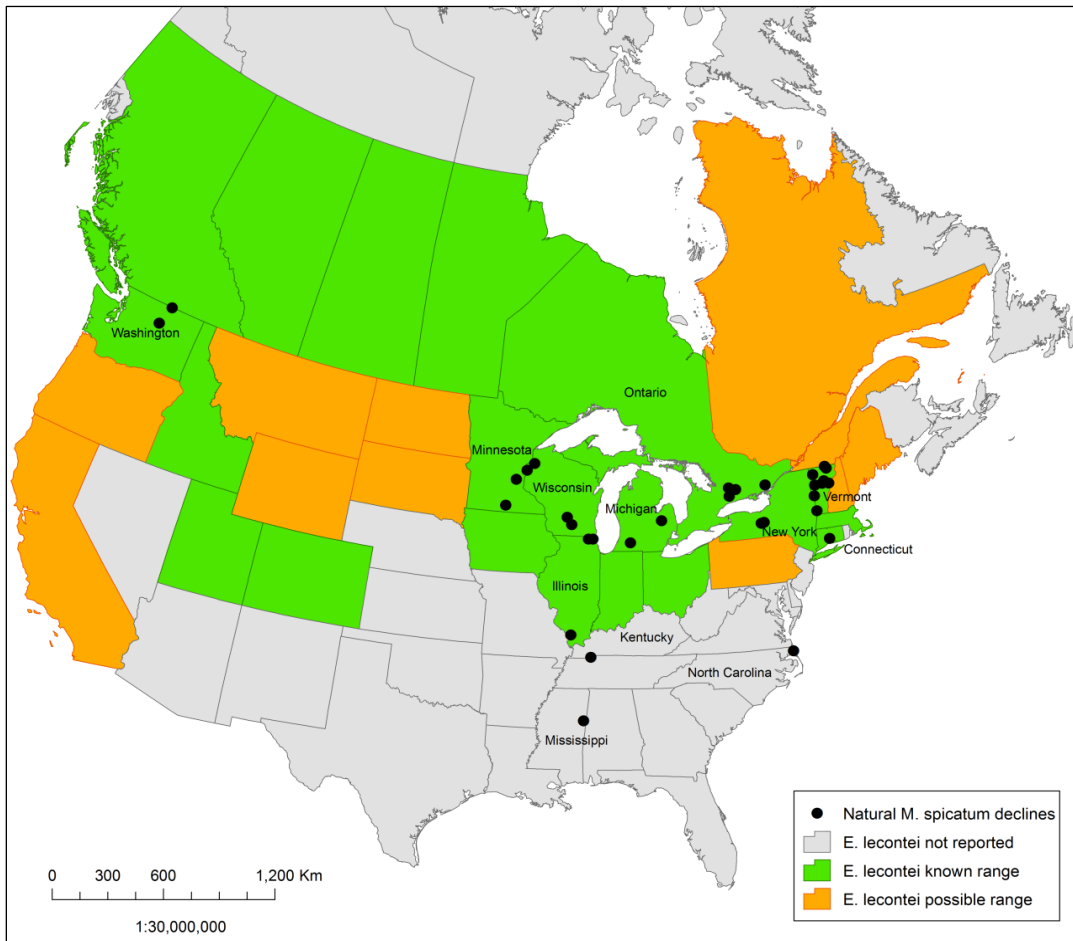

Figure 4. Documented natural Eurasian watermilfoil declines and range of *E. lecontei* in North America, adapted from Creed, 1998.

One of the first documented natural Eurasian watermilfoil declines occurred in Lake Wingra, Wisconsin. Carpenter (1980) studied the lake extensively, documenting the establishment of Eurasian watermilfoil, and subsequent reduction in Eurasian watermilfoil abundance. Factors considered by Carpenter (1980) included potential toxin accumulation in Eurasian watermilfoil, the effects of vegetation control measures, climatic changes, nutrients, epiphytic algae, macrophyte competition, and pathogens. Carpenter (1980) concluded that no single factor was responsible for the observed Eurasian watermilfoil decline in Lake Wingra, but was likely due to a combination of factors including nutrient availability, epiphytes, competitors, and parasites or pathogens.

Herbivory by insects was not explored by Carpenter as a factor that may have contributed to the Eurasian watermilfoil decline.

Following Carpenter's work, Creed and Sheldon (1992, 1993, 1994) studied a natural decline of Eurasian watermilfoil in Brownington Pond, Vermont. A two-year monitoring program was initiated in 1990, during which the boundaries of the infestation were mapped, plant biomass was determined and associated invertebrate population studies were conducted. Evidence of herbivory on the stems and leaves of Eurasian watermilfoil and the presence of the milfoil weevil and the water veneer moth, *Acentria ephemerella* (formerly *Acentropus niveus*; Lepidoptera: Pyralidae) in the milfoil beds led the researchers to hypothesize that these two invertebrate herbivores were responsible for the observed reduction of Eurasian watermilfoil abundance (Creed et al., 1992). Creed and Sheldon found that the primary mechanism responsible was damage to the stem structure of the milfoil, resulting in loss of buoyancy and subsequent collapse of the plants in the water column. Investigations determined the cause of stem damage to be milfoil weevil larvae burrowing into the stem while feeding.

Concurrently, Painter and McCabe (1988) were investigating the reduced abundance of Eurasian watermilfoil in the Kawartha Lakes, Ontario, specifically focusing on the role of sediment. They found no correlation between sediment chemistry variables (pore-water, redox potential, and geochemistry) and milfoil abundance in the almost 50 study sites. Evidence of heavy herbivore feeding was observed during the course of the investigation at sites in Lake Scugog, Ontario. In this case, the grazing larvae were identified as *A ephemerella*, the aquatic water veneer moth native to Europe. Painter and McCabe (1998) concluded that the decline in Eurasian watermilfoil abundance observed

in the Kawarthas' Buckhorn and Scugog Lakes during 1986 were attributable to *A. ephemera* larvae.

Aquatic herbivores were also the focus of research by Johnson, Van Dusen, Toner and Hairston (2000) who studied the macrophyte community of Cayuga Lake, New York for over 12 years. The vegetation community in shallow areas of the lake had been dominated by Eurasian watermilfoil until a natural decline in relative biomass was observed in the 1980's (Johnson et al., 2000; Gross, Johnson & Hairston, 2001). Eurasian watermilfoil biomass peaked in 1974 (736 g dry matter (DM) m⁻²) (Peverley, 1979) following a lake-wide disturbance in 1973 where flood waters from a tropical storm deposited sediment over macrophytes during the growth period (Johnson et al., 2000). A second Eurasian watermilfoil biomass peak occurred in 1988, with a value of 325 g DM m⁻² (Johnson et al., 2000). From 1989 to 1998, a steady decline in Eurasian watermilfoil biomass was observed; the 1998 biomass value was 0.34 g DM m⁻² (Johnson et al., 2000).

The milfoil weevil and water veneer moth (*A. ephemera*) were suspected of playing a role in the observed Eurasian watermilfoil decline in Cayuga Lake, New York. Although a generalist herbivore, stem damage to Eurasian watermilfoil from feeding activities of the water veneer moth can cause collapse of milfoil beds at high densities, consistent with the observations from Cayuga Lake (Johnson et al., 2000). Although the water veneer moth was found to be the dominant herbivore, the milfoil weevil was also associated with Eurasian watermilfoil in the lake. Studies by Johnson et al. (2000) explored the relationship between Eurasian watermilfoil, the herbivorous milfoil weevil and the water veneer moth in five New York lakes. Johnson et al. (2000) suggested that competition for resources is likely occurring between the milfoil weevil and the water veneer moth.

Similar studies occurred in Fish Lake, Wisconsin. Eurasian watermilfoil was introduced into the lake in the 1960's and by the early 1990's had represented 90% of the macrophyte community. A fisheries study was occurring in Fish Lake, when Lillie and Helsel (1997) documented a dramatic reduction in the density and extent of coverage of Eurasian watermilfoil over a course of eight years. Lillie (2000) assessed Eurasian watermilfoil stem damage and invertebrate abundance in the lake over a course of four years, from 1995-1998. Lillie found that Eurasian watermilfoil stem damage was positively correlated with milfoil weevil densities. Milfoil weevil densities fluctuated over the course of the study and were related to annual variation in Eurasian watermilfoil density, leading Lillie (2000) to conclude that the Eurasian watermilfoil "crash" observed in 1994 was related to the milfoil weevil.

In Cenaiko Lake, Minnesota, Newman and Biesboer (2000) investigated another natural decline of Eurasian watermilfoil. They were interested in the relationship between Eurasian watermilfoil density and milfoil weevil population in the lake over a five-year period. Early in the study, Eurasian watermilfoil biomass declined significantly over three months. High natural densities of milfoil weevil were found to be associated with the decline. Results from their study suggest that the milfoil weevil is capable of reaching densities sufficient to cause Eurasian watermilfoil to decline naturally, with no anthropogenic intervention (Newman, 1996; Newman & Beisoboer, 2000).

The cases of natural Eurasian watermilfoil declines in North America described in this Section are summarized in Table 1.

Table 1. Summary of documented cases of natural Eurasian watermilfoil declines in North America

Location	Research focus	Suspected cause of decline	Reference(s)
Lake Wingra, Wisconsin	Toxin accumulation, vegetation control, climate change, nutrients, epiphytic algae, macrophyte competition, plant pathogens	No single factor responsible; likely combination of factors including nutrient availability, epiphytes, competitors and parasites/pathogens	Carpenter (1980)
Brownington Pond, Vermont	Herbivory by invertebrates	Herbivory by <i>Euhrychiopsis lecontei</i> and <i>Acentria ephemerella</i>	Creed & Sheldon (1992, 1993, 1994)
Kawartha Lakes, Ontario	Sediment chemistry, herbivory by invertebrates	Herbivory by <i>A. ephemerella</i>	Painter & McCabe (1988)
Cayuga Lake, New York	Herbivory by invertebrates	Herbivory by <i>A. ephemerella</i> and stem damage from <i>E. lecontei</i>	Johnson et al. (1998, 2000)
Fish Lake, Wisconsin	Herbivory by invertebrates	Stem damage from <i>E. lecontei</i>	Lillie & Helsel (1997)
Cenaiko Lake, Minnesota	<i>E. lecontei</i> population	<i>E. lecontei</i>	Newman & Biesboer (2000), Newman (1996)

The scope of early work by Carpenter (1980) investigating the decline in Lake Wingra, Wisconsin was broad, assessing many variables other than herbivory by invertebrates. Later studies focused on invertebrate herbivores, mainly *A. ephemerella* and *E. lecontei*, found relationships between these herbivores and milfoil declines (Creed

& Sheldon, 1992, 1993, 1994; Painter & McCabe, 1988; Johnson et al., 1998, 2000).

Evidence to support the theory that natural declines of Eurasian watermilfoil in Fish Lake and Cenaiko Lake, Wisconsin were caused by *E. lecontei* was presented by Lillie and Helsel (1997) and Newman and Biesboer (2000).

1.2.2 Invertebrate herbivores as potential biological control agents

Researchers investigating the natural Eurasian watermilfoil declines identified the likely agents as herbivore invertebrates, most often either the water veneer moth or the milfoil weevil (Creed et al., 1992; Creed & Sheldon, 1993, 1994; Painter & McCabe, 1988; Johnson et al., 1998, 2000; Lille, 2000; Lillie & Helsel, 1997). A third aquatic invertebrate has also been identified as a potential biological control agent, the milfoil midge, *Cricotopus myriophylli* (Diptera: Chironomidae).

1.2.2.1 The milfoil midge, *Cricotopus myriophylli*

Limited research has been conducted on the milfoil midge, *C. myriophylli*, a specialist herbivore (University of Minnesota, 2015) found to be associated with Eurasian watermilfoil declines in British Columbia (Newman, 2004; MacRae, Winchester & Ring, 1990; Johnson & Blossey, 2002). Milfoil midge larvae establish and feed on the apical tip of milfoil plants, leading to a reduction in plant growth (MacRae et al., 1990). In experimental feeding trials, the milfoil midge showed a strong preference for Eurasian watermilfoil, but when removed as a food choice, it also fed on the native *Myriophyllum sibiricum* and *Potamogeton* spp. Regular feeding and case-building was only observed on *Myriophyllum* species (MacRae et al., 1990).

Due to the high specificity for Eurasian watermilfoil and the overlapping geographic distribution, MacRae et al. (1990) suggest that the milfoil midge may have

been introduced to North America, whereas others propose that it is endemic to North America and evolved with a native host, *M. sibiricum* (Kangasniemi, Speier & Newroth, 1993; Newman & Maher 1995).

The rapid rate at which the milfoil midge larvae consume meristem tissue and the resulting control of Eurasian watermilfoil growth observed in experiments (Huber & Mason, 2002) have resulted in interest in the milfoil midge as a biological control agent. The challenge that has yet to be overcome is successful mass propagation of the milfoil midge in a laboratory setting. In a natural setting, males form vertical mating swarms high above the water, a situation that is difficult to recreate in the laboratory (Huber & Mason, 2002).

1.2.2.2 The water veneer moth, *Acentria ephemerella*

The water veneer moth was found to be associated with a number of natural milfoil declines in North America (Creed & Sheldon 1992, 1993, 1994; Johnson et al., 2000; Painter & McCabe, 1998). Much research was undertaken to determine the potential of this species as a biocontrol agent for controlling Eurasian watermilfoil growth, as it was suspected to be the agent responsible for the observed natural declines. Experiments conducted in aquaria support the hypothesis that the water veneer moth was capable of causing Eurasian watermilfoil declines observed in the Kawartha Lakes of Ontario and Cayuga Lake, New York (Painter & McCabe, 1998; Creed & Sheldon, 1994a; Gross et al., 2001).

The water veneer moth shows traits favourable for use as a biological control agent, including widespread occurrence in North America. Although not native to North America, the first naturalized population in Canada was discovered in 1927 near

Montreal, Quebec (Buckingham & Ross, 1981). From there, its range expanded into the Great Lakes system and south into the United States (Balciunas, 1982). Balciunas (1982) studied the insects associated with Eurasian watermilfoil in the United States and found that feeding by the water veneer moth caused the most damage to Eurasian watermilfoil. The phenology of the water veneer moth also parallels that of Eurasian watermilfoil; the peak plant biomass occurs in June and September in most locations and coincides with the active larval feeding period (Painter & McCabe, 1988; Batra, 1977).

Impacts to the Eurasian watermilfoil plant result from larvae feeding activity and shelter construction. Larvae build shelters from the growing tips of the plant, and this has been demonstrated to impede the plant's growing ability. Water veneer moth damage can be identified as abscission of the plant tissue at the apical meristem, stripped leaf material and girdled stem (Batra, 1977; Gross et al. 2001). A reduction in plant biomass and height results from an interruption of photosynthesis and damage to the growing tip of the plant (Batra, 1977; Gross et al., 2001).

Although there are many characteristics of the water veneer moth that makes it suitable for use as a biological control agent, perhaps the most significant factor limiting its usefulness is its feeding behaviour. The larvae are generalist herbivores (Buckingham & Ross, 1981) and lack host specificity for Eurasian watermilfoil. Because of the lack of host-specificity, there exists potential for introduced water veneer moths to negatively impact the native plant community. Although it has shown preference for Eurasian watermilfoil over most species of native aquatic macrophytes in the United States, an important exception is the native *Potamogeton* species which are also a preferred food source for the larvae (Johnson & Blossey, 2002).

The upper temperature threshold for larval development is another important factor that would limit the effectiveness of the water veneer moth to control Eurasian watermilfoil in certain lakes. At 22°C, the development of larval instars, the only stage in the lifecycle capable of impacting the plant, is disrupted. The larval stage lasts for over 10 months (Batra, 1977; Gross et al., 2001); therefore, the opportunity for full larval development in waterbodies such as Christina Lake where surface temperatures approach 30°C is unlikely. If the water veneer moth were used as a biological control agent for Eurasian watermilfoil, careful site selection would be required to ensure the temperature profile of the waterbody does not exceed the upper threshold for larval development (22°C). Furthermore, it has been observed that when larvae feed on Eurasian watermilfoil, stem girdling leads to fragmentation (Creed & Sheldon 1994), which can potentially aid the dispersal of plants into new areas.

1.2.2.3 The milfoil weevil, *Euhrychiopsis lecontei*

In some cases of natural Eurasian watermilfoil declines, the pattern of insect damage on the plants was not consistent with the feeding patterns of the water veneer moth or other known Eurasian watermilfoil herbivores. In Brownington Pond, Vermont, researchers investigating a milfoil bed collapse found holes bored in Eurasian watermilfoil stems by larvae of the milfoil weevil, *E. lecontei* (Creed et al., 1992; Creed & Sheldon, 1995). Other cases of natural Eurasian watermilfoil declines throughout the United States and Canada coincided with milfoil weevil presence (Creed & Sheldon, 1995; Lille & Helsel, 1997; Creed, 1998).

Adult milfoil weevils (Figure 5) are approximately 2 to 3 mm in length and can be characterized by a long snout and yellow and black stripes along the length of their body.

Most stages of the weevil's lifecycle occur underwater in close association with watermilfoil plants. Adults feed on milfoil plant tissue and utilize cover that the plants provide. Female weevils lay 1 to 2 eggs per day on the apical meristems of the milfoil plant, where they incubate for 3 to 6 days at water temperatures between 20 and 25°C (Cofrancesco & Crosson, 1999). Once the eggs hatch, larvae consume meristem tissue and feed their way into the milfoil stem. Larvae develop inside the milfoil stem, while feeding on vascular tissue of the plant. After 8 to 15 days (at 20 to 25°C), larvae create a puparium and undergo pupation inside the milfoil stem (Cofrancesco & Crosson, 1999). Adult weevils emerge after 9 to 12 days (at 20 to 25°C) and feed until they gain sufficient energy to reach sexual maturity, at which point, the lifecycle repeats (Mazzei et al. 1999). Weevil development success and development rate are dependent on temperature. The complete lifecycle can occur in as little as 17 days at 31°C, or as long as 62 days at 15°C (Mazzei et al. 1999). A drop in water temperature triggers adult weevils to divert energy away from the formation of gametes so that flight muscles can be developed. Milfoil weevils fly from milfoil beds to suitable terrestrial overwintering habitat, where they burrow into leaf litter and upper soil layers.



Figure 5. Adult milfoil weevil, *Euhrychiopsis lecontei* (Iowa State University, 2016)

The milfoil weevil is native to North America and has evolved with its historical host plant, *M. sibiricum*, Northern watermilfoil (O'Brien & Wibmer, 1982; Creed & Sheldon, 1994b). It is hypothesized that upon the introduction of Eurasian watermilfoil to North America, the feeding preference the milfoil weevil shifted from the native host plant to the introduced Eurasian watermilfoil (Solarz & Newman, 2001). Although the potential exists for the milfoil weevil to be present in all areas of Northern and Eurasian watermilfoil range, native populations of the milfoil weevil have been verified in five Canadian provinces (British Columbia, Alberta, Saskatchewan, Manitoba and Ontario), and 12 states (Creed, 1998; Jester, Bozek, Helsel & Sheldon, 2000) as shown in Figure 4.

Creed (1998) examined the biogeographical relationship between the native range of the milfoil weevil and locations of documented natural Eurasian watermilfoil declines. Creed found that the location of natural Eurasian watermilfoil declines followed a non-random pattern and overlapped the native range of the milfoil weevil, further supporting the hypothesis that the milfoil weevil is at least associated with the host plant, and may be

capable of causing Eurasian watermilfoil declines. Table 2 provides a comparison between the three potential biological control agents.

Table 2. Comparison of three invertebrate herbivores for the purpose of biological control of Eurasian watermilfoil

Invertebrate	<i>Cricotopus myriophylli</i>	<i>Acentria ephemerella</i>	<i>Euhrychiopsis lecontei</i>
Common name	Milfoil midge	Water veneer moth	Milfoil weevil
Range in North America	Widespread, from B.C. to New York.	Widespread	12 US states and 5 Canadian provinces.
Origin	Inconclusive; Europe/Asia or North America.	Europe	North America
Feeding behavior	Milfoil specialist	Generalist herbivore	Milfoil specialist
Positive attributes for biocontrol purposes	Larvae consume meristem tissue at a rapid rate. Milfoil specialist.	Larvae feeding and shelter building has been shown to significantly impact milfoil growth.	Larva burrowing activities causes loss of buoyancy in plants and interrupts nutrient flow. Milfoil specialist.
Challenges for biocontrol purposes	Reproduction dependant on forming a large mating swarm. Conditions have yet to be created in the laboratory that allow for successful propagation.	Generalist feeding behavior. Upper temperature threshold for development is lower than that of <i>E. lecontei</i> . Feeding behavior can aid dispersal of Eurasian watermilfoil.	Documented augmentation programs show variable results. In most cases, weevil populations require ongoing augmentation to effectively control Eurasian watermilfoil.
References	McRae et al., 1990; Johnson & Blossey; 2002; Newman, 2004	Creed & Sheldon, 1992, 1993, 1994; Johnson et al., 2000; Painter & McCabe, 1998	Creed et al., 1992; Creed & Sheldon, 1995; Lillie & Helsel, 1997; Creed, 1998

1.2.3 Laboratory experiments

Following the observations of the association of milfoil weevil and natural declines of Eurasian watermilfoil, researchers conducted laboratory experiments to further explore the potential of the milfoil weevil as a biological control agent for Eurasian watermilfoil (Creed & Sheldon, 1992, 1993, 1994; Creed et al., 1992 1998; Newman et al., 1996; Creed & Sheldon, 1993, 1995; Solarz & Newman, 1996). Research hypotheses were formulated regarding the effect the milfoil weevil had on the growth of Eurasian watermilfoil. Feeding behaviour, oviposition preference, life cycle and life history characteristics of the milfoil weevil were described.

In many cases of natural Eurasian watermilfoil declines, a common characteristic of the impacted milfoil beds was the loss of buoyancy of the plants. Laboratory studies confirmed the hypothesis that the loss of buoyancy could be caused by insect herbivory (Creed & Sheldon, 1992). Although the milfoil weevil was suspected to be responsible for loss of buoyancy, a study by Creed & Sheldon (1992) could not differentiate its effect from that of the water veneer moth, larvae of which were inadvertently included in milfoil weevil-only treatments. A subsequent study by Creed & Sheldon (1994) examined the effects of the water veneer moth alone, milfoil weevil alone, and both together on Eurasian watermilfoil growth. It was found that each insect had the capability to significantly reduce Eurasian watermilfoil growth. During this study, milfoil weevil larvae were observed to feed by burrowing longitudinally through the stem, up to 8 mm per day.

The negative effects of larvae burrowing through the stems of Eurasian watermilfoil plants can surpass the damage caused by herbivore grazing alone (Creed & Sheldon, 1993). Bore holes in the stem compromise the integrity and damage the lacunae,

which results in a release of gases that normally help the plant float (Creed et al., 1992; Grace & Wetzel, 1978). The resulting loss of buoyancy has impacts on the plant's ability to perform photosynthesis if drawn down to lower light conditions. A reduced capacity to perform photosynthesis results in insufficient energy available for growth and maintenance of the plant (Creed et al., 1998) and carbohydrate storage (Newman et al., 1996). In dense stands of Eurasian watermilfoil, where buoyancy is affected in some but not all plants, the sinking action of milfoil weevil-affected plants can draw down adjacent plants as well, increasing the impact to the stand (Creed et al., 1992). Damage to the stem can also interrupt the flow of energy and oxygen between the upper and lower portions of the plant, and nutrient movement from the roots to other areas of the plant (Carigan & Kalff, 1980).

Part of Creed and Sheldon's research in Brownington Pond involved feeding experiments in outdoor pools to assess the potential for Eurasian watermilfoil herbivores to decrease the plant's biomass and stem length. Results of these experiments showed that milfoil weevils can suppress the production of new watermilfoil biomass and root production (Creed & Sheldon, 1995). Decreases in biomass result not from consumption of existing plant tissue, but from the interruption of new growth by larvae (Newman et al., 1996).

When stem fragmentation results from milfoil weevil feeding activities, the resulting stem fragments are less viable and are less likely to lead to colonization of new areas (Creed & Sheldon, 1995). In contrast, water veneer moth feeding behavior can lead to an increase in stem fragmentation and stem segments retain their viability (Creed & Sheldon, 1994a).

The milfoil weevil is a *Myriophyllum* specialist, showing oviposition preference on *Myriophyllum* species over other native plants and feeds exclusively on *Myriophyllum* species (Solarz & Newman, 1996; Creed & Sheldon, 1995; Sheldon & Creed, 1995). When no-choice experiments were conducted by Solarz and Newman (1996) out of 207 female weevils that laid eggs, only three oviposited on non-*Myriophyllum* plants, and feeding did not occur.

When comparing feeding and oviposition preference of the milfoil weevil within the native and non-native milfoils, the milfoil weevil prefers the non-native Eurasian watermilfoil over others (Solarz & Newman, 1996; Sheldon & Creed, 2003; Newman et al., 1997). The milfoil weevil will feed on watermilfoils native to North America and oviposit on select native milfoil species, but when compared to Eurasian watermilfoil, fewer eggs are laid on native milfoils, and lower number of larvae result (Sheldon & Creed, 2003). In experiments, the development performance of the milfoil weevil was found to be higher in those with a diet of Eurasian watermilfoil than those fed the native Northern watermilfoil (Solarz & Newman, 1996; Newman et al., 1997; Solarz & Newman, 2001).

Laboratory experiments demonstrated that feeding activities of the milfoil weevil had a negative effect on three native milfoil species, *Myriophyllum verticillatum*, *Myriophyllum alterniflorum* and *Myriophyllum humile* (Sheldon & Creed, 2003). During these experiments, larvae were introduced at high densities, higher than typical rates required for Eurasian watermilfoil control (Sheldon & Creed, 2003). It was suggested by Creed and Sheldon (2003) that by stocking at rates more typical of those required for Eurasian watermilfoil control, impacts on native milfoils would be negligible. As feeding by the milfoil weevil can have negative effect on native milfoil species, in locations of

Georgia and North Carolina where the Threatened Species *Myriophyllum laxum* exists (USDA, 2015b; Chafin, 2010; NCAC, 2010), biological control measures using the milfoil weevil should be avoided.

Extensive laboratory studies have been conducted to describe the life history and development performance of the milfoil weevil (Solarz & Newman, 1996; Sheldon & O'Bryan, 1996; Mazzei, Newman, Loos & Ragsdale, 1999; Roley & Newman, 2006; Tamayo & Grue, 2004). The milfoil weevil is capable of rapid development from egg to adult, which allows for substantial population growth in a season. The complete lifecycle can occur in 17 days at optimum temperatures (Mazzei et al., 1999), permitting multiple generations in a single season. The optimum temperature range for complete development is between 25 and 29 °C (Mazzei et al., 1999), which is well suited to the temperature regime of the littoral zone in Eurasian watermilfoil beds (Unmuth et al., 2000).

Results of laboratory and field experiments described in this section were consistent with the hypothesis that the milfoil weevil is capable of causing the type of Eurasian watermilfoil declines observed in Canada and the United States. Characteristics that make the milfoil weevil desirable for use as a biological control agent include its selective feeding behaviour, the level of Eurasian watermilfoil control achieved, its widespread distribution across North America, the belief that it is native to North America, and its preference to feed and oviposit on the invasive Eurasian watermilfoil.

1.2.4 Experimental milfoil weevil releases

Field experiments designed to quantify the effect of the milfoil weevil on Eurasian watermilfoil biomass and abundance in the natural environment were conducted. These

studies were designed as either enclosure experiments or unrestricted releases in waterbodies throughout the eastern United States and Canada (Parsons, Marx & Divens, 2011; Hanson, Eliopoulos & Walker, 1995).

Creed and Sheldon (1995) conducted experiments in Brownington Pond and Norton Brook Reservoir, Vermont to quantify the effect of the milfoil weevil on Eurasian watermilfoil. They used enclosures to contain introduced weevils and then monitored change in milfoil biomass and plant height. Results showed a significant reduction in lateral stem and root biomass, and plant height in the enclosures, suggesting that weevil herbivory could reduce milfoil biomass in the field. Middlebury College was involved in experimental milfoil weevil introductions in Lake Bomoseen, Vermont, where two years of augmentation was followed by four years of monitoring. Quantitative analysis suggests that a milfoil weevil population established in the Lake and milfoil biomass decreased after the augmentation events (USEPA, 1997).

Middlebury College also reared milfoil weevils for field experiments conducted by the Massachusetts Department of Environmental Management in Mansfield Lake (City of Pittsfield, 2009). Approximately 12,000 milfoil weevils were added to the Lake each year for three years between 1995 and 2001. Studies following augmentation events showed damage to Eurasian watermilfoil indicative of milfoil weevil activity and an observed shift away from Eurasian watermilfoil-dominant plant communities. In 2012, Eurasian watermilfoil still made up a component of the aquatic plant community, but in small quantities and plants were in poor condition (Geosyntec Consultants, 2012).

In Wisconsin, 12 lakes were augmented with the milfoil weevil to determine the effectiveness of augmentation at different rates (Jester et al., 2000). Significant declines in Eurasian watermilfoil biomass and stem density were observed in 100% of the lakes

receiving the highest augmentation rate of four milfoil weevils per stem. Of the sites treated with the lowest augmentation rate of one milfoil weevil per stem, 60% experienced a significant decline in Eurasian watermilfoil biomass and stem density (Jester et al., 2000).

Parsons et al. (2011) conducted a seven-year study during which they performed experimental introductions of the milfoil weevil in 2002 and 2003 in Mattoon Lake, Washington. Monitoring of macrophytes, macroinvertebrates and fish communities continued for an additional five years post-augmentation. Over the course of the monitoring, they identified a trend of decreasing Eurasian watermilfoil biomass, although concluded that a number of herbivores were likely responsible for the decline, including the milfoil weevil, the milfoil midge, and the tardy caddisfly (*Triaenodes tardus*). After the milfoil weevil introductions, it took a number of years for the milfoil weevil population to establish in the lake, with significant numbers observed only during the last few years of the study. Competition between herbivores may have played a role in the delayed milfoil weevil establishment (Parsons et al., 2011).

1.3 Commercial milfoil weevil augmentation programs

With the advances in weevil rearing methods and the commercial availability of weevils, lake management organizations and private groups implemented weevil augmentation programs in an effort to control Eurasian watermilfoil in lakes throughout the United States and Canada. Augmentation implies that a native milfoil weevil population exists in the waterbody prior to the addition of laboratory-reared milfoil weevils.

1.3.1 Augmentation programs in the United States

Commercial augmentation programs appeared in the United States in the late 1990's and were primarily carried out by the company EnviroScience Inc. (Stow, Ohio) as part of their Middfoil™ Process, a patented process of culturing weevils in the laboratory, developed by Sallie Sheldon, a professor at Middlebury College in Vermont (Zawacki, 2002). By 2006, over 85 lakes had been augmented with milfoil weevils by EnviroScience Inc. (Hilovsky, 2006) and by 2014 it is estimated that well over 100 lakes across North America have been augmented with commercial weevils.

In 1998, Lake St. Helen, Michigan was the first that was stocked with commercially produced milfoil weevils. Over the course of five years, sites in the shallow lake received approximately 78,000 weevils. EnviroScience Inc. performed follow up monitoring of Eurasian watermilfoil and milfoil weevil density annually, and reported successful control of Eurasian watermilfoil at all sites monitored in Lake St. Helen (EnviroScience Inc., no date).

With the success of Lake St. Helen, other lake management groups battling Eurasian watermilfoil retained EnviroScience Inc. to provide the Middfoil™ service. Milfoil weevil augmentation programs spread across the United States to areas of Michigan, Wisconsin, Indiana, Connecticut, New York, Colorado, Massachusetts, Illinois, Arkansas and Washington.

As part of EnviroScience Inc.'s milfoil weevil augmentation protocol, standard methodology was followed for pre-augmentation assessments and follow up monitoring. At each established study site, at a minimum, the density of Eurasian watermilfoil plants and the milfoil weevil population were assessed. Surveys were typically done before milfoil weevils were released, approximately five to eight weeks after weevil release and

in some cases annually for one to two years (EnviroScience Inc., 2012; Milfoil Solution Inc. 2012).

EnviroScience Inc.'s data from weevil augmentation programs in 29 lakes in Michigan and Wisconsin were analyzed by Reeves, Lorch, Kershner & Hilovsky (2008) to determine the efficacy of the milfoil weevil in controlling Eurasian watermilfoil growth. Results of the study indicate that substantial variation exists in the effectiveness of the milfoil weevil at controlling Eurasian watermilfoil in natural lake environments, suggesting that other factors besides milfoil weevil density play a role in Eurasian watermilfoil abundance. Lake characteristics including depth and area were not found to be associated with milfoil weevil or Eurasian watermilfoil density changes.

A study examining the impact of milfoil weevil releases on Eurasian watermilfoil populations in Round, Griffy and Little Turkey Lake, Indiana was performed by Scribailo and Alix (2003). EnviroScience Inc. augmented these lakes with milfoil weevils in 2000 and 2001. The results of the independent assessment were inconclusive; milfoil weevil augmentation could not be attributed to a decrease in Eurasian watermilfoil density. The authors suggest that fluctuations observed in the milfoil densities over time were more likely a result of fluctuating environmental conditions observed over the course of the study (Scribailo & Alix, 2003; Burlingame, 2004).

1.3.2 Augmentation programs in Canada

The first documented augmentation of the milfoil weevil in Canada occurred in Lac Supérieur, Quebec, where 30,000 weevils were released from 2005 to 2007 (Lavoie, 2010). EnviroScience Inc., in partnership with the Canadian company Biofilia,

coordinated the permitting, importation and release of the milfoil weevils (Hilovsky, 2006).

EnviroScience Inc. was retained by a number of private organizations and stewardship groups to provide milfoil weevils for augmentation programs throughout Ontario. Figure 6 shows the locations of documented commercial weevil augmentation programs in Canada to date. These biological control programs are located in Ontario, with the exception of the first augmentation site in Quebec.

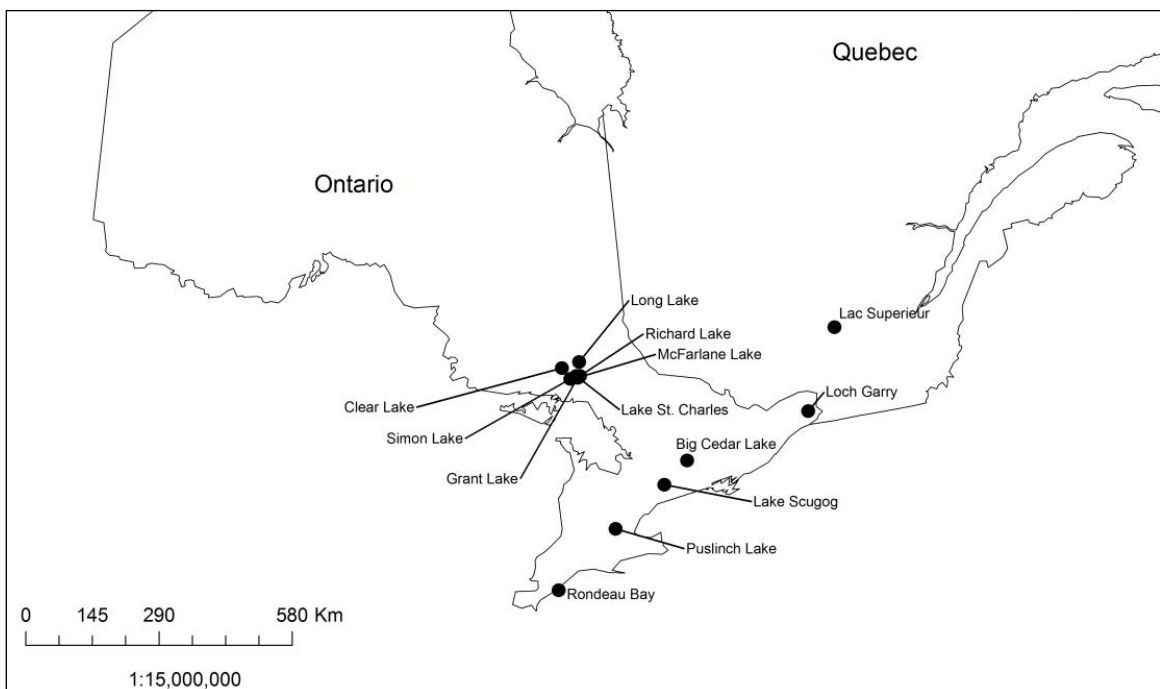

Figure 6. Locations of commercial biological control programs in Canada, using the milfoil weevil as a control agent for Eurasian watermilfoil (EnviroScience Inc., 2011, 2012, 2013a, 2013b, 2014)

In 2006, the Lake Owners Association of Puslinch Lake, Ontario coordinated a biological control program to address the Eurasian watermilfoil infestation. A drastic reduction in Eurasian watermilfoil density was observed in the years following the augmentation with milfoil weevils (May 2010), although more recent reports indicate recovery of Eurasian watermilfoil to pre-treatment levels (Waterloo Region Record,

2011). After the reported initial success of the milfoil weevil augmentation program, at least 11 other lakes in Ontario were subject to milfoil weevil augmentations as part of Eurasian watermilfoil management programs.

Between 2008 and 2010, 36,000 weevils were placed in Clear Lake Ontario. Results of monitoring conducted by EnviroScience Inc. described a decrease in Eurasian watermilfoil density by 70% and 80% in the two sites stocked with milfoil weevils and an increase of native macrophyte species from 5 to 12. The final sampling event (post-augmentation) was conducted by EnviroScience Inc. on September 2, 2010 (Cushing, no date). Assessing Eurasian watermilfoil late in the season, after the onset of natural senescence which typically occurs in late August, could potentially attribute seasonal declines to that caused by weevils (Reeves et al., 2008).

Scugog Lake is an ecologically diverse, shallow lake in Southern Ontario that forms part of the Trent-Severn Waterway (Scugog Lake Stewards, 2012, 2015). In 2006 the presence of Eurasian watermilfoil x *M. sibiricum* hybrid was confirmed in the lake and has since been found throughout the Kawartha Lakes and Trent-Severn system (from the Bay of Quinte to Georgian Bay, Ontario) (Borrowman,, 2012). Hybrid milfoil poses an additional challenge for control, as it displays vegetative vigour responsible for more aggressive growth than Eurasian watermilfoil or *M. sibiricum* (Moody & Les, 2002). As part of a pilot project initiated in 2009 to determine the effect of the milfoil weevil on the watermilfoil population in Scugog Lake, the Scugog Lake Stewards in conjunction with Trent University and EnviroScience Inc. released 20,000 weevils in the northern portion of the lake. Results of annual monitoring over the next three years by EnviroScience Inc. and Trent University biologists have shown the pilot project to be successful and in 2014

a second batch of 10,000 weevils were released at an alternate site in the lake (Scugog Lake Stewards, 2012, 2014).

Loch Garry, Ontario is also a large shallow lake that had a heavy infestation of Eurasian watermilfoil. The Loch Garry Lake Association coordinated a milfoil weevil augmentation program to address Eurasian watermilfoil growth and 40,000 weevils were released in 2012 (Milfoil Solution Inc., 2012). During follow-up monitoring, a reduction in Eurasian watermilfoil density was observed in three of the four release sites, while the control site showed an almost 100% increase in density (Milfoil Solution, 2012). An additional 50,000 milfoil weevils were released in 2013 (Loch Garry Lake Association, 2013). Monitoring results in 2013 showed a reduction in Eurasian watermilfoil density from 2012 in all augmented sites (EnviroScience Inc., 2013a).

Between 2011 and 2013, six lakes surrounding the city of Sudbury, Ontario were augmented with milfoil weevils in an effort to control Eurasian watermilfoil infestations. EnviroScience Inc. was involved with the program, as was the City of Greater Sudbury, College Boreal and the Greater Sudbury Watershed Alliance. In Long Lake alone, almost 95,000 weevils were released over three years, with a project cost of \$170,000. It was thought that the unusually warm summer of 2012 promoted milfoil growth, thereby decreasing the relative degree of damage and resulting effectiveness of weevil control (EnviroScience Inc., 2013b; Greater Sudbury, 2014; Greater Sudbury Watershed Alliance, 2014).

In southern Ontario, Eurasian watermilfoil infested areas of Rondeau Bay were augmented by EnviroScience Inc. Data are not readily available, but reports of weevil augmentations occurring in 2010 (May, 2010) and 2013 (EnviroScience Inc., 2013a)

summarize the results. Follow up monitoring by EnviroScience Inc. indicated an increase in milfoil density at one of the augmentation sites by 111% (EnviroScience Inc., 2013a).

1.3.2.1 Augmentation program outcome in Ontario lakes

Eight lakes from Ontario subject to milfoil weevil stocking by EnviroScience Ltd. were chosen for a more in-depth review. The review was based on publicly available datasets containing pre-stocking and post-stocking milfoil density (plants m^{-2}) in addition to the number of milfoil weevils released at each stocking site (EnviroScience Inc., 2011, 2012, 2013a, 2013b, 2014). At each augmentation and control site, EnviroScience Inc. followed a standard methodology to assess and record the average Eurasian watermilfoil density (plants m^{-2}) in 30 quadrats placed randomly along transects established at each site. Each year that a site was included in the weevil augmentation program, the relative change in milfoil density before and after treatment with milfoil weevils was calculated (Table 3 and Figure 7). This was done by subtracting the post-treatment milfoil density value from the initial value then dividing by the initial milfoil density value. Sites with relative change in plant density values less than zero experienced a decrease in Eurasian watermilfoil density from initial pre-treatment conditions and were classified as “success”. Sites with a positive change in plant density values post-treatment were classified as “failure,” as milfoil density increased from the pre-treatment assessed values.

Table 3. Relative change in Eurasian watermilfoil density after treatment with milfoil weevils in eight Ontario lakes, 2011 to 2014. Adapted from EnviroScience Inc. 2011, 2012, 2013, 2014.

Lake, Site		Weevils released ¹				Relative change in milfoil density (plants m ⁻²)			
		2011	2012	2013	2014	2011	2012	2013	2014
Grant	S1	0	5000	4000	0	-	1.66	-0.381	-
Long	S1	5750	5500	0	0	-0.817	-0.17	-	-
Long	S2	5750	0	0	0	1.40	-	-	-
Long	S3	5750	5500	5000	0	0.053	0.96	0.029	-
Long	S4	5750	0	0	0	0.245	-	-	-
Long	S5	0	0	5000	0	-	-	0.125	-
McFarlane	S1	5000	0	0	0	0.095	-	-	-
McFarlane	S2	5000	0	6000	0	0.833	-	-0.279	-
McFarlane	S3	5000	5000	0	0	0.552	-0.14	-	-
Richard	S1	9000	3500	0	0	0.071	0.79	-	-
Richard	S2	9000	3500	6000	0	0.687	0.84	-0.448	-
Simon	S1	10000	10000	0.00	0	-0.778	3.61	-0.462	-
St. Charles	S1	9700	7000	4000	0	-0.748	-0.07	-0.544	-
Big Cedar	S1	6000	5833	5416	4666	0.822	-0.18	-0.068	-0.171
Big Cedar	S2	6000	5833	5416	4666	1.37	0.74	-0.667	-0.484
Big Cedar	S3	6000	5833	5416	4666	-0.530	2.14	-0.108	-0.119
Big Cedar	S4	6000	5833	5416	4666	0.411	2.69	-0.024	-0.288
Big Cedar	S5	6000	5833	5416	4666	0.472	0.84	-0.027	-0.191
Big Cedar	S6	-	5833	5416	4666	-	1.73	0.364	-0.381
Big Cedar	M1	0	-	-	-	-0.659	-	-	-
Big Cedar	M2	0	0	0	0	0.031	2.17	-	1.75
Garry	S1	0	0	0	0	-	-0.31	-0.691	-
Garry	S2	0	0	0	0	-	-0.31	-	-
Garry	S3	0	0	0	0	-	-0.02	-0.265	-
Garry	S4	0	0	0	0	-	0.97	-0.833	-
Garry	S5	0	0	0	0	-	-	-0.288	-
Garry	M1	0	0	0	0	-	1.11	-0.346	-

¹ When not specified, the number of weevils released at each site was determined by dividing the total number of weevils released by the number of sites in the lake. Equal distribution among sites was assumed.

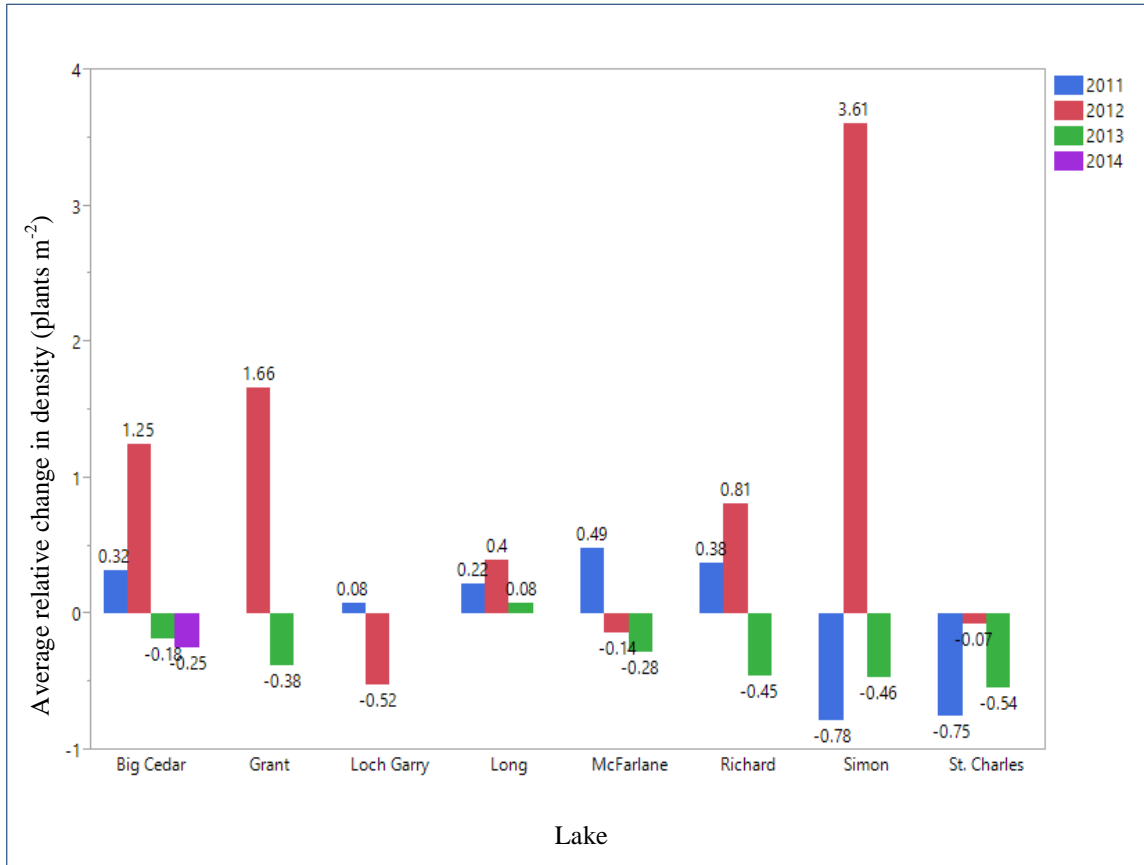

Figure 7. Relative change in Eurasian watermilfoil density after milfoil weevil augmentation in eight Ontario lakes between the period of 2011 and 2014 (adapted from EnviroScience Inc.)

An odds ratio was used to compare treatment sites augmented with weevils to control sites receiving no weevil augmentation. This statistic describes the odds that an outcome (success or failure) will occur given a particular exposure (weevil treatment or control). Sample plots in which milfoil density (plants m^{-2}) post-treatment was less than milfoil density pre-treatment (relative density value < 0) were described as success. Plots where milfoil density was greater post-treatment (relative density value > 0) were described as failure.

The odds ratio was calculated using the following equation:

$$\text{Odds ratio} = \frac{a \times d}{b \times c} \quad (1)$$

Where a, b, c and d are defined in Table 4, below.

Table 4. Frequency of success and failure for weevil treatment and control groups

Group	Success	Failure
Treatment	a (31)	b (26)
Control	c (2)	d (4)

The resulting odds ratio value of 2.38 indicates that the plots receiving treatment (weevil augmentation) were 2.38 times more likely to see success of reduced milfoil density than the control group receiving no weevils. Significance was tested using the 2-tail Fisher’s Exact test as it does not depend on large-sample distribution assumptions and is appropriate for smaller sample sizes. The probability that outcome is independent of treatment group is 0.412, greater than the significance level of 0.05; therefore we cannot reject the null hypothesis that treatment with weevils does not affect the outcome.

The weevil augmentation programs designed to reduce Eurasian watermilfoil abundance in lakes across the United States and Canada have experienced variable results. In some instances, effective control has been realized after just one year of augmentation and has remained effective for up to a decade. In other cases, weevil augmentations were followed by years of increased Eurasian watermilfoil density.

Since the 1980’s, the milfoil weevil has been the focus of research for potential use as a biological control agent for Eurasian watermilfoil. Early reports of the milfoil weevil presence associated with Eurasian watermilfoil declines that could not be attributed to management activities stimulated decades of research with the aim of using

the milfoil weevil to manage economically and ecologically costly Eurasian watermilfoil infestations. As the milfoil weevil became commercially available, lake managers across North America carried out augmentation programs, with varying success. In few cases, complete Eurasian watermilfoil control was observed, whereas in other lakes, no change was observed or short term success was achieved. More research is needed to gain knowledge of when and where weevils will be effective at controlling Eurasian watermilfoil.

Miller et al. (2011) identified that ecological models could provide lake managers with insight to the effectiveness of biological control programs prior to expending significant resources.

CHAPTER 2—SIMULATION MODEL

Simulation models can be useful tools when used by decision makers assessing options for invasive plant control options. Biological control is just one of the options available for control of invasive species, and in some cases it may not be the best option. In the previous chapter, case studies of biological control programs using the milfoil weevil were examined and it was found that project success varied between location and year. The benefit of using a simulation model is that the projected results can be viewed before a system is modified, early in the planning stages of a weevil augmentation program. To help understand the prolific growth of these invasive species, researchers have developed different aquatic plant productivity models (Best & Boyd, 1999, 2001; Herb & Stefan, 2006; Titus et al., 1975; Miller, Roketenetz & Garris, 2011).

Building upon previous models, a simulation model was developed for Christina Lake to gain a more thorough understanding of the potential interaction between the invasive Eurasian watermilfoil and the milfoil weevil should an augmentation program occur. This chapter focuses on the model development process, the parameters and variables used in the model and results of different weevil augmentation scenarios.

The simulation model was designed to provide estimates of Eurasian watermilfoil biomass (grams DW m⁻²) over the course of the 189-day growing season in Christina Lake. Spatially, milfoil biomass was mapped over a base area of one square metre. The main drivers of the model are surface water temperature and solar radiation, for which local datasets were used. Milfoil growth and weevil development parameters were obtained from the literature and in some cases were modified to provide more accurate representation of the conditions of Christina Lake.

Two sub-models make up the simulation model; one mapping Eurasian watermilfoil (hereafter referred to as “milfoil”) biomass accumulation and the second modeling the milfoil weevil population. The larva stage from the weevil population model provided the interface for integrating the weevil-watermilfoil model. Larva of the milfoil weevil interrupts the storage of non-structural carbohydrates and impacts the plant biomass directly by burrowing and feeding activities (Miller et al., 2011). The other interaction occurs at the weevil egg laying stage, as the number of available milfoil meristems can be a limiting resource for egg laying, thereby limiting weevil population growth.

To simulate a biological control program where weevils were introduced into the lake, the model was run with different augmentation rates (weevils m^{-2}) to determine the response of the milfoil biomass over the course of a season.

2.1 Conceptual model

The simulation model described in this chapter was based on a previously developed model by Miller et al. (2011), where a milfoil productivity model was incorporated with an age-structured weevil population model. For the milfoil productivity sub-model, Miller et al. (2011) built upon work done by Herb and Stefan (2003, 2006) and drew components from the WEED model (Titus et al., 1975). Both Herb and Stefan (2003, 2006)’s and the WEED (Titus et al., 1975) model seek to fit aquatic plant biomass over time by using water depth, water clarity, water temperature and irradiance as model inputs. Miller et al. (2011) chose to incorporate an autofragmentation factor in their model which was originally defined in the WEED model (Titus et al., 1975). By including autofragmentation and a non-structural carbohydrate component in the model,

the typical double-peak of biomass observed over a growing season is more accurately represented (Miller et al., 2011).

Water temperature and irradiance are the main drivers of the model; they both strongly influence the growth potential of Eurasian watermilfoil, and the development rate of the milfoil weevil is temperature dependent (Smith & Barko, 1990; Mazzei et al., 1999; Newman et al., 2006, 2007; Confrancesco & Crosson, 1999; Herb & Stefan, 2003). Drivers related to Eurasian watermilfoil physiology such as photosynthesis, respiration and non-structural carbohydrates were included, as were plant height and autofragmentation. Figure 8 shows the relationship between the components of the model. Although nutrients and carbon source are shown in Figure 8, it was assumed that the availability was unlimited; therefore, these components are not considered main drivers in the milfoil growth model. Details of each model component are discussed later in this Chapter.

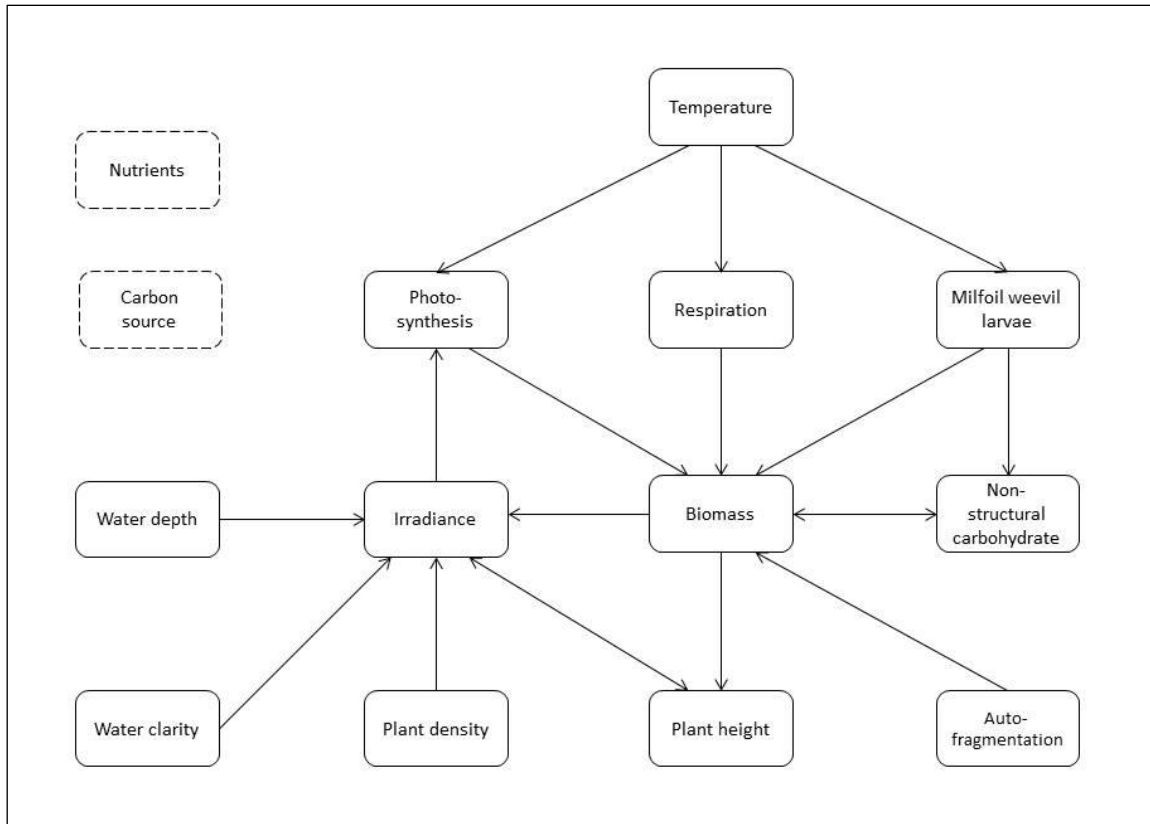

Figure 8. Conceptual model showing the main drivers that influence biomass accumulation of Eurasian watermilfoil as it relates to a weevil augmentation

2.1.1 Temperature

Temperature influences the rate of photosynthesis and respiration in plants (Stanley & Naylor, 1972; Pedersen, Colmer & Sand-Jensen, 2013), the timing of Eurasian watermilfoil spring growth (Smith & Barko, 1990) and the development rate of the milfoil weevil (Mazzei et al., 1999; Newman et al., 2006).

The energy and carbon needed to maintain and produce plant biomass is made available through the photosynthetic process. In conditions of unlimited irradiance and carbon availability, photosynthetic rates increase with temperature to the optimal temperature response point described by Taiz and Zeiger (2002) as the “point at which capacities of the steps involved in photosynthesis are balanced”. For Eurasian

watermilfoil the optimal temperature response point is between 30 and 35° C (Pedersen et al., 2013; Stanley & Naylor, 1972).

Respiration releases stored energy by metabolizing carbon compounds created as a result of photosynthesis. The rate of respiration is a function of temperature. Respiration rates rise quickly and at high temperatures, respiration occurs at a higher rate (Taiz & Zeiger, 2002). This reduces the carbon and energy available for accumulation of organic matter and growth of the plant. For this reason, the most efficient biomass accumulation occurs at temperatures lower than the photosynthetic optimum (Van et al., 1976; Pedersen et al., 2013; Grace & Wetzel, 1978). Respiration occurs continually, irrespective of light conditions, to provide energy needed for cell function. In Eurasian watermilfoil, photorespiration occurs simultaneously with photosynthesis and in the absence of light, “dark” respiration occurs (Grace & Wetzel, 1978).

In late summer, a majority of the Eurasian watermilfoil stems naturally senesce and fall to the substrate. Stems that remain viable can persist over the winter along with new shoots initiated in the fall (Smith & Barko, 1990). These shoots remain dormant until spring water temperatures reach approximately 15° C, at which point they begin rapid elongation which persists into the summer months (Smith & Barko, 1990).

After the overwintering period, female milfoil weevils begin to lay eggs on milfoil plants when the water temperature reaches 10 to 15° C (Newman et al., 2001).

Temperature governs milfoil weevil population dynamics, as the development rate of each lifecycle stage is dependent on the temperature of its environment (Mazzei et al., 1999). Mazzei et al. (1999) quantified the degree-day requirements for each stage of the lifecycle and determined the upper and lower temperature thresholds for the development of each life stage.

2.1.2 Irradiance

Irradiance, the power received from the sun, is the other main driving factor of the model and is responsible for biomass formation. Irradiance levels in the water decrease exponentially with depth, as a function of the absorption and light-scattering properties of water (Kirk, 2003). We can expect different irradiance values at the leaves of milfoil growing at different depths and also for plants at differing heights. The model attempts to describe these variations by factoring in site conditions for depth and milfoil height. Plant density and biomass affect the irradiance at depth due to physically blocking the passage of light, making it unavailable for plants below. A description of the irradiance dataset used in the model is found in Section 2.3.2.

2.1.3 Carbon source and nutrients

Inorganic carbon in the form of carbon dioxide (CO_2) and to a lesser extent bicarbonate ions (HCO_3^-), are taken up from the water for use in the photosynthetic process (Grace & Wetzel, 1978). In the pH range of 7 to 10, the most common form of inorganic carbon in freshwater systems is the bicarbonate ion (Pedersen et al., 2013). Readings from Christina Lake during the study averaged a pH of 7.8. Even though Eurasian watermilfoil shows a preference for the CO_2 form of inorganic carbon, the demands for inorganic carbon can be met, as the plant can convert bicarbonate ions to CO_2 (Grace & Wetzel, 1978; Titus, 1977; Swain, 1987).

Phosphorus and nitrogen levels obtained from water column sampling in Christina Lake are available (McGregor, 2007), but mineral nutrients are primarily taken up from sediment through the roots of Eurasian watermilfoil (Smith & Barko, 1990). A review of the historical studies conducted on Christina Lake did not identify any historical sediment

sampling events in the Lake. Future sampling and analysis for inorganic carbon and nutrient levels would enable the identification of components that may be limiting milfoil growth in Christina Lake and provide a better understanding of the relationship between the biotic and abiotic components of the ecosystem.

Although nutrient and inorganic carbon availability affect productivity in plants (Grace & Wetzel, 1978), data were not available for Christina Lake. Available nutrients and carbon were not explicitly modeled, but by manipulating the base growth rate for milfoil, reduced availability may be represented, as described later in this chapter.

2.1.4 Non-structural carbohydrates

In the overwintering period, Eurasian watermilfoil stores up to 20% of its total biomass as non-structural carbohydrates in overwintering stems and roots (Smith & Barko, 1990). This energy pool is utilized early in the growing season, before the temperature and light conditions permit the photosynthesis reactions to occur (Smith & Barko, 1990; Grace & Wetzel, 1978). Non-structural carbohydrate resources are directed toward rapid stem elongation, allowing a competitive advantage over native plants as light resources can become limited to plants below (Smith & Barko, 1990).

2.1.5 Autofragmentation

The primary method of reproduction and colony formation in Eurasian watermilfoil is through fragmentation of the stem (Aiken et al., 1979). Milfoil plants undergo one and in some areas two periods of “autofragmentation,” where the plant sheds the upper portions of the stem. Prior to separation, rooting structures are formed at the internodes near the top of the plant. The period of autofragmentation coincides with a

decrease in plant biomass as stem segments are separated from the parent plant (Madsen & Smith, 1997).

2.1.6 Milfoil weevil larva

The lifecycle, development time and survival rates of the milfoil weevil have been characterized (Mazzei et al., 1999; Newman et al., 1997; Sheldon & O'Bryan, 1996). This information was used to construct a population model with discrete development classes, following the method outlined by Miller et al. (2011).

The larva stage of the milfoil weevil lifecycle can inflict damage to the Eurasian watermilfoil plant sufficient to result in observed biomass decreases (Creed, 2000). Weevil adult and pupa stages can also impact the milfoil plant to a lesser degree; constructing the pupal chamber disrupts vascular tissue and feeding adults remove leaf material (Creed, 2000). As the damage inflicted by the adult and pupae life stages is minimal compared to that caused by the larvae, impacts to Eurasian watermilfoil resulting from these life stage were not included in the model.

Non-structural carbohydrate storage is interrupted by milfoil weevil larva during feeding and burrowing activities. Damage caused to the vascular tissue of the stem reduces the flow of carbohydrates between the upper portion of the plant where photosynthesis takes place and the roots, where carbohydrate storage occurs (Creed, 2000).

Weevil larvae also have significant impact on the buoyancy on Eurasian watermilfoil stems as their burrowing action is known to breach the chambers of the lacunae, thereby allowing gas to escape. The loss of buoyancy results in stems sinking to the substrate, into lower light conditions (Creed et al., 1992; Creed & Sheldon, 1995).

2.2 Model development

The purpose of the simulation model was to map the change in Eurasian watermilfoil biomass in the water column over a 1 m² base over the course of a growing season. Figure 9, below outlines the main factors governing biomass accumulation and loss. Biomass accumulation is a function of light resources available to the plant, water temperature and the available pool of non-structural carbohydrates. Biomass loss terms include losses due to respiration, autofragmentation, and damage inflicted by the milfoil weevil.

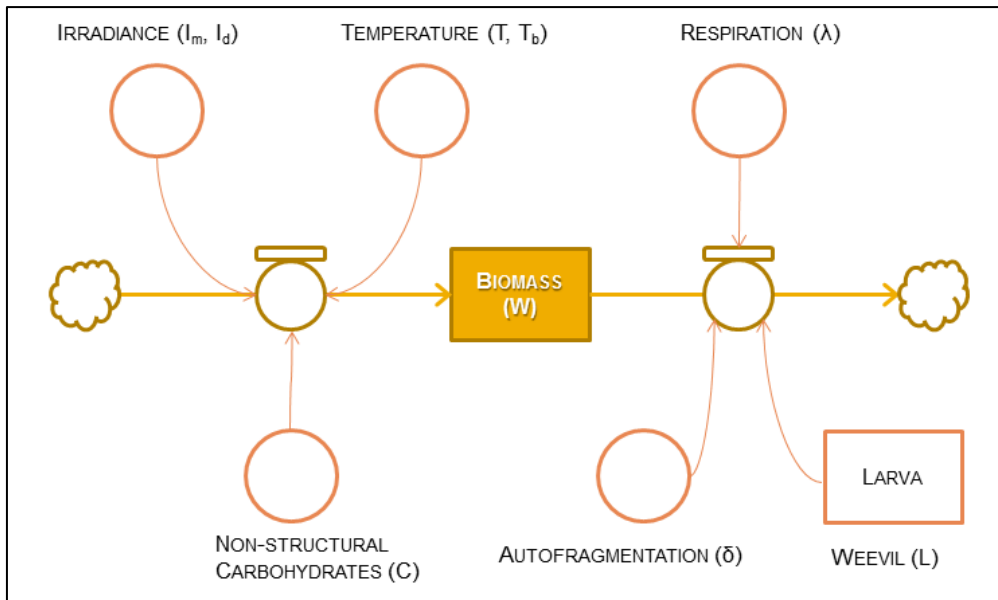

Figure 9. Eurasian watermilfoil biomass model structure

The following equation represents the accumulation of milfoil biomass (Miller et al., 2011; Herb & Stefan, 2003, 2006):

$$\frac{dW}{dt} = \frac{\mu_0 \theta_g^{T-T_b}}{k_m} \frac{k_m W}{K_{wt}h + k_m W} \ln \left(\frac{k_1 + I_m}{k_1 + I_d} \right) - (\lambda + \delta)W + \mu_1(1 - \mu_{tb})C - \gamma_2 L \quad (2)$$

Where,

W = Eurasian watermilfoil biomass (g DW m⁻²)

T = surface water temperature (°C)

C = non-structural carbohydrate reserves (g DW m⁻²)

L = larva population (number of individuals)

λ = losses due to respiration (g DW m⁻²)

δ = losses due to autofragmentation (g DW m⁻²)

I_m = light availability at top of milfoil stand (μEm⁻²s⁻¹)

I_d = light availability at bottom of milfoil stand (μEm⁻²s⁻¹)

Components of Equation 2 will be discussed in detail, following. The description of all parameters and values used in the model can be found in Table 9.

2.2.1 Eurasian watermilfoil biomass accumulation during periods of active photosynthesis

Milfoil biomass accumulation (W) during periods of active photosynthesis is modeled as a function of irradiance (I) and temperature (T), with variable inputs from the local datasets described in Chapter 3. Biomass accumulation is calculated in the first term of Equation 2:

$$\frac{\mu_0 \theta_g^{T-T_b}}{k_m} \frac{k_m W}{K_{wt}h + k_m W} \ln \left(\frac{k_1 + I_m}{k_1 + I_d} \right)$$

The base temperature for Eurasian watermilfoil growth (T_b) is defined as 10° C (Herb and Stefan, 2006), below this temperature, biomass accumulation from photosynthesis does not occur. The light saturated growth rate, μ₀, is the rate of biomass accumulation under conditions of unlimited light availability. θ_g is a rate constant responsible for a milfoil growth rate that doubles with every 10° C increase in temperature (Herb and Stefan 2003). k₁, the half saturation constant for light, is the light intensity at which the photosynthetic rate proceeds at 50% of the maximum photosynthetic rate. The term also

includes parameters that limit light availability to the leaf surface; (K_{wt}), the light attenuation due to water clarity and (k_m), blockage of light by milfoil biomass. Irradiance at depth (I_d) and irradiance at the top of the milfoil stand (I_m) are considered separately, as irradiance levels are expected to be different at these locations in the water column (Herb & Stefan, 2006). Irradiance levels at the milfoil stand are dependent on total water depth (d) and water depth at the top of the milfoil stand ($d - h$):

$$I_m = I_0 e^{-K_{wt}(d-h)} \quad (3)$$

$$I_d = I_0 e^{-(K_{wt}d+k_m W)} \quad (4)$$

Where:

I_0 = light availability just below the water surface ($\mu\text{Em}^{-2}\text{s}^{-1}$)

h = average milfoil plant height (m)

2.2.2 Biomass loss due to respiration and autofragmentation

Biomass losses in the form of respiration (λ) and autofragmentation (δ) are represented by the following term in Equation 2:

$$(\lambda + \delta)W$$

Losses due to respiration are temperature dependent and correspond to the growth coefficient term ($\mu_0 \theta_r^{T-T_b}$) of Equation 2. Respiration losses were modeled as follows:

$$\lambda(t) = \lambda_0 \theta_r^{T-T_b} + \lambda_1 u_{t_e} \quad (5)$$

The term $\lambda_0 \theta_r^{T-T_b}$ is the respiration coefficient, composed of the coefficient for loss due to respiration (λ_0) and the respiration related temperature base (θ_r) which governs a doubling of the respiration rate with every 10°C increase in temperature (Herb and Stefan 2003) The final term in Equation 5, ($\lambda_1 u_{t_e}$) accounts for the expense of biomass to

carbohydrate conversion, where λ_1 is the rate of biomass loss and u_{t_e} is a step-function that controls the utilization of carbohydrates (u_{t_e} has a value of 0 or 1).

Biomass losses due to autofragmentation (δ) were modeled using the following equation:

$$\delta(t) = \gamma_1 u_{t_1} (1 - u_{t_2}) \quad (6)$$

γ_1 is the autofragmentation loss rate governed by step functions u_{t_1} and u_{t_2} . The step function values of either 0 or 1 control the start and end of the autofragmentation period. One autofragmentation period was thought to have occurred in 2014 in Christina Lake based on the Eurasian watermilfoil biomass observations (Chapter 3).

2.2.3 Early season biomass accumulation using non-structural carbohydrates

Early in the growing season, Eurasian watermilfoil shoots rapidly extend toward the water surface, a growth characteristic that results from the utilization of non-structural carbohydrates stored in the roots and stems over winter (Grace & Wetzel, 1978). Non-structural carbohydrate reserves (C) were modeled as a stock, using the following equation (Miller et al., 2011):

$$\frac{dC}{dt} = -\mu_2 (1 - u_{t_b}) C + u_{t_e} (\lambda_1 \frac{\mu_2}{\mu_1} W - \gamma_3 L) \quad (7)$$

Where:

μ_1 = rate of biomass production as the result of using stored energy (day^{-1})

μ_2 = rate of stored energy consumption (day^{-1})

γ_3 = rate of energy storage interruption by milfoil weevil larva ($\text{g DW day}^{-1} \text{ individuals}^{-1}$)

Distinct periods were defined for non-structural carbohydrate storage and utilization (Miller et al., 2011). The step function u_{t_b} controls the utilization of stored carbohydrates. During the carbohydrate utilization period, a value of 0 is assigned to the

step function which permits a draw from the carbohydrate pool. The step function u_{te} controls the storage of non-structural carbohydrates. During the period of carbohydrate storage, a value of 1 is assigned to this step function.

Non-structural carbohydrate storage is governed by the rate of biomass to carbohydrate conversion, λ_1 and the plant mass to carbohydrate conversion factor, $\frac{\mu_2}{\mu_1}$ (Miller et al. 2011). Interruption of carbohydrate storage by milfoil weevil larvae is factored into the equation using the term $\gamma_3 L$, the rate of energy storage interruption multiplied as a factor of the milfoil weevil larvae population.

In the biomass production model (Equation 2), the use of stored non-structural carbohydrates results in a net biomass gain and is governed by the previously described step function u_{tb} . During the early spring growth period, the step function value is 0, resulting in a biomass increase calculated as the product of the rate of biomass production using stored energy, μ_1 and the non-structural carbohydrate reserves, C:

$$\mu_1(1 - u_{tb})C$$

2.2.4 Biomass loss due to feeding and burrowing action of milfoil weevil larvae

The feeding and burrowing action of milfoil weevil larvae is modeled as a biomass loss in Equation 2. Biomass losses are calculated as the product of stem damage rate by milfoil weevil larvae, γ_2 and the weevil larvae population, L:

$$\gamma_2 L$$

2.2.5 Milfoil weevil larvae population

The milfoil weevil population model was constructed separately with the objective of mapping a change in weevil larvae population over time.

In laboratory studies, the time required to complete each stage varied with temperature. Mazzei et al. (1999) found that the mean number of days required to complete development ranged from 4.2 to 12 for eggs, 6.1 to 20 for larvae and 7.4 to 29 for pupa. These values are consistent with results of similar studies conducted by Tamayo and Grue (2004), Newman et al. (1997) and Roley and Newman (2006).

Mazzei et al. (1999) determined the lower temperature threshold for complete development (T_w) to be 9.8° C, with a minimum of 309.2 degree-days (DD). Details for each stage are located in Table 5. The base development rate (α_i) was calculated as the inverse of degree-days required for each development stage (Miller et al., 2011).

Table 5. Degree-days and base development rates for each stage of Euhrychiopsis lecontei development (Mazzei et al., 1999)

Stage	Cumulative degree-days required for development (CDD)	Degree-days required for development at each stage (DD)	Base development rate (α_i) (DD⁻¹)
Egg	78.0	78.0	0.0128
Larve	104.3	26.3	0.0380
Pupa	118.5	14.2	0.0704
Complete	309.2	-	-

Although all stages of the weevil lifecycle were modeled, the only stage that was integrated with the milfoil sub-model was the larva stage. Individual weevils enter the larva population pool by developing from the egg stage, and leave the larva pool by either dying or developing into pupa. The weevil lifecycle model is shown in Figure 10.

As previously described, the temporal scale of the model encompasses one growing season, from Spring to Fall when surface water temperatures are greater than 10 °C. It is assumed that any weevils entering the system from the overwintering period are negligible and the number of individuals in the weevil population starts with a value of zero.

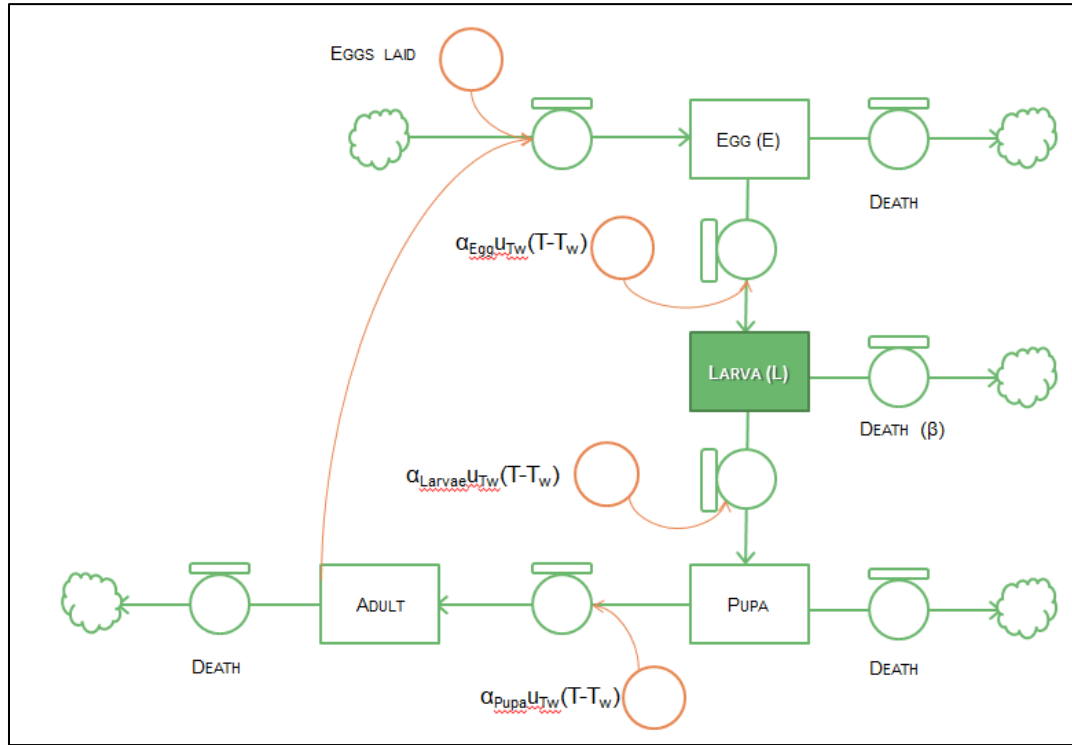

Figure 10. Milfoil weevil lifecycle model structure

Larva population growth was governed by the following equation (Miller et al. 2011):

$$\frac{dL}{dt} = E(\alpha_{Egg} u_{T_w}(T - T_w)) - (\beta_{Larvae} + \alpha_{Larvae} u_{T_w}(T - T_w))L \quad (8)$$

Where,

E = population of milfoil weevil eggs (individuals)

L = population of milfoil weevil larvae (individuals)

T = temperature (°C)

u_{T_w} = step function governing development (1 for $T \geq T_w$ and 0 otherwise)

α = base development rate ($DD^{-1} day^{-1}$)

β = death rate (day^{-1})

2.3 Data used as model inputs

Sources of data used as input for the model are described in Chapter 3. This section describes how data were incorporated into the weevil-watermilfoil biomass model and described calculations that were required to convert data into a useable form.

2.3.1 Surface water temperature

The mean daily temperature readings (Chapter 3) were imported into the model as graphical data (Figure 11). The lower threshold for complete weevil development (T_w), below which development of all life stages ceased completely was set at 9.8°C described by Mazzei et al. (1999). The lower threshold for milfoil development, base development temperature (T_b), was set at 10°C (Herb and Stefan, 2006). For a given day, if the difference between T and T_w/T_b was greater than zero, both weevil development and milfoil growth advanced. By comparing the minimum threshold temperature with the daily average surface water temperatures of Christina Lake, the growing season was defined as May 1 to November 6. The 189 day growing season was defined by ‘day of the year’ in the model, May 1 was Day 1 of the growing season and November 6 was Day 189.

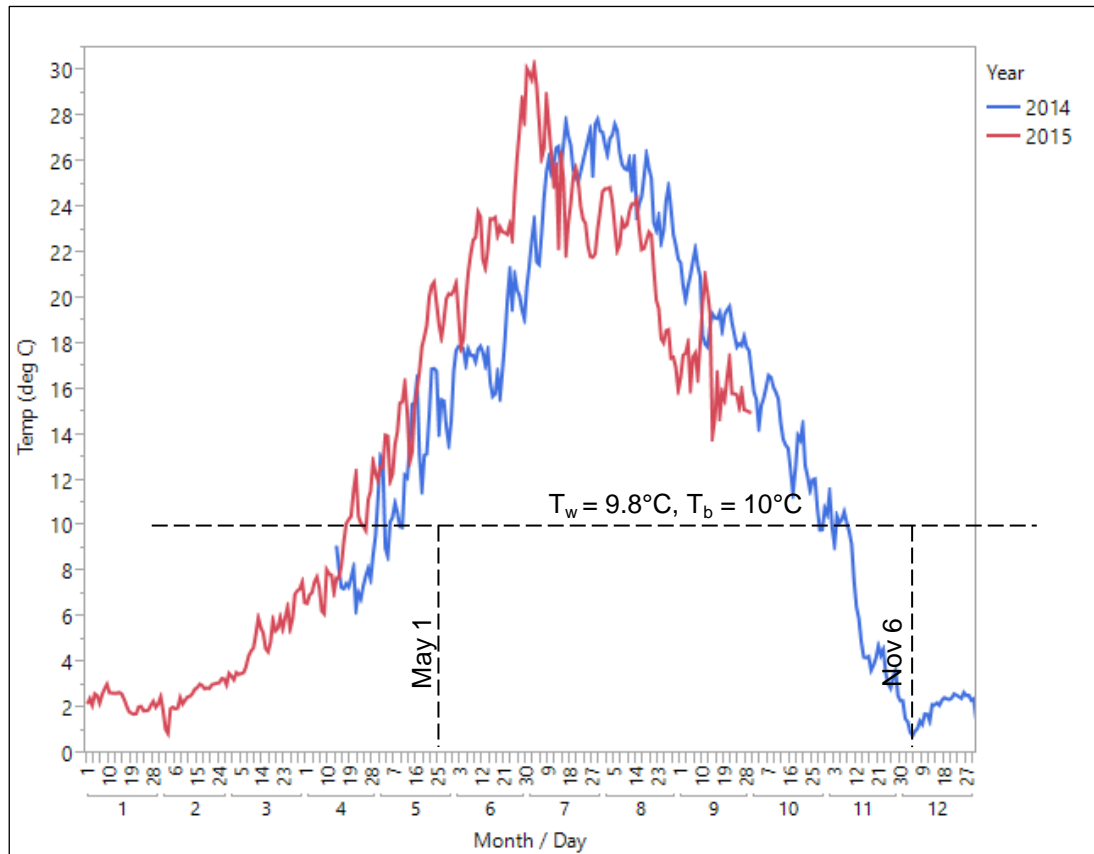

Figure 11. Mean daily surface water temperature, Christina Lake, B.C. south littoral zone, years 2014 and 2015

2.3.2 Irradiance

Light energy available for photosynthesis just below the water surface (I_0) was estimated using mean daily global insolation values provided by the Government of Canada (2014), as outlined in Chapter 3. Figure 12 shows the change in available light energy over the course of the growing season. The blue trend line represents I_s ($\mu\text{Em}^{-2}\text{s}^{-1}$), just above the water surface, whereas the red trend line represents I_0 ($\mu\text{Em}^{-2}\text{s}^{-1}$). The peak availability of light for photosynthesis, not taking into account attenuation due to water clarity or biomass, occurs between day 200 (July 19) and day 250 (September 7) of the year.

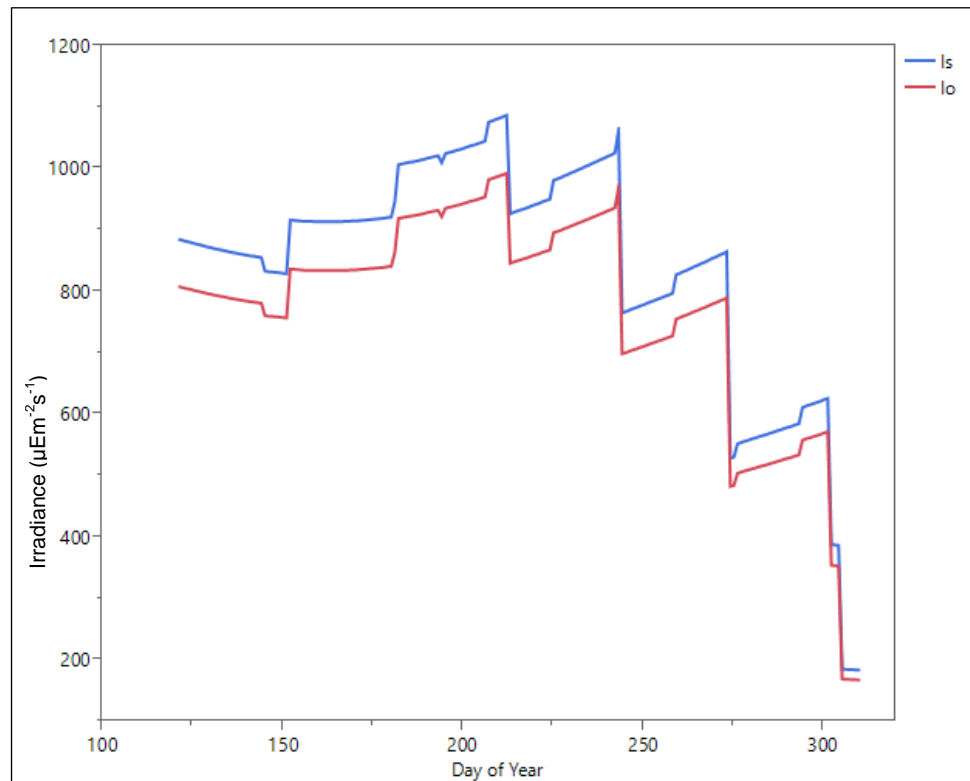

Figure 12. Calculated light energy available for photosynthesis ($\mu\text{Em}^{-2}\text{s}^{-1}$) above water surface (I_s) and just below water surface (I_o)

To determine I_0 , the mean daily global insolation values (Government of Canada, 2014) were transformed from kWhm^{-2} to Wm^{-2} . The mean daily global insolation values were divided by the photoperiod (day length), then multiplied by 1000 to convert to Wm^{-2} . To convert from Wm^{-2} to light available for photosynthesis (wavelength 400-700 nm), Combs (1977) method was used, where $1 \text{ Wm}^{-2} = 2.34 \mu\text{Em}^{-2}\text{s}^{-1}$. The following equation was used to calculate the light available for photosynthesis below the water surface (I_0) (Herb and Stefan, 2003), where the fraction reflected at the water surface (r) was assumed to be a constant value of 0.087 (Riley & Stefan, 1988):

$$I_0 = I_s(1 - r) \quad (9)$$

2.3.3 Water clarity

Water clarity influences the light attenuation coefficient for water (K_{wt}). Secchi disk depth (SDD) measurements collected by B.C. Environment over the period of 1972 to 1990 indicate high water clarity in Christina Lake (Ellis et al., 1991). The Secchi disk method for determining water clarity in freshwater involves lowering a standard black and white disk with a diameter of 20 cm (Figure 13) in the water column until it can no longer be visually distinguished from the surroundings. The depth at which this occurs is recorded and referred to as “Secchi disk depth.”

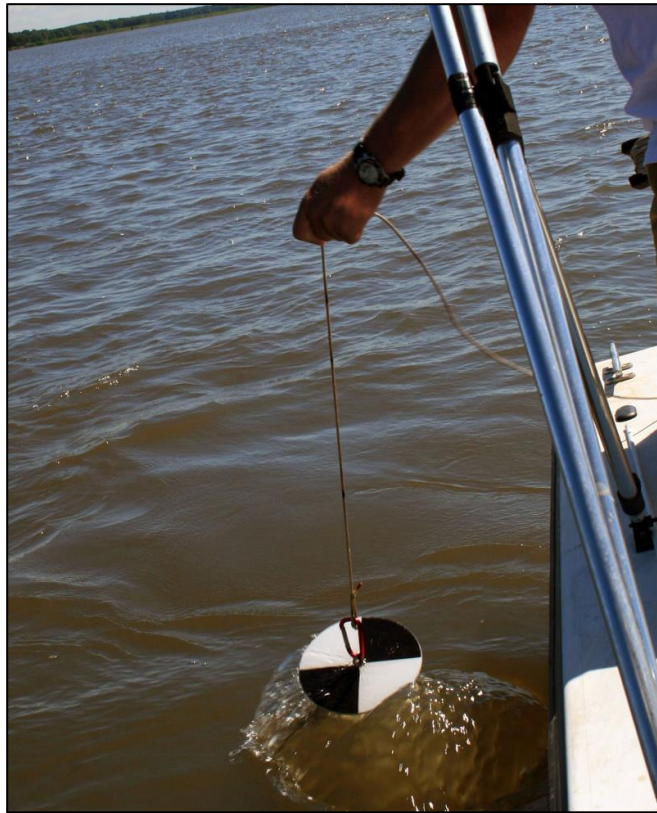

Figure 13. A standard Secchi disk for use in freshwater environments (UMCES, 2016)

SDD values from the South End sampling site ranged from 3.2 m to > 16 m. Table 6 provides a summary of SDD values (Ellis et al., 1991). Secchi disk readings were also reported by McGregor (1997) over the period of 1993 to 2004. Maximum and minimum

depth values were provided for the South End sampling site, but raw data were not available. The mean value of SDD measurements (10.3 m) from the earlier sampling period was used to estimate K_{wt} in Christina Lake using the equation (Poole & Atkin, 1929):

$$K_{wt} = \frac{1.7}{SDD} \quad (10)$$

Table 6. Christina Lake, B.C. Secchi Disk Depth (SDD) from the South End sampling station (0200078)

Parameter	Max	Min	Mean	N
Extinction depth (SDD) (m), 1971-1990 ²	> 16	3.2	10.3	30
Extinction depth (SDD) (m), 1993-2004 ³	13.5	7.5	not reported	13

2.3.4 Plant height

The base temperature for Eurasian watermilfoil growth (T_b) was described in the previous section as 10° C, occurring consistently after May 1. At this time, the overwintering milfoil shoots initiate growth and gain height throughout the growing season.

The milfoil sample collected on May 14, 2014 was taken to represent the overwintering condition of Eurasian watermilfoil in Christina Lake. The average plant height was 0.26 m (Table 7). For the purpose of the model, it was assumed that these heights represented the Eurasian watermilfoil throughout the entire study area. As the latest sample analyzed was August 10, 2014 and in some areas, natural senescence is known to initiate as early as mid-August (Reeves et al., 2008), this was taken to represent average maximum plant height in Christina Lake. Limited information is available on how plant height responds during the period of natural senescence. It is suspected that

² Ellis et al., 1991

³ McGregor, 2007

once natural senescence initiates, entire stems fall from the water column to the substrate at a rapid rate, leaving only the shorter stems to overwinter. For use in the model, natural senescence was estimated, and defined at the period extending from Day 243 (August 31) to Day 274 (October 1). Shearer (2010) monitored stem length of Eurasian watermilfoil throughout the year and found that by October, stems had reduced to lengths observed in early spring (May).

Table 7. Model input for Eurasian watermilfoil height (h) for Christina Lake, 2014

Date	n	Average stem length/height (m)	Std dev	Std error
May 30, 2014	28	0.260	0.071	0.013
June 14, 2014	26	0.333	0.111	0.022
July 1, 2014	18	0.532	0.249	0.059
July 28, 2014	12	0.606	0.249	0.072
August 10, 2014	21	0.688	0.396	0.086

2.3.5 Milfoil stem and biomass density

Biomass density, P_s , is the dry weight of the above-substrate milfoil plant matter over a base area of one square metre (g DW m^{-2}). To determine this value, the RDKB plant count data from 2014 was initially used to determine the mean stem density, δ_w , (plants m^{-2}) of each milfoil infestation level defined in Chapter 3 (high, moderate, low). Secondly, mean plant density was multiplied by the average biomass per plant to determine the mean biomass density over the course of the season (g DW m^{-2}) (Table 8).

Table 8. Mean stem (δ_w) and biomass (P_s) density for each infestation level in Christina Lake BC., 2014

Sample No.	Mass per stem (g DW)	Mean stem density, δ_w (plants per m ²)			Mean biomass density, P_s (g DW m ⁻²)		
		High	Mod.	Low	High	Mod.	Low
1	0.104	3.67	1.69	0.143	0.382	0.176	0.015
2	0.144	3.67	1.69	0.143	0.528	0.243	0.021
3	0.177	3.67	1.69	0.143	0.649	0.299	0.025
4	0.146	3.67	1.69	0.143	0.536	0.247	0.021
5	0.156	3.67	1.69	0.143	0.572	0.263	0.022

Herb and Stefan (2003, 2006) and Miller et al. (2011) use a value of 50 g DW m⁻² in their milfoil biomass models. As the average stem density (stems m⁻²) in the sites with high infestation levels have a value of only 3.67 plants m⁻², with an average maximum mass per plant of 177 mg DW, the biomass density number was reduced significantly to reflect the milfoil growth characteristic in the study area.

Milfoil stem density is also linked to the weevil population model and functions to limit resources available for population growth. Adult weevils select meristems for egg laying based on occupancy. Females will avoid egg laying sites that already contain eggs or larvae (Miller et al., 2011). Meristem availability is modeled as a function of milfoil stem density and biomass (W) based on the following equation:

$$\text{Available meristems} = \delta_w \theta_w^{W(t)} \quad (11)$$

Where,

θ_w = meristem count base (unitless)

2.3.6 Non-structural carbohydrates

Titus and Adams (1979) reported that total non-structural carbohydrates in overwintering milfoil in Lake Wingra, Wisconsin accounted for 20 % of the total plant

biomass. They determined that overwintering milfoil stored 10.8 g DW m^{-2} of non-structural carbohydrates. When applied to sites in Christina Lake with high milfoil infestation levels (average number of plants is 3.67 m^{-2}), we would expect the average early season total biomass to be only $0.382 \text{ g DW m}^{-2}$. The non-structural carbohydrate storage is expected to be $0.076 \text{ g DW m}^{-2}$. This value was used as a model input for the initial non-structural carbohydrate value.

Table 9. Parameters, variables, constants and values used for the simulation model, adapted from Miller et al., 2011

Parameters, variables	Model Symbol	Value	References
Eurasian watermilfoil base growth rate	μ_0	0.09 1 day ⁻¹	Best & Boyd, 1999
Irradiance half saturation constant	k_1	365 $\mu\text{Em}^{-2}\text{s}^{-1}$	Titus & Adams, 1979
Growth related temperature base	θ_g	1.06 unitless	Herb & Stefan, 2006
Base temperature	T_b	10° C	Herb & Stefan, 2006
Light attenuation due to water clarity	K_{wt}	0.165 1 m ⁻¹	Field data
Light attenuation due to blockage by biomass	k_m	0.006 m ² g ⁻¹ DW	Herb & Stefan, 2003, 2006 Titus et al., 1975
Rate of biomass production as a result of using stored energy	μ_1	0.4 1day ⁻¹	Miller et al., 2011
Rate of stored energy consumption	μ_2	0.08 1 day ⁻¹	Miller et al., 2011

Parameters, variables	Model Symbol	Value	References
Time at which use of energy reserves ends (day)	t_b	June 29 Day 59 of season	Miller et al., 2011
Time at which storage of energy reserves begins (day)	t_e	August 28 Day 119 of season	Miller et al., 2011
Time at which autofragmentation period starts (day)	t_1	July 1 Day 61 of season	Field data
Time at which autofragmentation period ends (day)	t_2	July 21 Day 81 of season	Titus et al., 1975 Adams & McCracken, 1974 Smith & Barko, 1990
Respiration related temperature base	θ_r	1.072 unitless	Herb & Stefan, 2006
Coefficient for loss due to respiration	λ_0	0.019 1 day ⁻¹	Best & Boyd, 1999
Rate of biomass loss due to actively storing reserved energy	λ_1	0.01 1 day ⁻¹	Miller et al., 2011
Autofragmentation loss rate	γ_1	0.05 1 day ⁻¹	Titus et al., 1975 Adams & McCracken, 1974 Smith & Barko, 1990
Rate of stem damage by <i>E. lecontei</i> larva	γ_2	0.0233 g DW day ⁻¹ individuals ⁻¹	Mazzei et al., 1999
Rate of energy storage interruption by <i>E. lecontei</i> larva	γ_3	0.00001 g DW day ⁻¹ individuals ⁻¹	Miller et al., 2011 Newman et al., 1996
Death rate for eggs	β_{Egg}	0.0427 1 day ⁻¹	Mazzei et al., 1999, Newman et al., 1997
Death rate for larva	β_{Larva}	0.0152 1 day ⁻¹	Mazzei et al., 1999, Newman et al., 1997

Parameters, variables	Model Symbol	Value	References
Death rate for pupa	β_{Pupa}	0.0280 1 day ⁻¹	Mazzei et al., 1999, Newman et al., 1997
Death rate for adults	β_{Adult}	0.0231 1 day ⁻¹	Mazzei et al., 1999, Newman et al., 1997
Base development rate for eggs	α_{Egg}	0.0128 DD ⁻¹ day ⁻¹	Mazzei et al., 1999
Base development rate for larva	α_{Larva}	0.0380 DD ⁻¹ day ⁻¹	Mazzei et al., 1999
Base development rate for pupa	α_{Pupa}	0.0700 DD ⁻¹ day ⁻¹	Mazzei et al., 1999
Min. temperature for complete development	T_w	9.8 °C	Mazzei et al., 1999
Base egg laying rate	α_0	1.9 female ⁻¹ day ⁻¹	Cofrancesco & Crosson, 1999
Egg laying half saturation temperature	k_2	20 °C	Cofrancesco & Crosson, 1999
Meristem count base	θ_w	1.0018 unitless	Miller et al., 2011
Stem density	δ_w	3.5 stems m ⁻²	Field data
Stand density	P_s	0.941 g DW m ⁻²	Field data
Depth of canopy	b_c	0.20 m	Miller et al., 2011
Water depth	d	2 m	Field data
Initial Eurasian watermilfoil biomass	W_0	0.50 g DW m ⁻²	Field data

Parameters, variables	Model Symbol	Value	References
Eurasian watermilfoil height	h	Graphical input, metres	Field data
Initial Eurasian watermilfoil stored carbohydrates	C ₀	0.076 g DW m ⁻²	Field estimate
Surface water temperature	T	Graphical input, °C	Field data
Irradiance below water surface	I ₀	μEm ⁻² s ⁻¹	Government of Canada, 2014
Controls utilization of stored carbohydrates	μ _{tb}	0 if t < t _b 1 if t ≥ t _b	Miller et al., 2011
Controls storage of carbohydrates	μ _{te}	0 if t < t _e 1 if t ≥ t _e	Miller et al., 2011
Controls start of autofragmentation	μ _{t1}	0 if t < t ₁ 1 if t ≥ t ₁	Miller et al., 2011
Controls end of autofragmentation	μ _{t2}	0 if t < t ₂ 1 if t ≥ t ₂	Miller et al., 2011
Controls weevil development	μ _{Tw}	1 if T ≥ T _w 0 if T < T _w	Miller et al., 2011

2.4 Results

STELLA© modeling software was used to estimate the milfoil biomass accumulation over a base area of 1 m². The model was set to run over the 189-day growing season from May 1 to November 6. The delta time interval (DT) was adjusted to 0.5 days; this value provided acceptable model performance while maintaining output similar to simulations with higher calculation frequencies (smaller time intervals). The Runge-Kutta 4th-order integration method was selected to solve differential equations in the model. Initially, the number of milfoil weevils in the system was set at zero.

When variables from Christina Lake (irradiance, surface water temperature, milfoil characteristics) were used as model inputs with Miller et al. (2011) parameter values, the resulting milfoil biomass was significantly higher than expected, with the maximum value nearing 2500 g DW m⁻² (Figure 14).

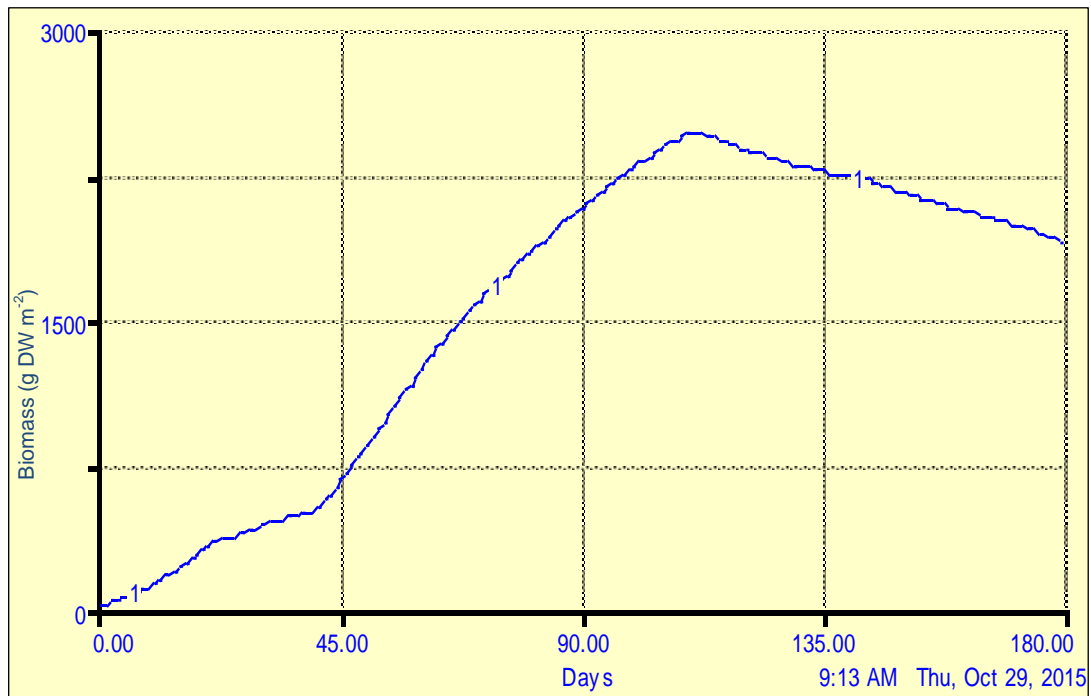

Figure 14. Modeling software output, milfoil biomass prior to adjusting model parameter values

The values of the model parameters were reviewed, and the following changes were made to more closely represent the conditions of Christina Lake. Eurasian watermilfoil base growth rate μ_0 was decreased from 0.10 to 0.05 1 day⁻¹. In the primary simulation, with a base growth rate of 0.10 1 day⁻¹, it was assumed that available mineral nutrients and inorganic carbon were not limiting to milfoil growth. Previous studies (McGregor 2005) classify Christina Lake as oligotrophic with evidence that cultural eutrophication may be occurring. Although nutrients in the water column are used to characterize trophic status, if the oligotrophic state of Christina Lake is extended beyond

the water column to the sediment, from which Eurasian watermilfoil draws most of the mineral nutrients required for growth, we could expect the base growth rate of milfoil to be low. Nuisance levels of milfoil growth are associated with nutrient-rich, relatively alkaline lakes; therefore, it is possible that an overestimation of milfoil biomass could be attributed to the assumption of unlimited nutrient and inorganic carbon availability. Limited availability of nutrients and carbon would decrease the base growth rate of Eurasian watermilfoil. Figure 15 represents the accumulation of watermilfoil biomass over a season, under varying values of the base growth rate, μ_0 , from 0.05 to 0.20 1 day⁻¹.

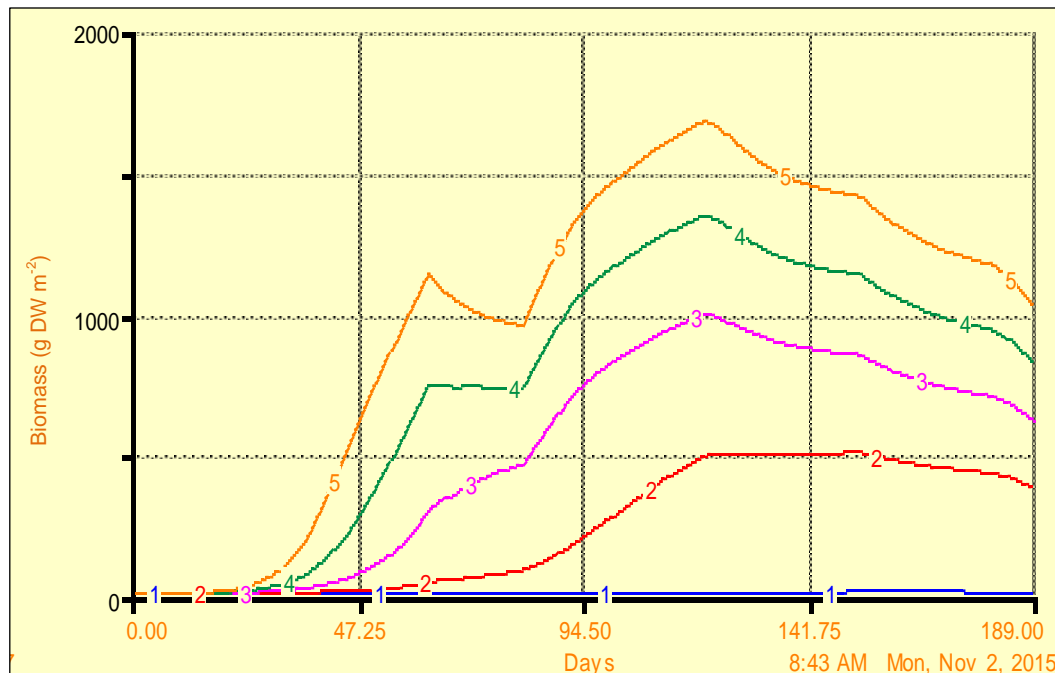

Figure 15. Response of milfoil biomass accumulation under milfoil base growth rates varying from 0.05 to 0.20 1 day⁻¹

Literature values for Eurasian watermilfoil growth rate range from 0.09 to 0.18 per day (Madsen et al., 1991; Best & Boyd, 1999; Van et al., 1976), with the highest value at 30 °C, under saturated light and carbon conditions (Van et al., 1976). Lowest

values reflect temperatures at 20 °C, under carbon-limited conditions. Table 10 summarizes the results.

Table 10. Model output for maximum biomass under different milfoil growth rate values

Scenario No.	Milfoil base growth rate, μ_0 (1 day⁻¹)	Maximum milfoil biomass accumulation (g DW m⁻²)	Comments
1	0.050	10	Most representative of Christina Lake biomass conditions
2	0.088	507	μ_0 value used by Best and Boyd (1999), for 20° C, carbon limited environment
3	0.125	989	μ_0 value used by Madsen et al. (1991), for 20° C environment
4	0.163	1348	μ_0 value of 0.18 used by Van et al. (1976), for 30° C, light and carbon saturated environment
5	0.200	1683	

The irradiance half saturation constant, k_1 , was increased to 365 $\mu\text{Em}^{-2}\text{s}^{-1}$. Titus and Adams (1979) reported the range for this parameter as 164-365 $\mu\text{Em}^{-2}\text{s}^{-1}$. High values are more representative of plants found in clear water in areas of solar radiation, typical of Christina Lake.

The coefficient for loss due to respiration, λ_0 , was decreased to 0.019 1 day⁻¹ (Best & Boyd, 1999), representative of conditions with lower temperature and carbon availability.

When the simulation model was re-run with the described parameter adjustments, the maximum milfoil biomass value of 10 g DW⁻² is more typical of what we can expect for Christina Lake, based on field observations (Chapter 3). The peak biomass

in the simulation does not occur until Day 152 of the growing season (September 30), prior to the period of natural senescence (Figure 16).

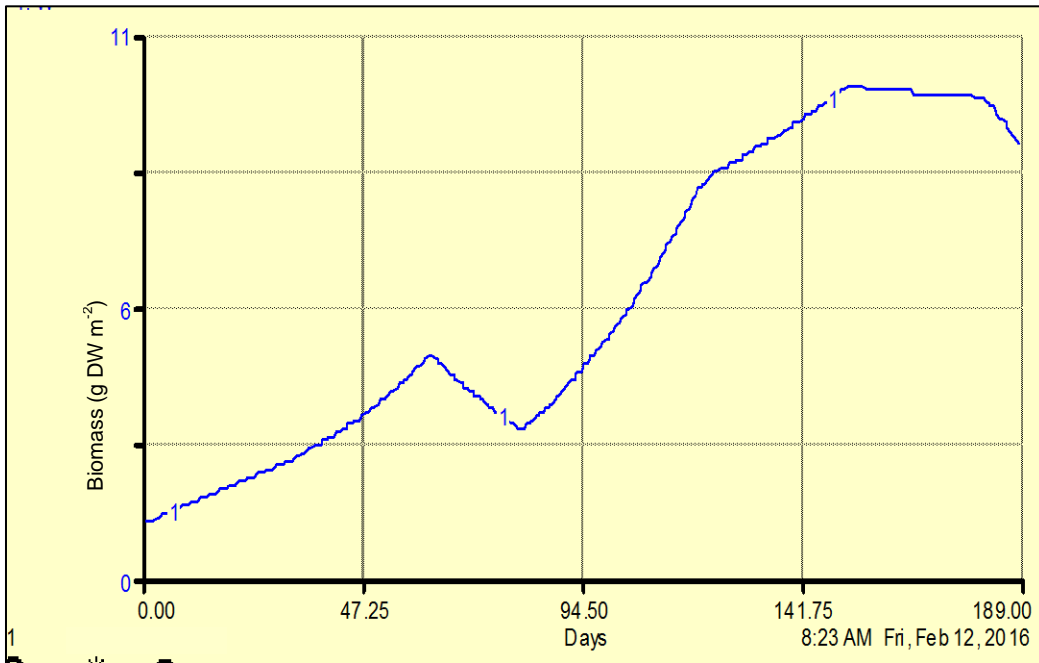

Figure 16. Model output for biomass accumulation after parameter values were manipulated to represent conditions of Christina Lake

2.4.1 Weevil augmentation scenarios

To test the response of peak milfoil biomass (g DW m^{-2}) to augmentation with weevils, simulations were done where varying weevil numbers were added to the system. Weevils were introduced to the system on the first day of the growing season, May 1. Figure 17 shows the response of the milfoil biomass over the course of the growing season.

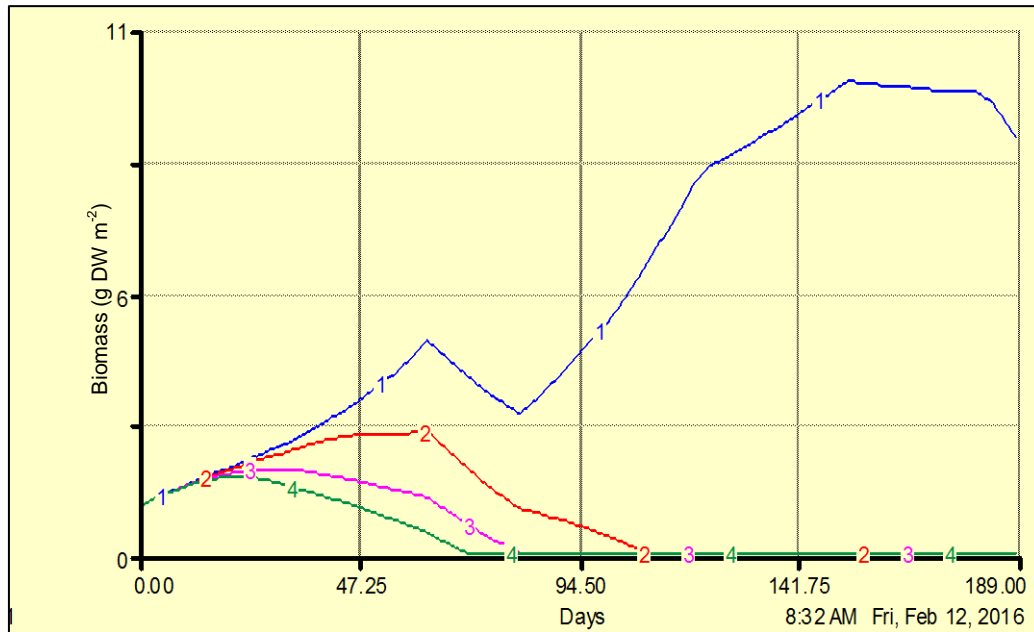

Figure 17. Milfoil biomass response to different weevil augmentation scenarios (0, 1, 3 and 5 adult weevils m^{-2})

Scenario 1 simulates uncontrolled milfoil growth throughout the growing season, while scenario 2 shows the addition of 1 weevil m^{-2} . Scenario 3 and 4 represent the addition of 3 and 5 weevils m^{-2} , respectively. When as few as 1 weevils m^{-2} are added to the system, the simulation shows a reduction in peak milfoil biomass, leading to a crash by day 140 of the season (September 18). As more weevils are added to the system, the milfoil biomass crash occurs earlier in the growing season. In scenario 4, with the addition of 5 weevils m^{-2} , the simulated milfoil biomass experiences a crash on day 83 of the growing season (July 23) (Table 11).

Table 11. Model output for maximum milfoil biomass accumulation and date of biomass crash for weevil augmentation scenarios ranging from 0 to 5 adult weevils per square metre

Scenario No.	No. of adult weevils introduced	Maximum milfoil biomass accumulation (g DW m⁻²)	Biomass crash date
1	0	10	NA
2	1	3	September 18
3	3	2	August 5
4	5	2	July 23

As an example, the simulation model can be applied to a milfoil management scenario that targets the highly infested milfoil sites in Christina Lake. The approximate total area of sites classified as “high” level of milfoil infestation in 2014 (Appendix A) was 97,000 m². Using the model output, we decide that an augmentation rate of 1 weevil per m⁻² should provide the desired level of milfoil control. This augmentation rate translates into the requirement for 97,000 adult weevils to be distributed throughout the “high” infestation sites.

2.5 Assumptions

A number of assumptions were made when developing the milfoil biomass and weevil population sub-models. Surface water temperature and milfoil respiration coefficients were treated as constant values throughout the depth profile (0 to 2 m). Light attenuation due to water clarity was a constant value and did not change over the course of the season, although changes could be expected with seasonal changes in the phytoplankton community and sedimentation during runoff.

For the weevil population sub-model, it was assumed that weevils were not subject to predation, parasites or other diseases. Additionally, migration and emigration were not included as factors in the model; weevils can only enter the system through

augmentation activities and the only method for weevils to leave the population is through death. In terms of weevil development, an upper threshold for temperature was not set, as water temperatures do not encroach on the value ($>35\text{ }^{\circ}\text{C}$). Additionally, the development rate for each life stage follows a linear trend, whereas more sophisticated methods for mapping development rate may provide more accurate population dynamics.

CHAPTER 3–FIELD DATA USED FOR SIMULATION MODEL

3.1 General description of the study site

The model described in Chapter 2 was designed to simulate the level of Eurasian watermilfoil control in Christina Lake as a result of milfoil weevil augmentation.

Christina Lake is located in the Southern Interior region of British Columbia. Christina Lake is a recreation destination, heavily used in the summer for boating, swimming and fishing. The number of residents increases five-fold during July and August (Cavanagh, 1994), primarily due to the return of seasonal residents and tourists.

The Lake is approximately 20 km in length, north-south in orientation (Aquatic Resources Ltd., 2000; Cavanagh, 1994). Because the lake bottom is glacially-carved and steeply U-shaped, only five percent of the lake's area is occupied by a littoral zone, the majority of which is located adjacent to the southeast shore of the lake (Cavanagh, 1994). The lake is strongly stratified during the summer months. Surface water temperatures typically peak in August to a maximum of approximately 25 °C (Cavanagh, 1994).

From Christina Lake, water flows into Christina Creek before entering the Kettle River. The Kettle River enters the U.S.A. approximately 3.75 km downstream of the confluence. Near Kettle Falls, Washington, the Kettle River and Columbia River converge at Franklin D. Roosevelt Lake.

Christina Lake is an ecologically important lake. It supports one of the most diverse fish assemblages in British Columbia (Aquatic Resources Ltd., 2000), with a confirmed record of 19 different species and potential for an additional 14 species present in the tributaries and Kettle River system (Christina Lake Stewardship Society, 2009). Largemouth bass (*Micropterus salmoides*), pumpkinseed sunfish (*Lepomis gibbosus*) and to a lesser extent smallmouth bass (*Micropterus dolomieu*) are found to be associated

with the macrophyte beds at the lake's north and south ends (Aquatic Resources Ltd., 2000). Two groups of kokanee salmon (*Oncorhynchus nerka*) with different life histories are found in Christina Lake. The shore-spawning population are native to Christina Lake, while the stream-spawning kokanee were introduced in the 1930s and 1940's from Kootenay Lake, B.C.

The north portion of the lake, approximately half of the lake's shoreline, is within Gladstone Provincial Park (Aquatic Resources Ltd., 2000). As a substantial area of the lakeshore is inaccessible by vehicle, much of the adjacent land provides important habitat for wildlife (Cavanagh, 1994).

Water quality data collected by the Province of B.C. indicate that Christina Lake is in an oligotrophic state and the overall water quality is very good (Cavanagh, 1994). Although still classified as oligotrophic, phytoplankton indicators suggest the lake may be in the early stages of eutrophication (McGregor, 2007).

Relatively wide littoral zones are located at the south and north ends of Christina Lake have historically supported a moderately dense and diverse native macrophyte community. Surveys conducted in the 1970's by the Ministry of Environment document the macrophyte species present in Christina Lake prior to Eurasian watermilfoil introduction. At that time, 54 species were identified (Cavanagh, 1994).

3.2 Sources of data used for the simulation model

The sources of data used for the model are identified in Table 12. Local datasets were used as inputs for the simulation model, representative of the environmental and Eurasian watermilfoil characteristics of Christina Lake. Existing datasets were used where available, for example, Government of Canada datasets were used for solar

radiation. Data on Eurasian watermilfoil (height, density, biomass) and surface water temperature were collected from the study area.

Table 12. Datasets used for development of the simulation model

Dataset	Source	Purpose	Reference
Eurasian watermilfoil plant counts, 2012, 2013, 2014	RDKB	Map coverage of throughout the lake, plant density	RDKB milfoil control program, 2012, 2013, 2014
Average Eurasian watermilfoil biomass per plant (g DW) (2014)	Field data	Initial biomass value, auto-fragmentation period	
Average Eurasian watermilfoil stem length (cm), 2014	Field data	Initial height value	
Existing <i>E. lecontei</i> population, 2013, 2014	Field observations	Initial population value	
Surface water temperature (°C), hourly readings, 2014 and 2015	Field data	Main driver for weevil development and Eurasian watermilfoil growth	
Water depth (m)	Bathymetric map of Christina Lake	Model input	Government of British Columbia, 1952
Solar radiation (kWh/m ²), daily average, reported monthly over the course of a year	Christina Lake solar insolation	Model input, used to determine photosynthetically active radiation at the milfoil stand height	Government of Canada, 2014

3.2.1 Eurasian watermilfoil coverage

An integral part of the Regional District of Kootenay Boundary (RDKB) Eurasian watermilfoil control strategy for Christina Lake is their team of professional SCUBA divers. Each year, from May through late fall, the divers perform control activities where

Eurasian watermilfoil is targeted, removed and disposed. In recent years, two teams of divers have been utilized, which have enabled effective lake-wide control. The divers are trained in plant identification and follow a standard method during control activities.

The SCUBA dive team aims to remove all Eurasian watermilfoil plants from a site. When dealing with very large stands, it is not feasible to completely remove the Eurasian watermilfoil in one session; the time required would compromise control at other sites. In these cases, heavily infested sites are visited up to three times a year to control the infestation level to site-specific objectives, i.e. clearing areas for swimming or around docks.

Eurasian watermilfoil control sites are located around the entire perimeter of the lake, with the exception of the southeast corner near the outflow at Christina Creek. This site is excluded from control activities as it harbours a population of native plant species with relatively low Eurasian watermilfoil abundance (Personal comm. Andrew Gilmore, 2013). In an effort to protect the native plant community in this area, buoys are placed around the perimeter to stop boat traffic from entering. This prevents disruption to the plants and also curtails the transport of Eurasian watermilfoil fragments into the area by boat propellers. Prior to 2012, 195 Eurasian watermilfoil control sites were established. In 2013, the number of Eurasian watermilfoil control sites increased to 575. Figure 18 shows the Eurasian watermilfoil control sites distributed throughout the littoral zone of the lake. Each numbered site encompasses the littoral area between 1–4 m depth and the width of the adjacent parcel of land, or as described by the milfoil control dive team. Although in some cases Eurasian watermilfoil can be found in water depths up to 10 m, the zone between 1 and 4 m was used to delineate the control areas, as it represents the optimum depth for Eurasian watermilfoil growth (Smith & Barko, 1991).

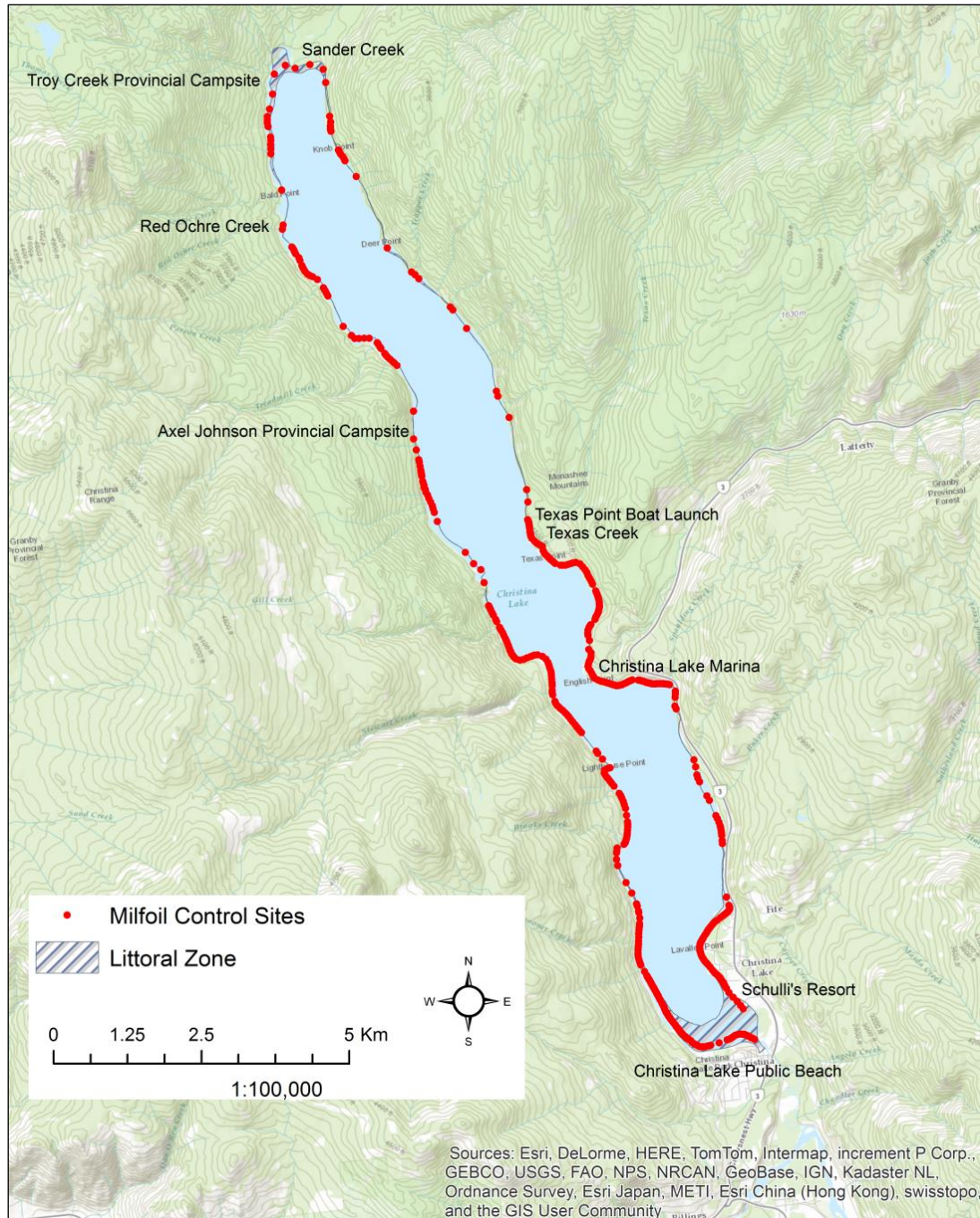

Figure 18. RDKB Eurasian watermilfoil control site distribution, Christina Lake, B.C. (2014, 2015)

Areas of the lake that were not yet assigned a Eurasian watermilfoil control site number were assumed to lack Eurasian watermilfoil growth, as the lake is constantly

being monitored for new infestations by property owners, lake users and the RDKB dive team.

Upon arriving at a site, the dive team performs a visual assessment of the Eurasian watermilfoil infestation level. The Eurasian watermilfoil is picked by hand, one plant at a time and care is taken to remove the entire plant and root mass. The detached plants are placed in mesh bags and brought to surface. From there, plants are stockpiled in large containers on the dive boat. At the end of the shift, or as required, these containers are brought to the disposal location where plants are composed for use as a soil amendment. Removed plants are tallied by each diver and numbers are recorded in a log book at the end of each dive.

Data from the dive team for the years 2012 through 2014 were obtained to gain a perspective on the Eurasian watermilfoil abundance throughout the lake. Infestation levels were designated by the diver control effort (Table 13) - total number of Eurasian watermilfoil plant removed from each site over the year.

Table 13. Classification of Eurasian watermilfoil control areas by infestation level

Infestation Level	Number of Eurasian watermilfoil plants removed per year
High	> 4,999
Moderate	100 – 4,999
Low	< 100
None	0

ArcGIS was used to define the littoral zone and delineate the area of each control site. The bathymetric map produced by the British Columbia Fish and Game Branch (1952) was used as the base data layer for these analyses.

Figures 19 and 20 show the Eurasian watermilfoil control sites for the south and north ends of Christina Lake, with the infestation levels for 2012, 2013, and 2014. The sum of the areas of each infestation level was calculated (Table 14). The remaining sites that aren't shown in Figures 19 or 20 are located along the central east and west shorelines. Although not mapped, these polygons are included in the calculations. Most of the east and west shorelines are steep, the littoral zone is very narrow and provides limited habitat for Eurasian watermilfoil growth. There are a few exceptions; moderate Eurasian watermilfoil infestation levels can be seen in bays where the littoral zone is more extensive and surrounding the public boat launch at Texas Point.

Over the three years evaluated, sites with high infestation levels were concentrated in the southeast portion of the lake. Other sites with high infestation levels were observed at the north end of the lake (one in 2013 and 2014) and in the area of the Texas Creek public boat launch (one in 2013).

The total optimum depth zone for Eurasian watermilfoil growth (1–4 m) of Christina Lake was calculated to be approximately 48 hectares. In 2012, the established Eurasian watermilfoil control sites covered an area of approximately 19 hectares of this zone. With the addition of new Eurasian watermilfoil control sites in 2013, the Eurasian watermilfoil control sites covered approximately 34 hectares.

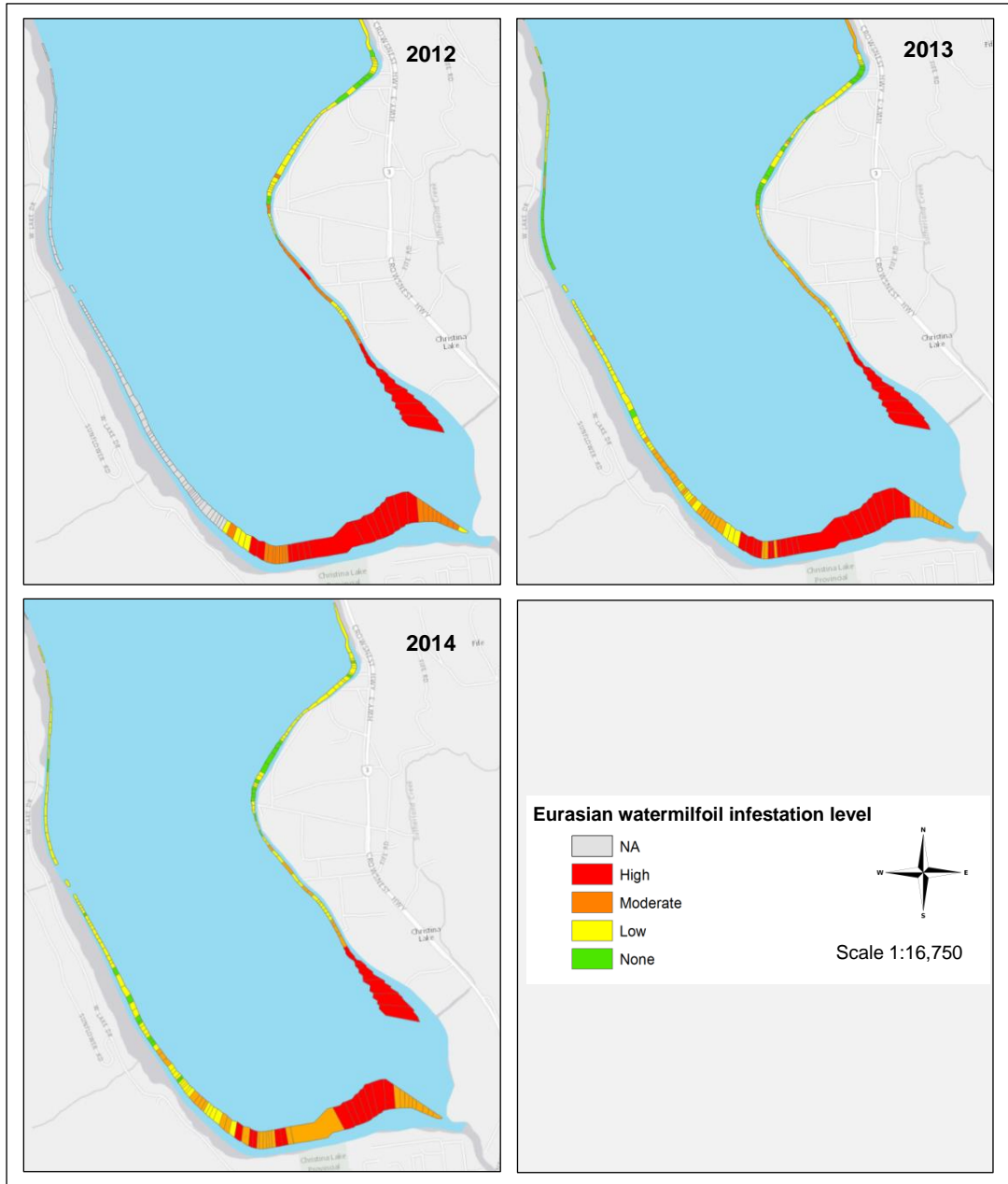

Figure 19. Infestation levels observed at the Eurasian watermilfoil control sites in the south end of Christina Lake, B.C. by level of diver control effort for the years 2012, 2013 and 2014

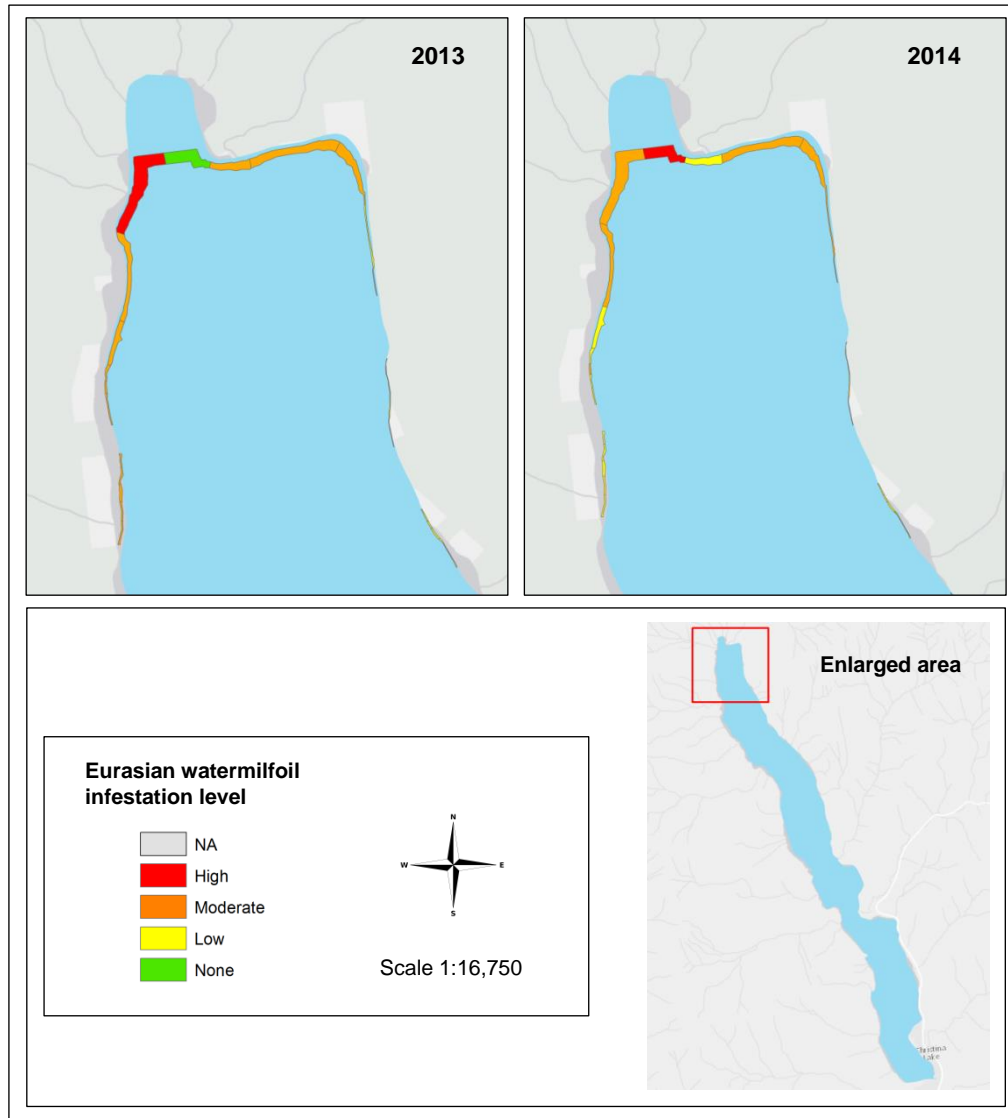

Figure 20. Infestation levels observed at the Eurasian watermilfoil control sites in the north end of Christina Lake B.C. by level of diver control effort for the years 2013 and 2014

Table 14. Cumulative areas of the Eurasian watermilfoil infestation levels within the Eurasian watermilfoil control zone of Christina Lake, B.C. from 2012 to 2014

	2012		2013		2014	
Infestation Level	Area (ha)	Proportion of area	Area (ha)	Proportion of area	Area (ha)	Proportion of area
High	11.96	0.64	14.48	0.43	9.69	0.29
Moderate	3.17	0.17	8.54	0.25	11.02	0.33
Low	2.87	0.15	6.83	0.20	10.50	0.31
None	0.63	0.03	3.71	0.11	2.36	0.07
Total	14.95	1.00	33.57	1.00	33.57	1.00

In 2012, approximately 12 hectares of the Eurasian watermilfoil control zone in Christina Lake was classified as “high” infestation level. This accounted for 64% of the Eurasian watermilfoil control zone. “Moderate” and “low” infestation levels accounted for 17% (3.17 hectares) and 15% (2.87 hectares), respectively (Table 14).

With the addition of new Eurasian watermilfoil control sites in 2013, the proportion of the area classified as “high” infestation decreased to 43%, even though the area increased to approximately 14.5 hectares. Sites of “moderate” infestation levels accounted for 25% of the area (8.54 hectares), while “low” infestation sites increased to 20% (6.83 hectares). The proportion of areas with no Eurasian watermilfoil observations increased to 11% (3.71 hectares).

In 2014, a decrease in the area classified as “high” level infestation was observed, accounting for 29% of the control zone (9.69 hectares). “Moderate” sites increased to 33% of the total control zone (11.02 hectares) and “low” sites increased to 31% (10.50 hectares). Sites with no observed Eurasian watermilfoil decreased to 7% of the control zone (2.36 hectares) (Figure 21).

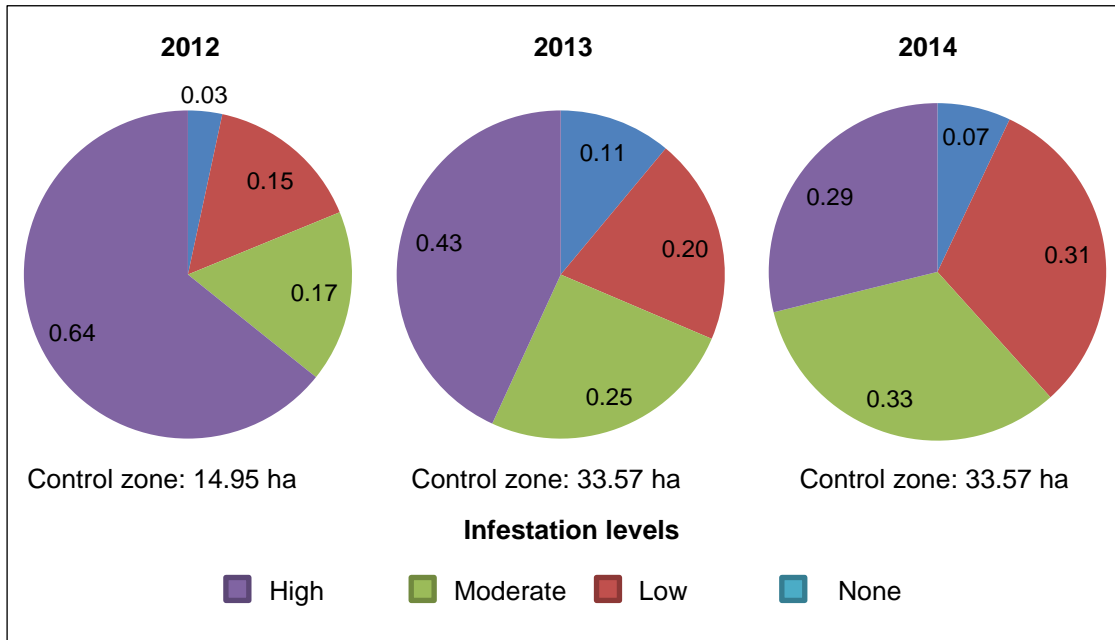

Figure 21. Proportion of the levels of Eurasian watermilfoil infestations within the control zone of Christina Lake, B.C. from 2012 to 2014

3.2.2 Eurasian watermilfoil biomass and stem length (height)

Eurasian watermilfoil biomass is an important component of the simulation model. An initial biomass estimate was required as an input, to account for the evergreen overwintering portion of the plant from which new growth stems in the spring.

Samples of Eurasian watermilfoil were collected at approximately two week intervals from May through September 2014. Sampling events were conducted in conjunction with the SCUBA divers while performing Eurasian watermilfoil control activities. Once Eurasian watermilfoil plants were harvested and brought to surface, a random sample of approximately 100 plants was collected and placed in a large Ziplock™ bag. The bags were marked with site information and placed in a cooler for transport, then placed in a freezer for storage. In some cases, where divers were working in small sites with low infestation levels, multiple locations were included in a single sample. All sites making up a sample were recorded.

Samples were thawed to room temperature in a laboratory setting. Once thawed, each sample was emptied into a sieve where it was carefully rinsed with water to remove sediment, algae, and invertebrates. Water was allowed to drain from the plants and material that was rinsed from the plants was examined for invertebrates. Plants were teased apart with an aim of segregating 30 entire plants from the sample for analysis. Plants that did not have both the root portion and meristems were discarded and not used in the analysis. Once suitable plants were identified, the below-ground structures were removed at what was the sediment-water interface. The length of each plant was recorded, as were any indications of invertebrate herbivore activity such as bore holes or missing stem and leaf tissue. Plants comprising separate samples were placed in a clean, pre-weighed aluminum pans and weighed on an electronic top-loading scale. Pans were placed in an oven set at 105° C and left to dry for 48 hours. After 48 hours, the pans containing dry samples were immediately weighed and the mass (g DW) was recorded. Dry weight was determined for each sample by subtracting the pan mass from the final mass.

Samples were collected from sites throughout Christina Lake. Samples were obtained by the SCUBA divers during Eurasian watermilfoil control activities. Site locations from which samples were collected are shown in Figure 22.

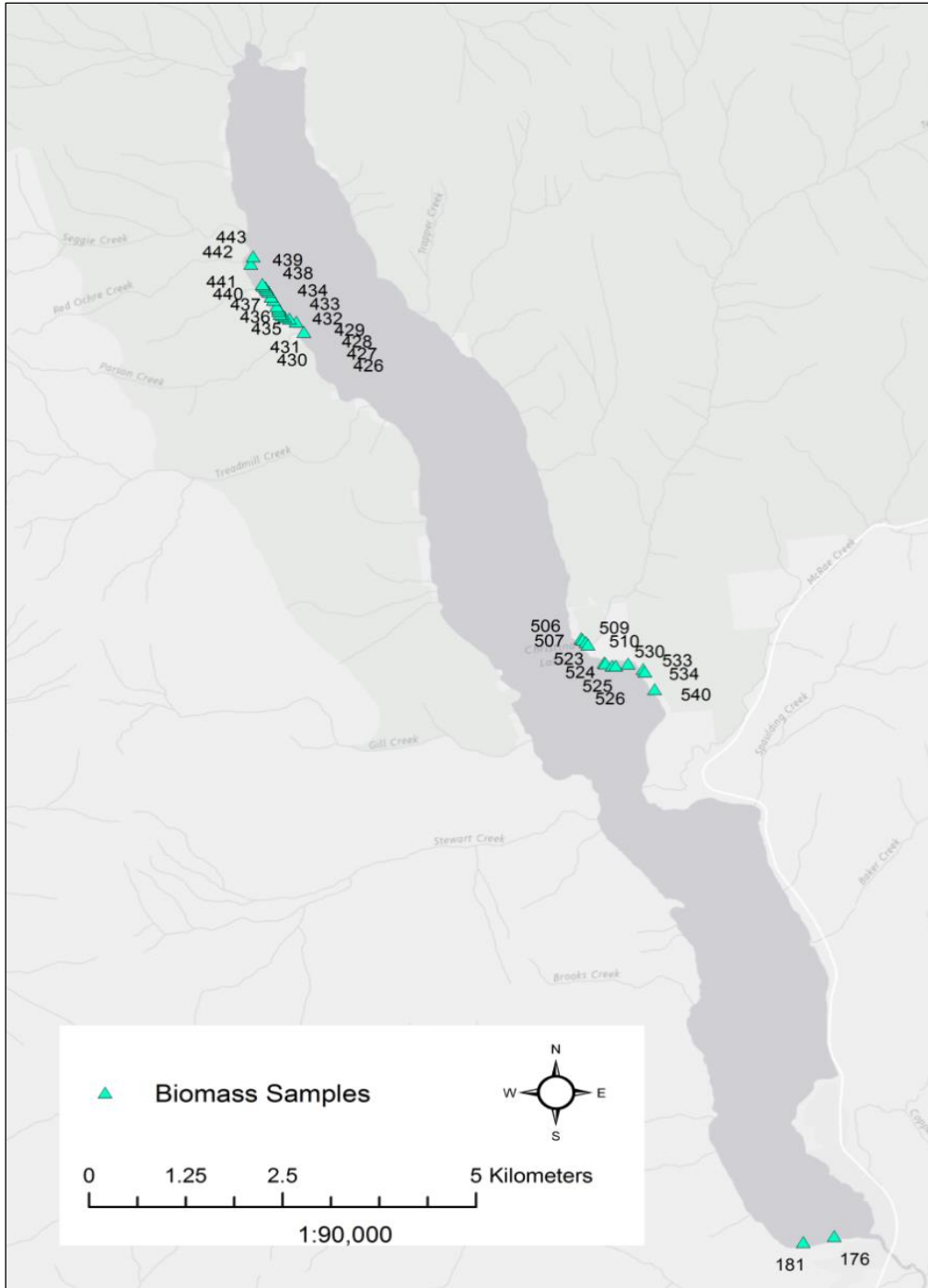

Figure 22. Eurasian watermilfoil sample collection locations for biomass analysis, Christina Lake, B.C

Stems of the Eurasian watermilfoil from a sample collected on July 14, 2013 were fragmented and appeared to have been degraded. Possible reasons for this may be due to a substantial amount of organic sediment collected with the rooting material, or plants may have desiccated prior on placement in the sample bag. This sample was discarded and not included in the biomass assessment.

Table 15. Average biomass of Eurasian watermilfoil plants in Christina Lake, B.C. from May to August 2013

Date	Site(s)	Stems (n)	Dry mass (g)	Avg stem length (cm)	Avg mass per stem (g/stem)
May 30, 2014	181	28	2.90	26.0	0.104
June 14, 2014	176	26	3.75	33.3	0.144
July 1, 2014	506, 507, 509, 510, 523-526, 530, 533, 535, 540	18	3.18	53.2	0.177
July 14, 2014	-	-	-	-	-
July 28, 2014	534	12	1.75	60.6	0.146
Aug 10, 2014	426-433	21	3.27	68.8	0.156

Over the course of the growing season, the average biomass of stems increased, with a peak of 0.177 g (dry weight) per stem occurring at the beginning of July (Table 15). Typically, Eurasian watermilfoil shows a peak in biomass prior to a period of autofragmentation, where stem segments near the top of the plant form roots and break away from the parent plant (Smith & Barko, 1990). In this case, a decrease in biomass was observed following the maximum (Figure 23), consistent with plant segments breaking away from the parent plant. Based on this observation, the autofragmentation period in the model was set to start on July 1st. Flowering milfoil plants were not observed in Christina Lake during the study. Plants build biomass after losses from

autofragmentation until mid to late August, when natural senescence is initiated (Reeves, et al. 2008).

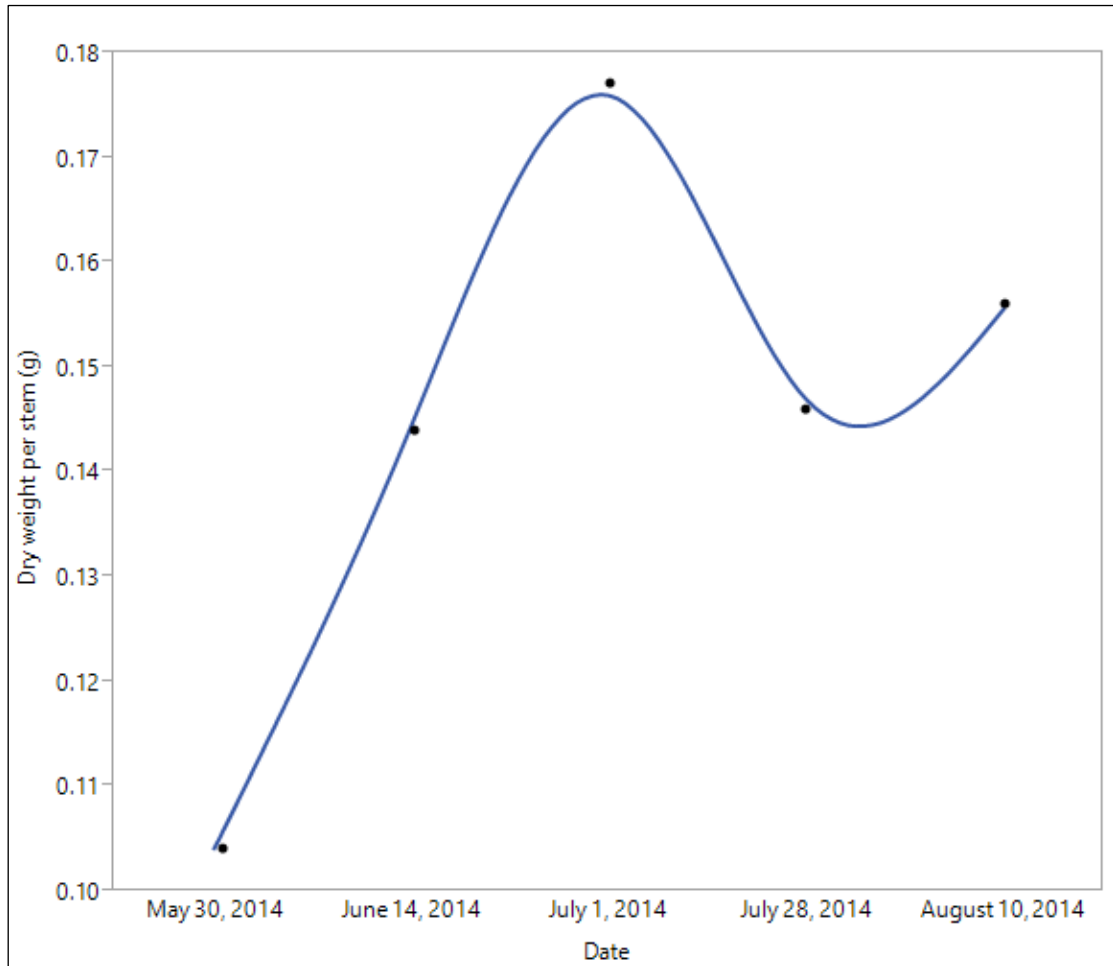

Figure 23. Average biomass (dry weight per stem) of Eurasian watermilfoil plants in Christina Lake, B.C. from May to August 2014

The stem length (Table 16) continually increased during the growing season, from an average of 26.0 to 68.8 cm.

Table 16. Average milfoil stem length over the course of the 2014 growing season in Christina Lake, BC

Date	n	Stem Length (cm)			
		Mean	Std Dev	Variance	Std Err
May-30	28	25.96	7.11	50.59	1.34
Jun-14	26	33.32	11.11	123.39	2.18
Jul-01	18	53.22	24.93	621.70	5.88
Jul-28	12	60.58	24.92	621.05	7.19
Aug-10	21	68.81	39.63	1570.86	8.65

3.2.3 Current milfoil weevil population in Christina Lake

A number of methods were employed to gain insight on the presence of the milfoil weevil in Christina Lake. Eurasian watermilfoil that was removed by SCUBA divers was taken and inspected for signs of insect herbivory and presence of milfoil weevil eggs, larvae and adults. Adhesive insect traps were employed to target adults migrating from their aquatic to overwintering terrestrial habitat and leaf litter/soil samples were collected to determine presence of overwintering adults. The information gained from these methods was used to set an initial population value for weevils in Christina Lake for the simulation model.

3.2.3.1 Inspection of Eurasian watermilfoil for insect herbivory and weevil presence

From May to August, plants were obtained from the Eurasian watermilfoil control sites shown on Figure 22. Approximately 5 kg (wet weight) of plants were obtained from the dive team on each occasion and placed in a Rubbermaid™ tote filled with water. A minimum of 100 Eurasian watermilfoil plants were visually assessed for signs of insect herbivory, presence of *E. lecontei* (all life stages), and overall vigor of the plant. Observations were made with the aid of a dissecting microscope. The leaves surrounding the meristem were examined for evidence of feeding and presence of eggs. The upper

portion of the stem was examined for larvae and evidence of burrowing. After the plants in the sample were processed, the water and remaining material in the tote was directed through a 200 micron sieve. The material was examined to determine if weevils were present in the sample.

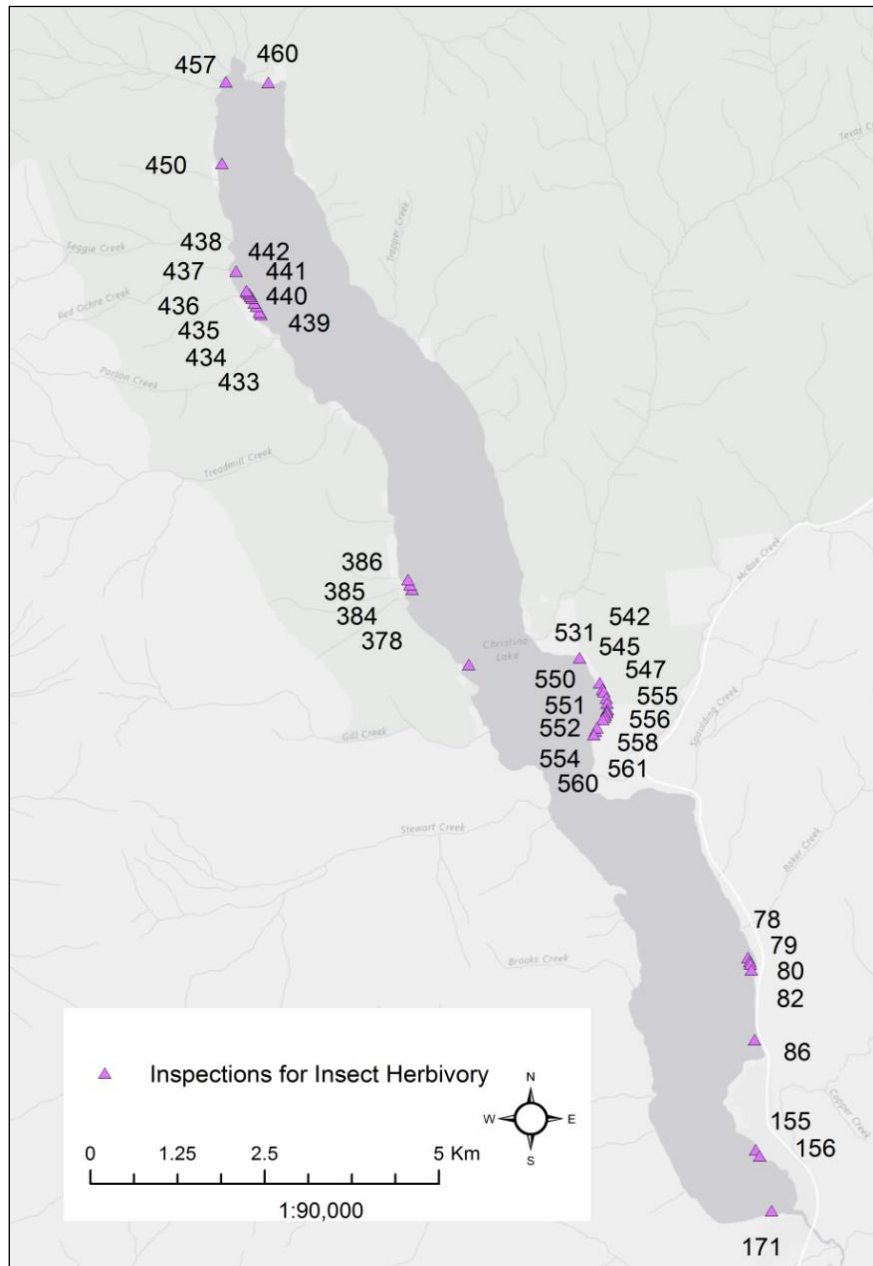

Figure 24. Locations of Eurasian watermilfoil plants that were inspected for evidence of invertebrate herbivore activity

Eurasian watermilfoil from two sites adjacent to Schulli's Resort showed impacts that could be attributed to weevil burrowing and feeding behaviour. Approximately 5% of the plants collected from Eurasian watermilfoil control sites 155 and 156 contained burrows outlined by blackish-brown areas in the upper portion of the stem. The stem

segments appeared to be hollow and flattened in some cases. Leaves found within the impacted sections were yellow in colour.

Although evidence suggests that weevils may be present in the area adjacent to Schulli’s Resort, weevils were not encountered during the Eurasian watermilfoil observations. Table 17 summarizes the date and locations that Eurasian watermilfoil was visually assessed for evidence of invertebrate herbivory.

Table 17. Observation of insect herbivory at Eurasian watermilfoil control sites on Christina Lake, BC

Date	Site No.	Observations
June 17, 2013	171	No evidence of insect herbivory
June 23, 2013	378, 384-386	No evidence of insect herbivory
July 11, 2013	155, 156	Possible larval damage in approximately 5% of plants- sample collected and preserved.
July 22, 2013	433-442	No evidence of insect herbivory
July 26, 2013	78-80, 82, 86	No evidence of insect herbivory
Aug 6, 2013	450	No evidence of insect herbivory
Aug 12, 2013	457	No evidence of insect herbivory
Aug 19, 2013	460	No evidence of insect herbivory
Aug 26, 2013	531, 540-542, 545, 547, 550-552, 554-556, 558, 560, 561	No evidence of insect herbivory

3.2.3.2 Emergence Trap

Adult weevils are capable of living in a non-aquatic environment, evident by their spring and fall migrations to shoreline where they overwinter in the leaf litter and surface soil (Newman, Ragsdale, Milles and Oien, 2001). An emergence trap was constructed that

would allow adult weevils to crawl from a sample of Eurasian watermilfoil into a collection jar.

The emergence trap was assembled using a 72 litre clear plastic Sterilite™ tote as the base. A frame was built from small diameter wooden dowel, in the shape of a pyramid so that it fit securely over the opening of the tote. Fine mesh screen (62 squares cm⁻¹) was placed over the wooden frame and secured. The small end at the top was fitted with an inverted jar to act as a collection container. Small twigs were placed inside the tote, extending up toward the top of the trap to aid any crawling insects emerging from the bottom of the tote.

Eurasian watermilfoil was obtained from the dive team and a sample of 5 kg (wet weight) was placed in the water-filled tote. An air bubbler was placed in the water to provide circulation in the tank. The trap was placed in a shaded outdoor location and left for one week, where the collection jar and mesh were periodically checked for insects. At the end of one week, contents of the jar were examined to determine the presence of the Eurasian watermilfoil weevil.

Eurasian watermilfoil from the Troy Creek Eurasian watermilfoil control site (no. 457) was added to the trap on August 12, 2013. After one week, there were no observed weevils in the collection jar or other areas of the trap. On August 19, 2013, after discarding Eurasian watermilfoil from the first trial, a second quantity from sites 459-461 was added to the trap. After a week, the contents of the collection jar and other areas of the trap did not contain the Eurasian watermilfoil weevil.

3.2.3.3 Terrestrial traps

Adult weevils develop flight muscles in the fall prior to migrating to the shoreline to overwinter in the leaf litter and soil adjacent to milfoil beds (Newman et al., 2001). Milfoil weevils are not known to overwinter on sandy beaches or altered shorelines. The highest numbers of overwintering weevils are found in natural areas close to shore and the population decreases relative to distance from the shoreline (Newman et al., 2001). Newman et al. (2001) used yellow adhesive insect traps as part of their assessment of the overwintering weevil population on the shoreline of Lake Minnetonka. This method was employed at Christina Lake in an attempt to intercept weevils migrating from the Eurasian watermilfoil beds to the shoreline in the fall.

When selecting the site for the placement of adhesive traps, the following points were taken into consideration: 1) Proximity to Eurasian watermilfoil beds, 2) availability of natural habitat, and 3) accessibility. The south portion of Christina Lake has a concentration of “high” Eurasian watermilfoil infestation levels, so focus was initially on this area. A large community nature park is situated on the eastern shore of the lake, and provides undisturbed grassland and forested habitat. Aside from the two public beaches at the south end of the lake, the nature park is the only non-private parcel of land bordering the lake in this area and allows unrestricted access.

Yellow, 14 x 18 cm adhesive insect traps that were double-sided and waterproof were used. The installation method allowed for trap placement close to the ground as milfoil weevils are not known to possess strong flight abilities (Newman et al., 2001). One end of a small-diameter wooden stake was placed in the soil and the trap was hung vertically from the other end so that the top was 30 cm above the ground surface. Fifteen traps, labeled 1 through 15 were set on September 22, 2013 within 3 m of the shore from

the start of Christina Creek to the north boundary of the nature park at Sutherland Creek.

Figure 25 shows the trap placement. For monitoring purposes, an approximately 80 additional traps were placed throughout the adjacent nature park, at varying distances from the lake shore.

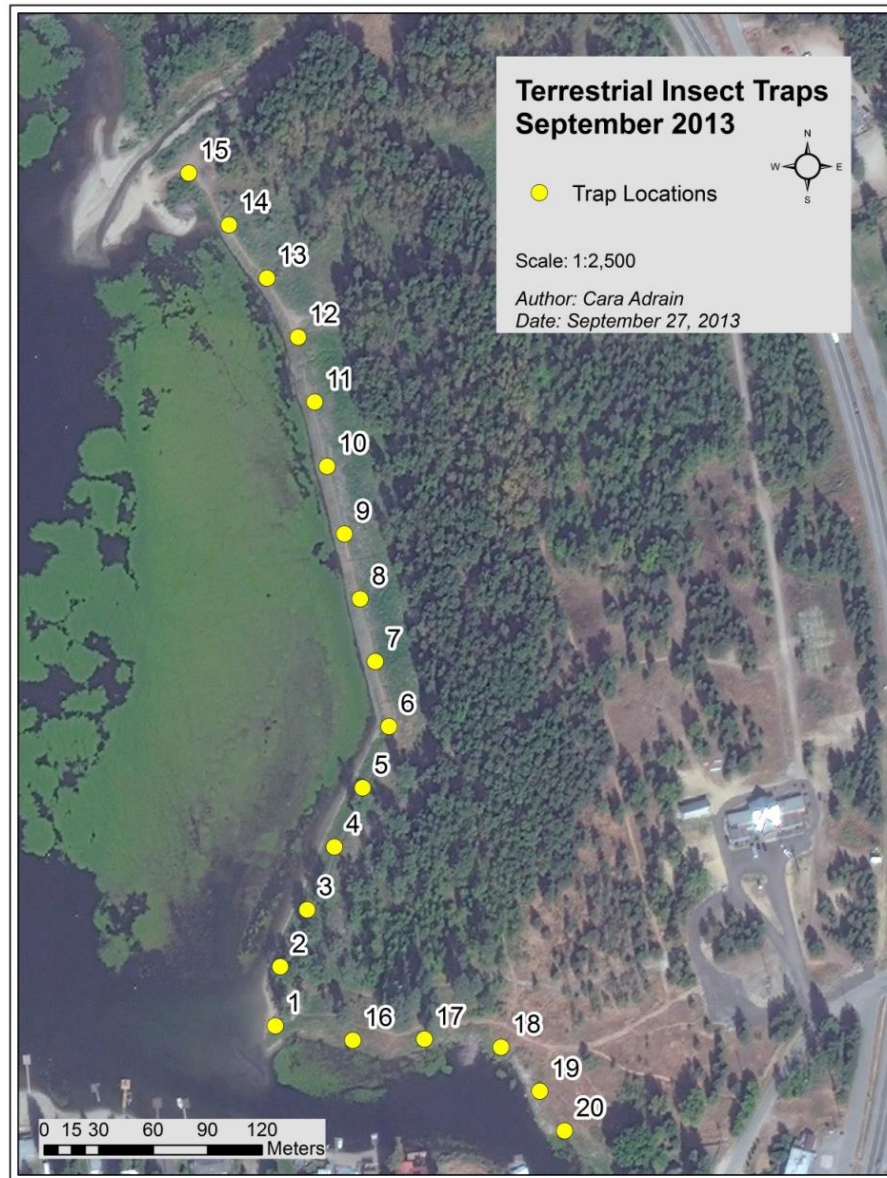

Figure 25. Adhesive insect trap locations, southeast shoreline of Christina Lake, B.C.

On September 29, 2013 the first set of traps was collected and new adhesive traps were left in place. The second set remained in-situ for a week before they were collected, and traps were labeled 1a through 15a.

In the laboratory, a dissecting microscope was used to evaluate the traps for presence of the weevil, *E. lecontei*. Non-weevil insects were identified to Order and in some cases Family.

With the exception of one trap, all those placed along the shoreline of the nature park were recovered. After a detailed review of the traps in the laboratory, no milfoil weevils were found. A majority of the insects were classified as flies (*Diptera*), parasitoid wasps (*Hymenoptera: Braconidae*) and aphids (*Hemiptera: Aphididae*). An estimate of the number of captured insects per card was reported and can be found in Appendix B.

3.2.3.4 Leaf litter and soil samples

Samples of the upper layers of leaf litter and soil were collected from the nature park located at the southeast corner of Christina Lake to monitor for the presence of overwintering adult weevils. This location was thought to provide the most suitable overwintering habitat for weevils at the south end of the lake. On November 8, 2013, seven samples were collected from within 3 m of shoreline (Figure 25). Sample sites were above the normal winter water level, in areas with leaf litter covering the soil surface. Areas of obvious disturbance were avoided. For each sample, leaf litter and soil from an area of 0.20 x 0.20 m and a depth of 0.15 m was placed in a plastic bag. Samples were placed in a freezer for storage. Samples were removed from the freezer and allowed to thaw at room temperature in the laboratory. The sample bags were emptied onto white trays and the contents were carefully sorted by hand once they were thawed. Invertebrates

were picked from the sample and identified with the aid of a dissecting microscope. After thoroughly sorting through the samples, no adult milfoil weevils were found.



Figure 26. Location of leaf litter/soil samples collected from the shoreline of Christina Lake, B.C. on November 8, 2013

3.2.4 Surface water temperature

The major driver of both weevil development and Eurasian watermilfoil growth is temperature (Smith and Barko 1990; Mazzei et al. 1999). Temperature data were

collected from the surface water at the south end of Christina Lake using HOBO™ temperature loggers.

Two HOBO™ pendant temperature loggers were placed in the littoral zone, in the area adjacent to the nature park. Loggers were attached to sinking nylon cord at 0.75 m below the water surface. A float was attached to the top of the cord and clearly marked with contact information. The length of the cord was designed to allow for fluctuating water levels, and the bottom was securely attached to a weight which rested on the bottom of the lake. A cinder block was used for one weight and a segment of coated I-beam was used for the other. Loggers were placed in water approximately 2 m deep. Both loggers were set to record temperature every hour. The first readings were disregarded to ensure that data that may have been recorded between logger deployment and placement in the field were not used in analysis. This also allowed the logger temperature to equilibrate with the environment in which it was placed. Loggers were deployed in the lake on April 13, 2014. Data were downloaded on July 22, 2014 and loggers were re-deployed. One of the temperature loggers went missing, so only one data set was available for an entire year.

3.2.5 Water depth

Eurasian watermilfoil growth is restricted to the littoral zone. A bathymetric map (British Columbia Fish and Game Branch, 1952) of Christina Lake was digitized and uploaded to ArcGIS (Figure 26). A triangular irregular network (TIN) was created and depth contours were created at 1 m intervals. A layer representing the Eurasian watermilfoil growth area (depth 1.0 to 4.0 m) was created to define the area where the concentration of Eurasian watermilfoil growth is expected to be highest. At each Eurasian

watermilfoil control point, the growth layer was divided at the adjacent property boundaries of lakefront residences unless otherwise described by the RDKB control program. This allowed for an area to be associated with each Eurasian watermilfoil control point.

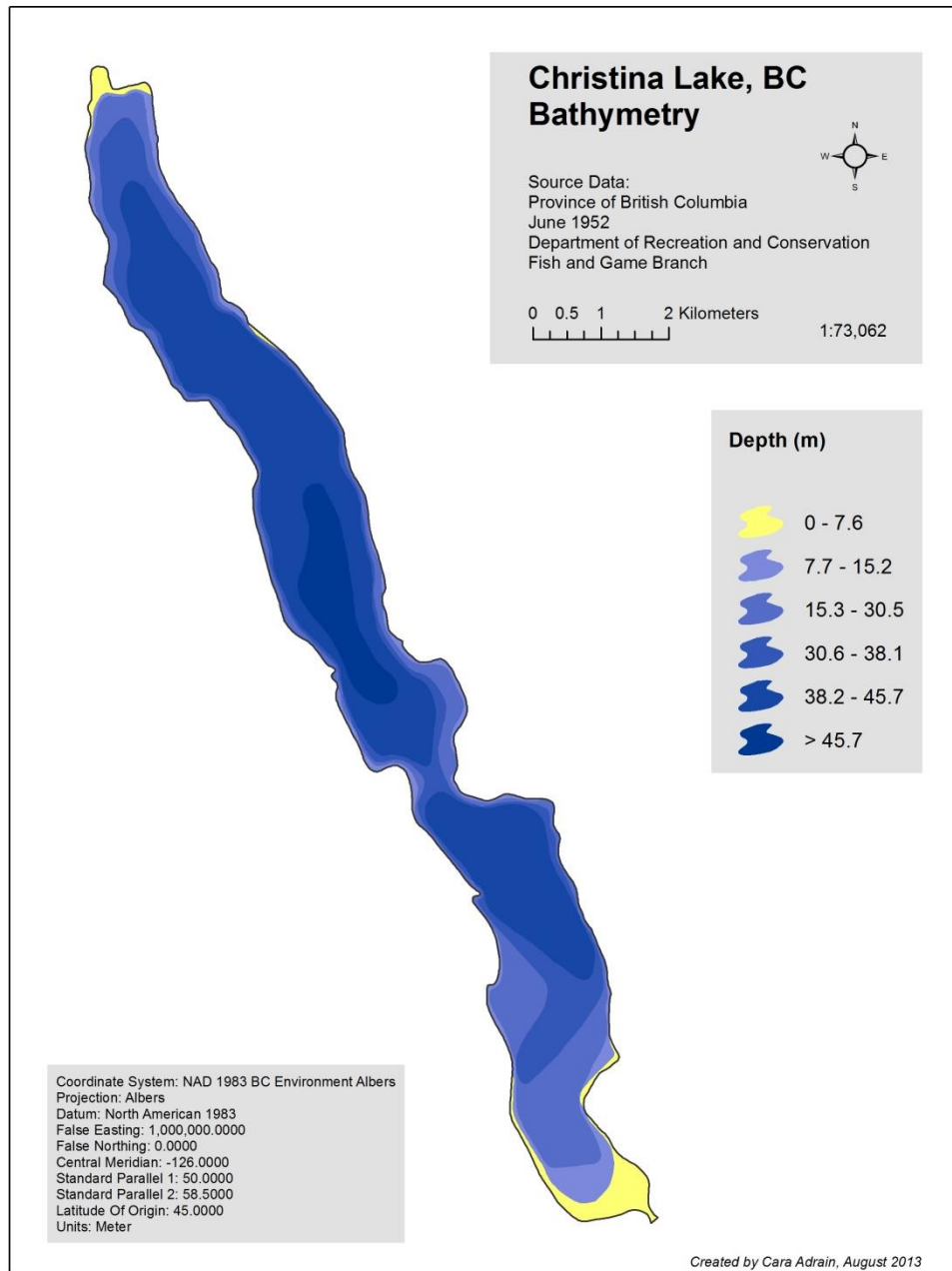

Figure 27. Bathymetric map of Christina Lake, B.C., adapted from the Province of British Columbia, 1952

3.2.6 Solar radiation

The mean daily global insolation values (kWh/m²) for Christina Lake are published by Natural Resources Canada (2014). Mean monthly values are based on the 20 years of data (Table 18).

Table 18. Mean daily global insolation (NRC 2014) for Christina Lake, B.C.

Month	Mean daily global irradiance (kWhm⁻²), horizontal surface
May	4.8
June	5.7
July	6.3
August	6.7
September	5.7
October	4.1
November	2.5

3.3 Conclusion

In Chapter 1, the review of research and scientific literature provided evidence that the milfoil weevil is the best option for future biological control of Eurasian watermilfoil in Christina Lake. Compared to the other potential biocontrol agents, the weevil has successfully been mass propagated in aquaria. The milfoil weevil is native to North America and it is a milfoil specialist and has shown negligible direct impact on non-*Myriophyllum* plant species. And, most importantly, in experimental trials and some biological control programs, the milfoil weevil has been shown to reduce milfoil biomass. Not all biological control programs using the milfoil weevil were successful at reducing

milfoil biomass to meet control objectives, which highlights the importance of further exploring the characteristics of the potential control site and the relationship between the milfoil and the milfoil weevil using site-specific variables.

Weevil augmentation programs have shown varying success at reducing Eurasian watermilfoil biomass in areas of North America. The simulation model developed specifically for Christina Lake can help to gain insight on the potential success of a future weevil augmentation program. From the output of the simulation model, we can see that success of a weevil augmentation program will likely not be limited by the temperature, irradiance and milfoil characteristics of Christina Lake. Even at the highest milfoil density sites in Christina Lake (approximately 3.5 stems per m²), based on the model output, 1 adult weevil per m² is expected to provide total milfoil control over the course of the growing season.

It is important to note that the model was designed to simulate the biomass response in an area of 1 m². By expanding the spatial scale of the model, a more accurate representation of biomass response can be expected. Factors including weevil distribution in the milfoil beds and milfoil biomass distribution through autofragmentation (currently modeled as a loss when the leaf segment leaves the 1 m² area of the current simulation model) are expected to have a significant effect on the milfoil biomass of the system.

Using the model output to visualize the response of the system to different augmentation levels can help to reduce the chances of project failure and help with resource allocations and budgeting. For example, the model shows that a relatively low weevil augmentation rate may provide the desired level of control, reducing expenditures for weevil stock. An interesting observation was made when working with the simulation model. Increasing the number of adult weevils added to the system did not always

translate into increased larvae numbers. The population of larvae is limited by meristem availability and in sites with low plant density such as Christina Lake, available meristems become occupied by weevil eggs and larva at a relatively rapid rate. Adding more adult weevils to the system beyond this threshold value produced negligible increases in larvae.

With limited funding to allocate towards the control of invasive species, insight such as the potential results that may be expected from a control program, can aid decision makers in determining which programs to fund, and can provide a more accurate estimate of funds required for successful control. In this way, the simulation model can be used as a tool for decision makers not only for Christina Lake, but for lakes in other areas. By modifying the input parameters to reflect site conditions, the model could be applied to other lakes with Eurasian watermilfoil infestations, for example, lakes in the Okanagan region of British Columbia.

There are a number of areas the model could be advanced with future work. Refinement of the weevil population model by incorporating a distribution function instead of a linear trend for weevil development rate (i.e. Lactin et al., 1995) would provide a more accurate representation of population dynamics. As discussed earlier, spatial scale is an important factor to consider when applying the results of the model to the entire lake. The model was designed to simulate biomass accumulation over 1 m^{-2} base area. In this square metre, larger-scale interactions are not considered, for example, edge effects, clumped milfoil distribution, and the transport of biomass to other areas through the aut fragmentation process (Miller et al., 2011).

Milfoil biomass data collected from Christina Lake was used for the development of the model and was therefore unsuitable for performing statistical tests of the model.

Future milfoil biomass sampling in Christina Lake would allow for further validation and refinement of the model.

More research is needed to identify factors that influence the success of weevils at controlling milfoil biomass. Potential factors that have been reported include predation by fish, competition between invertebrate herbivores, pathogens or parasites that impact the weevil and physical and chemical characteristics of the waterbody. Also, improvement of estimates that were made for some parameter values, for example, the base growth rate for milfoil would be valuable. Literature values have not been found for milfoil growth rates from Western Canada; much of the research has been geographically focused in Northeastern USA and Eastern Canada, in waterbodies that are generally eutrophic and support dense milfoil growth. Perhaps through sampling and field tests in Christina Lake, a relationship between nutrient and inorganic carbon availability and growth rate could be established.

REFERENCES

- Alwin, T. & Cheruvilil, K. (2009). *Biological control of Eurasian watermilfoil: A review of the native watermilfoil weevil*. Michigan State University. Extension Bulletin, WQ-61.
- Aquatic Resources Ltd. (2000). Christina Lake fish and fish habitat inventory: Results of October 1999 lake survey and August 1999 tributary surveys. Prepared for the Christina Lake Stewardship Society.
- Adams, M.S. & McCracken, M.D. (1974). Seasonal production of the *Myriophyllum* component of Lake Wingra, Wisconsin. *Journal of Ecology*, 62, 457–467.
- Borrowman, K. (2012). Distribution of two biotypes and a hybrid of Eurasian watermilfoil and their relationship with the milfoil weevil in Central Ontario. Master of Science Thesis. Trent University.
- Buckingham, G.R. & Ross, B.M. (1981). Notes on the biology and host specificity of *Acentria nivea* (= *Acentropus niveus*). *Journal of Aquatic Plant Management*, 19, 32–36.
- Burlingame, M. (2004). *Round Lake, Whitley County, Fish Management Report 2002*. Indiana Department of Natural Resources. Indianapolis, IN. Retrieved from <http://www.in.gov/dnr/fishwild/files/round02.pdf>
- Capers, R.S., Selsky, R., Bugbee G.J. & White, J.C. (2009). Species richness of both native and invasive aquatic plants influenced by environmental conditions and human activity. *American Journal of Botany*, 87, 306–314.
- Carigan, R. & Kalff, J. (1980). Phosphorus sources for aquatic weeds: Water or sediments? *Science*, 207, 987–989.
- Carpenter, S.R. (1980). The decline of *Myriophyllum spicatum* in a eutrophic Wisconsin lake. *Canadian Journal of Botany*, 58, 527–535.
- Caswell, D. (2010). *Eurasian milfoil control 2010. Christina Lake Eurasian milfoil control program report*. Regional District of Kootenay Boundary.
- Cavanagh, N. Nordin, R. & Bryan, J. (1994). *Christina Lake water quality assessment and objectives*. Water Quality Branch, Environmental Protection Department, Ministry of Environment, Lands and Parks, Province of British Columbia. Retrieved from <http://www.env.gov.bc.ca/wat/wq/objectives/christina/Christinatech.pdf>
- Chafin, L.G. (2010). *Information Bulletin, Lax Watermilfoil, Myriophyllum laxum*. Georgia Dept. of Natural Resources, Wildlife Management Division.

- City of Pittsfield. (2009). *Eurasian watermilfoil re-growth control project at Onota Lake*. Retrieved from <http://www.onotalake.com/docs/1237926148.pdf>
- Combs, W.S. (1977). *The measurement and prediction of irradiances available for photosynthesis by phytoplankton in lakes*. Ph.D. Thesis, Department of Civil Engineering, University of Minnesota.
- Confrancesco A. & Crosson, H. (1999). *Euhrychiopsis lecontei* (Dietz) *as a potential biocontrol agent of Eurasian watermilfoil* (*Myriophyllum spicatum* L.). Technical Report A-99-3, US Army Corps of Engineers.
- COSEWIC. (2003). *COSEWIC assessment and status report on the sockeye salmon* *Oncorhynchus nerka* (*Cultus* population) *in Canada*. Committee on the Status of Endangered Wildlife in Canada. Ottawa.
- Couch, R. & Nelson, E. (1986). *Myriophyllum spicatum* in North America. Proc. 1st International Symposium on watermilfoil (*Myriophyllum spicatum*) and related *Haloragaceae* species. *Aquatic Plant Management Society*, 8–18.
- Creed, R.P., Sheldon, S.P. & Cheek, D.M. (1992). The effect of herbivore feeding in the buoyancy of Eurasian watermilfoil. *Journal of Aquatic Plant Management*, 30, 75–76.
- Creed, R.P. & Sheldon, S.P. (1993). The effect of feeding by a North American weevil, *Euhrychiopsis lecontei*, on Eurasian watermilfoil (*Myriophyllum spicatum*). *Aquatic Botany*, 45, 245–256.
- Creed, R.P. & Sheldon, S.P. (1994a). The effect of two herbivorous insect larvae on Eurasian watermilfoil. *Journal of Aquatic Plant Management*, 32, 21–26.
- Creed, R.P. & Sheldon, S.P. (1994b). Aquatic weevils (Coleoptera: Curculionidae) associated with northern watermilfoil (*Myriophyllum sibiricum*) in Alberta. *Entomological News*, 105, 98–102.
- Creed, R.P. & Sheldon S.P. (1995). Weevils and watermilfoil: Did a North American herbivore cause the decline of an exotic plant? *Ecological Applications*, 5, 1113–1121.
- Creed, R.P. (1998). A biogeographic perspective on Eurasian watermilfoil declines: Additional evidence for the role of herbivorous weevils in promoting declines? *Journal of Aquatic Plant Management*, 36, 16–22.
- Cultus Sockeye Recovery Team (2005). *Conservation strategy for sockeye salmon* (*Oncorhynchus nerka*) *Cultus Lake population, in British Columbia*. Recovery of Nationally Endangered Wildlife (RENEW). Ottawa, Ontario, 48 pp.

- Cushing, N.L. (n.d.) *Eurasian watermilfoil and biological control: Research and results*. EnviroScience Ltd. Retrieved from <http://lakesteward.ca/files/research/milfoil/enviroScience.PDF>
- Dale, A.R. & Haberstock, D.H. (1992). *1991 Christina Lake Eurasian Watermilfoil Control Program*. Water Management Division Report No. 3659. B. C. Ministry of Environment, Lands and Parks.
- DeBach, P., & Rosen, D. (Eds.). (1991). *Biological control by natural enemies*. Cambridge University Press.
- EDDMapS. (2015). *Early Detection & Distribution Mapping System*. The University of Georgia - Center for Invasive Species and Ecosystem Health. Retrieved from <http://www.eddmaps.org/>
- Eiswerth, M.E., Donaldson, S.G.& Johnson, W. (2000). Potential Environmental Impacts and Economic Damages of Eurasian Watermilfoil (*Myriophyllum spicatum*) in Western Nevada and Northeastern California. *Weed Technology*, 14, 511–518.
- Ellis, J.R., Wilkins, S.P. & Bryan, J.E. (1991). *Assessment of Christina Lake water quality data 1972-1990*. B.C. Environment, Environmental Protection.
- Environment Canada. 2010. *Invasive Alien Species Partnership Program: 2005–2010 Report*. Retrieved from <https://www.ec.gc.ca/nature/default.asp?lang=En&n=B008265C-1>
- EnviroScience Inc. (n.d.). *Middfoil project description: Lake St. Helen, MI*. Retrieved from <http://web.archive.org/web/20030701131746/www.enviroscienceinc.com/cgi-bin/displayContent.pl?type=section&id=279>
- EnviroScience Inc. (2012). *2012 Progress report of the Milfoil Solution® program in Round Lake - Prepared for Rollin Township, Michigan*. Retrieved from <http://www.twp.rollin.mi.us/pdf/RL.Enviro.Report.8.24.12.pdf>
- EnviroScience Inc. (2013a). *2013 Milfoil Solution® progress report at Loch Garry*. Retrieved from http://www.northglengarry.ca/en/townhall/resources/Report_LochGarry_2013.pdf
- EnviroScience Inc. (2013b). *2013 Milfoil Solution® progress report at the City of Greater Sudbury*. Retrieved from <http://agendasonline.greatersudbury.ca/index.cfm?pg=feed&action=file&agenda=report&itemid=2&id=784>
- EnviroScience Inc. (2014). *2013 Milfoil Solution® progress report at Big Cedar Lake: Prepared for the Big Cedar Lake Stewardship Association*. Retrieved from <http://bclsa.ca/documents/2014/Enviroscience-Report-Big-Cedar-2013.pdf>

- Evans, C. (2007). Eurasian watermilfoil (*Myriophyllum spicatum*). University of Illinois, Centre for Invasive Species and Ecosystem Health. Retrieved from: www.invasive.org
- Geosyntec Consultants. (2012). *Lake Mansfield 2012 aquatic vegetation survey*. Retrieved from http://www.lakemansfield.org/pdf_pages/aquatic_veg_survey_2012.pdf
- Government of British Columbia. (1952). *Christina Lake bathymetric survey (map)*. Fish and Game Branch, Department of Recreation and Conservation.
- Government of Canada. (2008). *Invasive alien plants in Canada – summary report*. Canadian Food and Inspection Agency. Retrieved from <http://epe.lac-bac.gc.ca/100/206/301/cfia-acia/2011-09-21/www.inspection.gc.ca/english/plaveg/invENV/techrpt/summrese.shtml#a1>
- Greater Sudbury Watershed Alliance.(2014). *GSWA response to the EnviroScience 2013 milfoil report to the City of Greater Sudbury*. Retrieved from http://gswa.ca/uploads/3/4/5/2/3452924/gswa_response_to_milfoil_project_2013_report.pdf
- Greater Sudbury. (2014). *Biological control of Eurasian water-milfoil using milfoil weevils – project results*. Presentation to City Council, July 8, 2014. Retrieved from <http://agendasonline.greatersudbury.ca/index.cfm?pg=feed&action=file&agenda=report&itemid=2&id=784>
- Haberstock, D. (2004). *Control of Eurasian watermilfoil, Christina Lake 2004*. Christina Lake Milfoil Control Program, Regional District of Kootenay Boundary.
- Haberstock, D. (2005). *Control of Eurasian watermilfoil, Christina Lake 2005*. Christina Lake Milfoil Control Program, Regional District of Kootenay Boundary.
- Haberstock, D. (2006). *Control of Eurasian watermilfoil, Christina Lake 2006*. Christina Lake Milfoil Control Program, Regional District of Kootenay Boundary.
- Hanson, T., Eliopoulos, C. & Walker, A. (1995). Field collection, laboratory rearing and in-lake introductions of the herbivorous aquatic weevil, *Euhrychiopsis lecontei*, in Vermont: Year 2. Vermont Department of Environmental Conservation, Waterbury, VT. 41 pp
- Herb, W. & Stefan, H. (2003). Integral growth of submersed macrophytes in varying light regimes. *Ecological Modeling*.168, 77–100.

- Herb, W. & Stefan, H. (2006). Seasonal growth of submersed macrophytes in lakes: The effects of biomass density and light competition. *Ecological Modelling*, 193, 560–574.
- Hilovsky, M. (2006). *Middfoil goes International!* EnviroScience, Weevil Gazette. Retrieved from <http://hickslake.org/Files/Weevil%20Gazette.pdf>
- Huber, J.T. & Mason, P.G. (eds). (2002). *Biological Control Programmes in Canada 1981-2000*. CABI Publishing, Wallingford, Oxon, UK, 583.
- Invasive Alien Plant Program (IAPP). (2012). *Myriophyllum spicatum* (Eurasian watermilfoil). In: Klinkenberg, B. (Ed.). (2012). E-Flora BC: Electronic Atlas of the Flora of British Columbia [eflora.bc.ca]. Lab for Advanced Spatial Analysis, Department of Geography, University of British Columbia, Vancouver.
- Iowa State University (2016). *Euhrychiopsis lecontei*, Fairbanks, Alaska, USA. Department of Entomology Bug Guide. Retrieved from www.bugguide.net.
- Jester, L.L., Bozek, M.A., Helsel, D.R. & Sheldon, S.P. (2000). *Euhrychiopsis lecontei* distribution, abundance and experimental augmentations for Eurasian watermilfoil control in Wisconsin Lakes. *Journal of Aquatic Plant Management*, 38, 88–97.
- Johnson, R.L. & Blossey, B. (2002). *Eurasian Watermilfoil*. In: Van Driesche, R. (2002). *Biological Control of Invasive Plants in the Eastern United States*. USDA Forest Service
- Kangasniemi, B.J., Speier, H. & Newroth, P. (1993). *Review of Eurasian watermilfoil biocontrol by the milfoil midge*. Proceedings of the 27th Annual Meeting on the Aquatic Plant Control Research Program. Misc. Paper A-93-2, Waterways Experimental Station, Vicksburg, MS.
- Kirk, J.T.O. (2003). The vertical attenuation of irradiance as a function of the optical properties of water. *Limnological Oceanography*, 48, 9–17.
- Lavoie, M. (2010). *L'utilisation du çharançon pour le contrôle biologique du muriophylle à épis*. Master of Science Thesis. Université du Québec à Montréal
- Lillie, R.A. (1996). A quantitative survey of the floating-leafed and submersed macrophytes of Fish Lake, Dane County, Wisconsin. *Transactions of the Wisconsin Academy of Sciences, Arts and Letters*, 84, 111–125.
- Lillie, R.A. (2000). Temporal and spatial changes in milfoil distribution and biomass associated with weevils in Fish Lake, WI. *Journal of Aquatic Plant Management*, 30, 98–104.

- Lillie, R.A. & Helsel, D. (1997). *A native weevil attacks Eurasian watermilfoil. Research management findings*. Bureau of Research, Wisconsin Department of Natural Resources.
- Loch Garry Lake Association. (2013). *Three years of weevils!* Retrieved from <http://www.lochgarrylakeassociation.ca/>
- Lovell, G. (2009). Eurasian watermilfoil (*Myriophyllum spicatum*). Alabama Department of Conservation and Natural Resources. Retrieved from www.invasive.org
- Lovell, S.J. & Stone, S.F. (2005). *The economics impacts of aquatic invasive species: A review of the literature*. U.S. Environmental Protection Agency. National Center for Environmental Economics. Working Paper #05-02.
- Lund, C. & Caswell, D. (2009). The North American *Myriophyllum spicatum* (Eurasian milfoil) invasion: is biological control a viable solution for the lakes of the B.C. Interior? UBCO and the Regional District of Kootenay Boundary, Christina Lake Eurasian milfoil control program.
- MacRae, I.V., Winchester, N.N. & Ring, R.A. (1990). Feeding activity and host preference of the milfoil midge, *Cricotopus myriophyllii* Oliver (Diptera: Chrionomidae). *Journal of Aquatic Plant Management*, 28, 89–92.
- May, G. (2010). Attack of the killer weed: Weevil battles aggressive intruder choking Ontario waterways. Retrieved from <http://www.mynewwaterfronthome.com/weeds.aspx>
- Mazzei, K.C., Newman, R.M., Loos, A. & Ragsdale, D.W. (1999). Development rates of the native milfoil weevil, *Euhrychiopsis lecontei*, and damage to Eurasian watermilfoil at constant temperatures. *Biological Control*, 16, 149–143.
- McGregor, H. (2007). *Evaluation of the microbial community structure's ability to illustrate change in trophic status in Christina Lake*. M. Sc. Thesis. Royal Roads University, Sooke, B.C.
- Milfoil Solution, Inc. (2012). *2012 progress report of the Milfoil Solution ® program in Loch Garry*. Retrieved from http://static1.1.sqspcdn.com/static/f/1364366/21184972/1354755081790/Report_Loch+Garry_2012.pdf?token=nKSMIx7eYcu7rrtX2YQC%2BCn06fg%3D
- Miller, J.K., Roketenetz, L. & Garris, H. (2011). Modeling the interaction between the exotic invasive aquatic macrophyte *Myriophyllum spicatum* and the native biocontrol agent *Euhrychiopsis lecontei* to improve augmentation programs. *Biological Control*, 56, 934–945.

- Moody, M.L. & Les, D.H. (2002). Evidence of hybridity in invasive watermilfoil (*Myriophyllum*) populations. *Proceedings of the National Academy of Science USA*, 99, 14867–14871.
- Natural Resources Canada (NRC). (2014). *Photovoltaic potential and solar resources maps of Canada*. Retrieved from <http://pv.nrcan.gc.ca/index.php?n=2958&m=u&lang=e>
- Newman, R.M., Holmberg, K.L., Biesboer, D.D. & Penner, B. (1996). Effects of a potential biocontrol agent, *Euhrychiopsis lecontei*, on Eurasian watermilfoil in experimental tanks. *Aquatic Botany*, 53, 131–150.
- Newman, R.M., Borman, M.E. & Castro, S. W. (1997). Developmental performance of the weevil *Euhrychiopsis lecontei* on native and exotic watermilfoil host plants. *Journal of the North American Benthological Society*, 16(3), 627–634.
- Newman, R.M. & Biesboer, D.D. (2000). A decline of Eurasian watermilfoil in Minnesota associated with the milfoil weevil, *Euhrychiopsis lecontei*. *Journal of Aquatic Plant Management*, 38, 105–111.
- Newman, R.M., Ragsdale, D.W., Milles, A. & Oien, G. (2001). Overwinter habitat and the relationship of overwinter to in-like densities of the Eurasian watermilfoil weevil, *Euhrychiopsis lecontei*, a Eurasian watermilfoil biological control agent. *Journal of Aquatic Plant Management*, 39, 63–67.
- Newman, R.M. (2004). Invited review: Biological control of Eurasian watermilfoil by aquatic insects: basic insights from an applied problem. *Archiv Fur Hydrobiologie*, 159, 145–184.
- Newroth, P.R., & Maxnuk, M.D. (1993). Benefits of the British Columbia aquatic plant management program. *Journal of Aquatic Plant Management*, 31, 210–213.
- North Carolina Dept. of Agriculture & Consumer Services (NCAC). (2010). *Protected plant species list*. The North Carolina Plant Conservation Board.
- O'Brien, C.W. & Wibmer, G.J. (1982). Annotated checklist of the weevils (Curculionidae sensu lato) of North America, Central America, and the West Indies (Coleoptera: Curculionidae). *Memoirs of the American Entomological Institute*, 34, 1–3.
- Oden, J.D. & Tamayo, M. (2014). Incentivizing the public to support invasive species management: Eurasian watermilfoil reduces lakefront property values. *PLoS ONE*, 9(10).
- Okanagan Basin Water Board. (2009). *Management Plan for Eurasian Watermilfoil (Myriophyllum spicatum) in the Okanagan, British Columbia*. http://www.obwb.ca/fileadmin/docs/090512_ewm_management_plan.pdf

- Parsons, J.K., Marx, G.E. & Divens, M. (2011). A study of Eurasian watermilfoil, macroinvertebrates and fish in a Washington lake. *Journal of Aquatic Plant Management*, 49, 71–82.
- Pedersen, O., Colmer, T.D. & Sand-Jensen, K. (2013). Underwater photosynthesis of submerged plants – recent advances and methods. *Frontiers in Plant Science*, 4(140), 1–19.
- Province of B.C. (2012). *Tourism indicators: tourism sector sees modest growth in 2011*. B.C. Stats. Issue #12-01. Retrieved from <http://www.bcstats.gov.bc.ca/StatisticsBySubject/BusinessIndustry/Tourism.aspx>
- Reeves, J.L., Lorch, P.D., Kershner, M.W. & Hilovsky, M.A. (2008). Biological control of Eurasian watermilfoil by *Euhrychiopsis lecontei*: Assessing efficacy and timing of sampling. *Journal of Aquatic Plant Management*, 46, 144–149.
- Regional District of Kootenay Boundary (RDKB). (2012). *Plants removed from Eurasian watermilfoil control sites - dataset*. Unpublished data.
- Regional District of Kootenay Boundary (RDKB). (2013). *Plants removed from Eurasian watermilfoil control sites - dataset*. Unpublished data.
- Regional District of Kootenay Boundary (RDKB). (2014). *Plants removed from Eurasian watermilfoil control sites - dataset*. Unpublished data.
- Retzer, B. & Haberstock, D. (1989). *1988 Christina Lake Eurasian Watermilfoil Control Program*. Water Management Branch Report No. 3560. British Columbia Ministry of Environment.
- Retzer, B. & Haberstock, D. (1990). *The 1989 Christina Lake Eurasian Watermilfoil Control Program*. Water Management Branch Report No. 3595. British Columbia Ministry of Environment.
- Retzer, B. & Haberstock, D. (1991). *1990 Christina Lake Eurasian Watermilfoil Control Program*. Water Management Division Report No. 3626. B.C. Environment.
- Retzer, B. & Haberstock, D. (1993). *The 1992 Christina Lake Eurasian Watermilfoil Control Program*. Water Management Division Report No. 3684. B. C. Ministry of Environment, Lands and Parks. 33 pp.
- Riley, M.J. & Stefan, H.G. (1988). MINLAKE: A dynamic lake water quality simulation model. *Ecological Modeling*, 43, 155–182.
- Rockwell, H.W. (2003). *Summary of a Survey of the Literature on the Economic Impact of Aquatic Weeds*. AERF Report August 2003. Aquatic Ecosystem Restoration Foundation, Flint, MI.

- Roley, S.S. & Newman, R.M. (2006). Development performance of the milfoil weevil, *Euhrychiopsis lecontei* (Coleoptera: Curculionidae), on northern watermilfoil, Eurasian watermilfoil, and hybrid (northern x Eurasian) watermilfoil. *Environmental Entomology*, 35, 121–126.
- Scribalio, R.W. & Alix, M.S. (2003). *Final report on the weevil release study for Indiana lakes*. Department of Botany and Plant Pathology. Purdue University. West Lafayette, IN.
- Scugog Lake Stewards Inc. (2012). A proposal for improving Lake Scugog's ecological health. Retrieved from <http://scugoglakestewards.com/wp-content/uploads/2013/01/Report-to-Ontario-Waterways-2013-.pdf>
- Scugog Lake Stewards Inc. (2014). *Milfoil weevil project update (August 12, 2014)*. Retrieved from <http://scugoglakestewards.com/milfoil-weevil-project-donate/>
- Scugog Lake Stewards Inc. (2015). *Lake Scugog general information*. Retrieved from <http://scugoglakestewards.com/about-the-lake/general-information-about-lake-scugog/>
- Shearer, J.F. (2010). *Relationship between Eurasian watermilfoil phenology and endophyte presence*. APCRP Technical Notes Collection. ERDC/TN APCRP-BC-20. Vicksburg, MS: U.S. Army Engineer Research and Development Center.
- Sheldon, S.P. & Creed, R.P. (1995). Use of native insects as a biological control for an introduced weed. *Ecological Applications*, 5(4), 1122–1132.
- Sheldon S.P. & O'Bryan, L.M. (1996). Life history of the weevil *Euhrychiopsis lecontei*, a potential biological control agent of Eurasian watermilfoil. *Entomological News*, 107, 16–22.
- Sheldon, S.P. (1997). Investigations on the potential use of an aquatic weevil to control Eurasian watermilfoil. *Lake and Reservoir Management*, 13(1), 79–86.
- Smith, C.S. & Barko, J.W. (1990). Ecology of Eurasian watermilfoil. *Journal of Aquatic Plant Management*, 28, 55–64.
- Solarz, S.L. & Newman, R.M. (1996). Oviposition specificity and behavior of the watermilfoil specialist *Euhrychiopsis lecontei*. *Oecologia*, 106, 337–344
- Solarz, S.L. & Newman, R.M. (2001). Variation in hostplant preference and performance by the milfoil weevil, *Euhrychiopsis lecontei* Dietz, exposed to native and exotic watermilfoils. *Oecologia*, 126, 66–75.

- Stanley, R.A. & Naylor, A.W. (1972). Photosynthesis in Eurasian watermilfoil (*Myriophyllum spicatum*). *Plant Physiology*, 50, 149–151.
- Swain, L.G. (1987). *Second report on chemical sensitivity of B.C. lakes to acidic inputs*. Water Quality, Water Management Branch, Environment and Resource Division, Ministry of Environment, Lands and Parks. Retrieved from <http://www.env.gov.bc.ca/wat/wq/reference/acidrain/acidrain.html>
- Tamayo, M. & Grue, C. (2004). Development performance of the milfoil weevil (Coleoptera: Curculionidae) on watermilfoils in Washington State. *Population Ecology*, 33, 872–880.
- Titus, J., Goldstein, R.A., Adams, M.S., Mankin, J.B., O'Neill, R.V., Weiler, P.R., Shugart, H.H. & Booth, R.S. (1975). A Production Model for *Myriophyllum spicatum* L. *Ecology*, 56(5), 1129–1138.
- Titus, J.E. (1977). *The comparative physiological ecology of three submersed macrophytes*. PhD dissertation. University of Wisconsin, USA
- United States Dept. of Agriculture (USDA). (2015). *Myriophyllum laxum*, plant profile. Plants Database, National Resource Conservation Service. Retrieved from <http://plants.usda.gov/core/profile?symbol=MYLA2>
- United States Environmental Protection Agency (USEPA). (1997). *Use of aquatic weevils to control a nuisance weed in Lake Bomoseen, VT*. Watershed Protection: Clean Case Study. Retrieved from <http://water.epa.gov/type/lakes/bomoseen.cfm>
- University of Maryland Centre for Environmental Science (UMCES), (2016). Water clarity. Retrieved from http://teachoceanscience.net/modulepopup/fish_and_physics/water_clarity/
- University of Minnesota. (2015). *Additional Cricopus myriophyllii information*. Department of Fisheries, Wildlife and Conservation Biology. Retrieved from <http://fwcb.cfans.umn.edu/research/milfoil/milfoilbc/Cricotopusinfo.html>
- Unmuth, J.M.L., Lillie, R.A., Dreikosen, D.S. & Marshall, D.W. (2000). Influence of dense growth of Eurasian watermilfoil on lake water temperature and dissolved oxygen. *Journal of Freshwater Ecology*, 15(4), 497–503.
- Wallis, M. & Haberstock, D. (1988). *1987 Christina Lake Eurasian water milfoil Control Program*. Water Management Branch. British Columbia Ministry of Environment.
- Waterloo Region Record. (2011). *Eurasian watermilfoil shows harsh reality of invasive species*. Retrieved from <http://www.therecord.com/news-story/2584831-eurasian-watermilfoil-shows-harsh-reality-of-invasive-species/>

Wilcove, D.S, Rothstein, D., Dubow, J., Philips, A., & Losos, E. (1998). Quantifying threats to imperiled species in the United States. *BioScience*, 48, 607–615.

Zawacki, M. (2002). *Beetle Mania*. Inside Business Magazine. Retrieved from http://ibmag.com/QualityControl/Archive/Beetle_Mania_11216.aspx

Personal Communication

Stanley, A. (2012). Director, Environment. Regional District Kootenay Boundary.

APPENDICES

APPENDIX A

Annual M. spicatum plants harvested by SCUBA divers from 2012 to 2014, Christina Lake, British Columbia

Site	Site Name	2012 Total	2013 Total	2014 Total
1	Christina Lake Marina	1450	785	386
2	1st House South of Marina	5	3	80
3	2nd House South of Marina	17	6	30
4	Alpine Resort	8	2	0
5	Wasnea	0	10	0
6	1st House South of Wasnea	860	25	0
7	Thatcher	0	5	2
8	Sunflower Inn	0	2	0
9	1st House South of Sunflower Inn	0	3	0
10	2nd House South of Sunflower Inn	0	0	0
11	3rd House South of Sunflower Inn	0	0	0
12	4th House South of Sunflower Inn	0	0	0
13	5th House South of Sunflower Inn	0	3	5
14	6th House South of Sunflower Inn	4	1	1
15	7th House South of Sunflower Inn	0	2	1
16	8th House South of Sunflower Inn	8	4	1
17	English Bay Dive Tower	2	2	1
18	1st House South of Dive Tower	1	0	5
19	2nd House South of Dive Tower	0	0	2
20	3rd House South of Dive Tower	0	10	4
21	4th House South of Dive Tower	0	0	1
22	5th House South of Dive Tower	0	0	3
23	6th House South of Dive Tower	0	0	7
24	7th House South of Dive Tower	0	0	7
25	8th House South of Dive Tower	0	0	20
26	9th House South of Dive Tower	0	0	2
27	10th House South of Dive Tower	0	0	2
28	11th House South of Dive Tower	0	0	2
29	12th House South of Dive Tower	0	0	0
30	13th House South of Dive Tower	3	0	0
31	14th House South of Dive Tower	0	0	0
32	15th House South of Dive Tower	0	0	2
33	Big Ol' Brick House	0	0	0
34	1st House South of Brick House	0	0	4
35	2nd House South of Brick House	0	0	0
36	3rd House South of Brick House	0	0	6

Site	Site Name	2012 Total	2013 Total	2014 Total
37	4th House South of Brick House	0	0	0
38	5th House South of Brick House	0	0	0
39	6th House South of Brick House	2	0	2
40	7th House South of Brick House	3	0	0
41	8th House South of Brick House	1	0	4
42	9th House South of Brick House	0	0	5
43	10th House South of Brick House	0	0	2
44	11th House South of Brick House	1	0	2
45	12th House South of Brick House	0	0	1
46	13th House South of Brick House	0	0	0
47	14th House South of Brick House	0	0	0
48	15th House South of Brick House	0	0	0
49	16th House South of Brick House	3	0	0
50	17th House South of Brick House	0	0	0
51	18th House South of Brick House	0	0	0
52	19th House South of Brick House	2	0	0
53	20th House South of Brick House	6	0	1
54	21st House South of Brick House	0	0	1
55	22nd House South of Brick House	0	0	2
56	Simpson House	2	0	1
57	1st House South of Simpson House	0	0	1
58	2nd House South of Simpson House	0	2	0
59	3rd House South of Simpson House	0	1	5
60	4th House South of Simpson House	0	2	2
61	5th House South of Simpson House	11	5	11
62	6th House South of Simpson House	4	10	10
63	7th House South of Simpson House	10	20	7
64	8th House South of Simpson House	1440	2000	660
65	Beattie Residence	600	765	75
66	1st House South of Beattie	350	750	28
67	2nd House South of Beattie	20	18	8
68	3rd House South of Beattie	20	72	74
69	4th House South of Beattie	10	5	28
70	5th House South of Beattie	5	0	0
71	3rd House North of Baker Creek	0	6	4

Site	Site Name	2012 Total	2013 Total	2014 Total
72	2nd House North of Baker Creek	0	4	6
73	1st House North of Baker Creek	0	10	1
74	Baker Creek	700	25	14
75	1st House South of Baker Creek	500	80	28
76	2nd House South of Baker Creek	2000	60	1
77	3rd House South of Baker Creek	3000	110	0
78	4th House South of Baker Creek	300	100	3
79	Crain	120	20	5
80	1st House South of Crain	280	25	42
81	Nocente Residence	10	0	14
82	1st House South of Nocente	28	25	7
83	2575 Sunset Drive	40	5	16
84	Elkelston	33	5	13
85	1st House North of Little Colville	0	0	14
86	Highway Shoreline	150	130	41
87	1st House in Little Colville Bay	0	12	5
88	2nd House in Little Colville Bay	150	40	9
89	3rd House in Little Colville Bay	80	15	5
90	4th House in Little Colville Bay	50	10	0
91	5th House in Little Colville Bay	40	0	5
92	6th House in Little Colville Bay	40	0	2
93	7th House in Little Colville Bay	65	0	4
94	8th House in Little Colville Bay	10	0	1
95	McQuewan Residence	0	0	0
96	1st House South of McQuewan	0	0	4
97	2st House South of McQuewan	0	0	2
98	Brothers Residence	0	2	27
99	1st House South of Brothers	0	4	10
100	Glanville Residence	5	16	6
101	1st House South of Glanville	0	5	3
102	Teddy Bear Lodge	300	5	16
103	Henniger Residence	277	0	25
104	1st House South of Henniger	43	0	33
105	DeLuca Residence	21	23	15
106	1st House South of DeLuca	30	8	30
107	2nd House South of DeLuca	18	15	22
108	Palone Residence	50	20	5
109	1st House South of Palone	20	0	5
110	Ferraro Residence	40	110	3
111	1st House South of Ferraro	90	5	0
112	2nd House South of Ferraro	42	0	0
113	Pasqualotto	200	10	0

Site	Site Name	2012 Total	2013 Total	2014 Total
114	Gregory Residence	350	15	0
115	Jensen Residence	330	0	0
116	1st House South of Jensen	760	0	5
117	2nd House South of Jensen	95	60	11
118	3rd House South of Jensen	20	0	0
119	4th House South of Jensen	13	0	2
120	5th House South of Jensen	35	0	7
121	6th House South of Jensen	30	0	0
122	7th House South of Jensen	10	0	0
123	8th House South of Jensen	0	0	0
124	9th House South of Jensen	0	0	0
125	LaValley Point	1100	200	9
126	LaValley Point Public Beach	1000	85	4
127	1st House South of LaValley Point	310	50	1
128	2nd House South of LaValley Point	250	60	0
129	3rd House South of LaValley Point	22	26	0
130	4th House South of LaValley Point	10	32	5
131	5th House South of LaValley Point	10	15	15
132	1st House North of Kingsley's	0	50	0
133	Kingsley's Resort	3100	425	5
134	1st House South of Kingsley's Resort	2600	605	53
135	2nd House South of Kingsley's Resort	1200	405	501
136	Merry Residence	800	280	30
137	1st House South of Merry	950	82	15
138	Skand's Resort	5500	2961	413
139	1st House South of Skand's Resort	900	300	25
140	2nd House South of Skand's Resort	800	150	40
141	3rd House South of Skand's Resort	1700	1740	340
142	4th House South of Skand's Resort	4000	1369	420
143	5th House South of Skand's Resort	210	140	25
144	6th House South Of Skand's Resort	300	928	45
145	7th House South of Skand's	35	20	5

Site	Site Name	2012 Total	2013 Total	2014 Total
	Resort			
146	8th House South of Skand's Resort	25	26	10
147	9th House South of Skand's Resort	60	168	20
148	10th House South of Skand's Resort	75	50	5
149	11th House South of Skand's Resort	1200	1105	80
150	12th House South of Skand's Resort	1640	94	90
151	13th House South of Skand's Resort	610	260	315
152	14th House South of Skand's Resort	750	980	313
153	15th House South of Skand's Resort	2300	722	675
154	Public Beach North of Schulli's	4000	3558	383
155	Schulli's Resort - North	10000	20000	2380
156	Schulli's Resort - South	20000	40000	9000
157	Christina Sands - North	20000	40000	30000
158	Christina Sands - South	25000	40000	82000
159	Willow Beach Resort	25000	40000	15500
160	Lakeside Resort	25000	40000	22500
161	Jackman Residence	300	450	565
162	Pettapiece Residence	1000	510	190
163	1st House North of Pettapiece	845	1551	214
164	2nd House North of Pettapiece	3200	2560	195
165	3rd House North of Pettapiece	3500	1270	230
166	4th House North of Pettapiece	2700	920	205
167	5th House North of Pettapiece	1700	945	250
168	6th House North of Pettapiece	1875	1405	800
169	Butler Residence	4000	9200	3700
170	2nd House North of Butler	10000	13900	6800
171	Chilcot Residence	25000	45000	11290
172	Glanville's Old Residence	25000	45000	6700
173	McGilvary Residence	25000	45000	16000
174	Gillespie Residence	25000	45000	12550
175	1st House North of Gillespie	25000	45000	8550
176	2nd House North of Gillespie	25000	45000	9550
177	Christina Lake Public Beach	25000	45000	850
178	Stern Residence	25000	45000	4700
179	1st House North of Stern	25000	45000	7150

Site	Site Name	2012 Total	2013 Total	2014 Total
180	2nd House North of Stern	15000	20500	17600
181	Loon Haven	5000	5300	685
182	Stephanelli Residence	2000	3500	2250
183	1st House North of Stephanelli	2000	5500	380
184	2nd House North of Stephanelli	2000	5500	290
185	3rd House North of Stephanelli	2000	4800	175
186	4th House North of Stephanelli	2000	3620	1170
187	5th House North of Stephanelli	3000	6000	22980
188	6th House North of Stephanelli	3500	6000	6825
189	7th House North of Stephanelli	5000	11000	2430
190	Silver Birch Campground	6000	8500	7670
191	1st House North of Silver Birch	360	75	90
192	Ralph's House	450	80	106
193	1st House South of Archibald	120	70	269
194	Archibald Residence	575	310	60
195	1st Site North of Archibald	135	320	10
196	2st Site North of Archibald	NR	925	11
197	1st House South of Brewer	NR	360	30
198	Brewer Residence	NR	825	120
199	Muth Residence	NR	1000	505
200	Mauro Residence	NR	3850	600
201	1st House North of Mauro	NR	85	190
202	McPhee Residence	NR	275	16
203	1st House North of McPhee	NR	85	4
204	2st House North of McPhee	NR	70	2
205	Hamigamy Residence	NR	92	1
206	Public Access Dock	NR	240	8
207	1st House South of Freeman	NR	103	4
208	Freeman Residence	NR	18	0
209	1st House North of Freeman	NR	22	0
210	2nd House North of Freeman	NR	60	1
211	3rd House North of Freeman	NR	145	10
212	4th House North of Freeman	NR	363	50
213	5th House North of Freeman	NR	1127	84
214	Dunbar Residence	NR	1452	150
215	1st House North of Dunbar	NR	998	234
216	2nd House North of Dunbar	NR	1805	400
217	3rd House North of Dunbar	NR	630	20
218	4th House North of Dunbar	NR	300	0
219	5th House North of Dunbar	NR	50	0
220	6th House North of Dunbar	NR	28	0
221	7th House North of Dunbar	NR	43	15

Site	Site Name	2012 Total	2013 Total	2014 Total
222	8th House North of Dunbar	NR	105	5
223	2nd House South of Merritt	NR	60	5
224	1st House South of Merritt	NR	3	5
225	Merritt Residence	NR	40	0
226	1st House North of Merritt	NR	20	0
227	Cheveldave Residence	NR	8	5
228	Chevelais Residence	NR	0	1
229	Saskon Residence	NR	2	0
230	1st House South of Zappone	NR	1	6
231	Zappone Residence	NR	21	5
232	1st House North of Zappone	NR	95	0
233	LeRose Residence	NR	47	2
234	1st House North of LeRose	NR	17	10
235	Downey Residence	NR	20	30
236	1st House North of Downey	NR	1	5
237	1874 West Lake Drive	NR	2	10
238	1st House South of Lyon	NR	4	20
239	Lyon Residence	NR	30	18
240	1st House North of Lyon	NR	112	30
241	Norman Residence	NR	45	76
242	1st House North of Norman	NR	86	12
243	Rycroft Residence	NR	96	5
244	1st House North of Rycroft	NR	56	5
245	2nd House North of Rycroft	NR	47	0
246	Travery Residence	NR	10	13
247	1st House North of Travery	NR	5	5
248	Anderchuck Residence	NR	8	5
249	Tambellini Residence	NR	7	10
250	1st House North of Tambellini	NR	11	16
251	Phillip Residence	NR	10	11
252	1st Lot North of Phillip	NR	2	10
253	2nd House North of Phillip	NR	0	10
254	3rd Lot North of Phillip	NR	0	10
255	4th Lot North of Phillip	NR	0	14
256	5th Lot North of Phillip	NR	0	12
257	6th Lot North of Phillip	NR	0	19
258	7th Lot North of Phillip	NR	0	49
259	8th Lot North of Phillip	NR	0	38
260	Conklin Residence	NR	0	15
261	1st House North of Conklin	NR	0	25
262	Dupee Residence	NR	130	20
263	1st House North of Dupee	NR	0	0

Site	Site Name	2012 Total	2013 Total	2014 Total
264	Shoreline North of Dupee	NR	60	25
265	2nd House North of Dupee	NR	17	72
266	Campbell Residence	NR	10	17
267	Wolfe Residence	NR	20	14
268	Hansen Residence	NR	40	35
269	1st House North of Campbell	NR	5	27
270	2nd House North of Campbell	NR	0	16
271	3rd House North of Campbell	NR	0	9
272	4th House North of Campbell	NR	0	5
273	5th House North of Campbell	NR	5	10
274	Southern Section of Brewer Bay	NR	0	9
275	Middle Section of Brewer Bay	NR	96	7
276	Northern Section of Brewer Bay	NR	13	51
277	2nd House South of Bradley	NR	82	5
278	1st House South of Bradley	NR	48	30
279	Bradley Residence	NR	90	6
280	1st House North of Bradley	NR	34	8
281	Deldeke Residence	NR	320	120
282	1st House North of Deldeke	NR	135	50
283	2nd House North of Deldeke	NR	30	30
284	3rd Lot North of Deldeke	NR	33	45
285	Morrison Residence	NR	90	59
286	1st House North of Morrison	NR	80	70
287	2nd House North of Morrison	NR	1	3
288	3rd House North of Morrison	NR	0	5
289	4th House North of Morrison	NR	0	2
290	5th House North of Morrison	NR	0	5
291	Delich-Adair Residence	NR	0	5
292	1st House North of Delich-Adair	NR	14	8
293	Magenta Residence	NR	45	40
294	1st House North of Magenta	NR	5	12
295	2nd House North of Magenta	NR	7	6
296	M-5 Site	NR	10	5
297	House North of M-5	NR	28	17
298	Bailey Residence	NR	5	9
299	1st House North of Bailey	NR	15	25
300	Morris Residence	NR	10	5
301	1st House North of Morris	NR	5	5
302	2nd House North of Morris	NR	10	11
303	3rd House North of Morris	NR	5	10
304	4th House North of Morris	NR	0	0
305	5th House North of Morris	NR	0	1

Site	Site Name	2012 Total	2013 Total	2014 Total
306	Rothman Residence	NR	115	9
307	Lighthouse Point	NR	29	40
308	1st House North of Lighthouse Point	NR	45	6
309	2nd House North of Light House Point	NR	53	13
310	3rd House North of Light House Point	NR	0	32
311	4th House North of Light House Point	NR	13	5
312	5th House North of Light House Point	NR	10	1
313	6th House North of Light House Point	NR	0	2
314	2830 West Lake Drive	NR	0	0
315	“B.S. Boulevard “	NR	13	4
316	1st House North of “B.S. Boulevard”	NR	0	0
317	McQuan Residence	NR	0	1
318	2870- Debasio Residence	NR	2	7
319	Vanderholt Residence	NR	3	17
320	Martin Residence	NR	9	3
321	2900 – Mitchell Residence	NR	3	21
322	1st House North of Mitchell	NR	4	0
323	2nd House North of Mitchell	NR	0	1
324	3rd House North of Mitchell	NR	41	13
325	4th House North of Mitchell	NR	0	13
326	Harder Residence	NR	6	16
327	1st House North of Harder	NR	20	20
328	Burn Out Lot	NR	17	0
329	Thom Residence	NR	12	0
330	2990 West Lake	NR	3	0
331	3000 West Lake	NR	6	0
332	3010 West Lake	NR	10	4
333	Gill Residence	NR	32	11
334	2nd House North of 3010 West Lake	NR	12	2
335	Cutler Residence	NR	0	2
336	1st House North of Cutler	NR	0	0
337	3030 West Lake	NR	4	0
338	3040 West Lake	NR	2	0
339	3044 West Lake	NR	8	1
340	3050 West Lake	NR	4	1

Site	Site Name	2012 Total	2013 Total	2014 Total
341	Chase Point	NR	8	1
342	Wallace Residence	NR	0	1
343	Logan's Landing	NR	0	0
344	1st House North of Logan's Landing	NR	6	0
345	2nd House North of Logan's Landing	NR	15	0
346	3rd House North of Logan's Landing	NR	0	8
347	3104 West Lake	NR	0	0
348	3112 West Lake "Pebble Beach"	NR	0	0
349	1st House North of 3112 West Lake	NR	0	5
350	2nd House North of 3112 West Lake	NR	0	0
351	3140 West Lake	NR	1	4
352	3144 West Lake	NR	5	0
353	3148 West Lake- Elkerton Residence	NR	0	0
354	3152 West Lake- Wolfe Residence	NR	0	0
355	3156 West Lake- Merrett Residence	NR	0	0
356	3160 West Lake	NR	0	4
357	Chrisfield Residence	NR	3	6
358	1st House North of Chrisfield	NR	15	40
359	3172 West Lake	NR	75	46
360	Behrens Residence	NR	40	15
361	1st House North of Behrens	NR	12	11
362	3184 West Lake- Rizzuto Residence	NR	0	5
363	3188 West Lake	NR	3	2
364	Bowen Residence	NR	1	0
365	Gill Creek	NR	1	0
366	1st House North of Gill Creek	NR	0	0
367	3196 West Lake	NR	3	0
368	3210 West Lake	NR	4	0
369	3220 West Lake	NR	11	0
370	3230 West Lake	NR	5	1
371	3240 West Lake	NR	4	4
372	3250 West Lake	NR	5	3
373	3260 West Lake	NR	4	0
374	3270 West Lake	NR	15	3

Site	Site Name	2012 Total	2013 Total	2014 Total
375	3280 West Lake	NR	2	0
376	3290 West Lake	NR	0	10
377	Alton Residence	NR	5	10
378	Gray Residence	NR	6	0
379	1st House North of Gray	NR	0	0
380	Shoreline South of Starchuck	NR	0	0
381	Starchuck Provincial Campsite	NR	0	7
382	3560 West Lake	NR	0	0
383	3570 West Lake	NR	0	5
384	1st House North of 3570 West Lake	NR	10	2
385	2nd House North of 3570 West Lake	NR	170	100
386	3rd House North of 3570 West Lake	NR	10	15
387	4th House North of 3570 West Lake	NR	5	10
388	5th House North of 3570 West Lake	NR	0	6
389	6th House North of 3570 West Lake	NR	0	2
390	3628 West Lake- "Nine North"	NR	1	0
391	McCormack Residence	NR	0	1
392	1st House North of McCormack	NR	2	0
393	2nd House North of McCormack	NR	0	8
394	3rd House North of McCormack	NR	0	4
395	4th House North of McCormack	NR	1	2
396	5th House North of McCormack	NR	0	2
397	3670 West Lake- Clark Residence	NR	2	6
398	Randall Residence	NR	0	0
399	3686 West Lake	NR	0	2
400	McPeek Residence	NR	3	1
401	3698 West Lake Residence	NR	310	75
402	Rocky Beach Provincial Campsite	NR	530	10
403	Axel Johnson Provincial Campsite	NR	1335	638
404	Rock Slide	NR	38	9
405	Shoreline North of Rockslide	NR	36	11
406	4000 West Lake- Garber's Point	NR	18	6
407	4006 West Lake	NR	25	50
408	4012 West Lake	NR	5	16
409	4020 West Lake- Bernard Residence	NR	6	5
410	1st House North of Bernard	NR	6	0

Site	Site Name	2012 Total	2013 Total	2014 Total
411	4030 West Lake	NR	0	1
412	4034 West Lake	NR	9	1
413	1st House South of Ios Residence	NR	1102	675
414	Ios Residence	NR	1550	770
415	4046 West Lake	NR	1145	13
416	Creek North of Garber's Point	NR	1005	4
417	1st House South of Treadmill Creek	NR	465	10
418	Treadmill Creek Provincial Campsite	NR	7515	44
419	1st House North of Treadmill Creek	NR	5315	21
420	McTeer Residence	NR	1480	65
421	Shoreline North of McTeer	NR	432	40
422	Ricvibeils Residence	NR	43	34
423	1st House North of Ricvibeils	NR	40	223
424	4206 West Lake	NR	14	14
425	4212 West Lake	NR	16	5
426	Parson Creek Provincial Campsite	NR	159	16
427	Zin Bin Residence	NR	55	24
428	4230 West Lake	NR	8	23
429	1st House North of 4230 West Lake	NR	2	25
430	2nd House North of 4230 West Lake	NR	0	15
431	3rd House North of 4230 West Lake	NR	12	7
432	4258 West Lake	NR	220	23
433	4260 West Lake	NR	85	10
434	4266 West Lake- Davis Residence	NR	50	21
435	Klavers Residence	NR	10	25
436	4278 West Lake- Macaulay Residence	NR	10	34
437	4284 West Lake	NR	635	68
438	4290 West Lake- Snooks Residence	NR	225	18
439	Laetitia Maxima Residence	NR	150	2
440	1st House North of Laetitia Maxima	NR	75	8
441	2nd House North of Laetitia Maxima	NR	250	2
442	3rd House North of Laetitia Maxima	NR	130	91
443	Red Ochre Creek	NR	2750	475

Site	Site Name	2012 Total	2013 Total	2014 Total
444	Ole Johnson Provincial Campsite	NR	8940	775
445	Shoreline North of Ole Johnson	NR	583	913
446	1st House North of Ole Johnson	NR	680	35
447	4520 West Lake	NR	223	15
448	4530 West Lake	NR	460	74
449	1st House North of 4530 West Lake	NR	2690	34
450	2nd House North of 4530 West Lake	NR	1570	50
451	4580 West Lake	NR	770	48
452	1st House North of 4580 West Lake	NR	195	72
453	Tessmer Residence	NR	230	103
454	1st House North of Tessmer	NR	110	70
455	4620 West Lake	NR	100	80
456	Last House on the West Side	NR	186	151
457	Troy Creek Provincial Campsite	NR	15750	1393
458	North Bay Lagoon	NR	0	5900
459	Sander Creek	NR	2400	9
460	Sander Properties	NR	410	1175
461	Turtle Bay	NR	1400	310
462	Shoreline South of Turtle Bay	NR	60	160
463	1st House South of Turtle Bay	NR	100	5
464	4074 East Lake	NR	35	6
465	Pickering Residence	NR	20	11
466	1st House South of Pickering	NR	20	5
467	2nd House South of Pickering	NR	45	5
468	4535 East Lake- Simpson Residence	NR	90	38
469	Arnel Residence	NR	86	5
470	4665 East Lake- Macauley Residence	NR	70	4
471	1st House South of Macauley	NR	10	1
472	2nd House South of Macauley	NR	10	0
473	3rd House South of Macauley	NR	12	2
474	4th House South of Macauley	NR	5	0
475	Shoreline North of Trapper Creek #1	NR	316	2
476	Shoreline North of Trapper Creek #2	NR	65	9
477	Trapper Creek Campsite- North	NR	155	8
478	Trapper Creek Campsite- South	NR	27	28
479	Shoreline South of Trapper Creek	NR	150	40

Site	Site Name	2012 Total	2013 Total	2014 Total
480	Far Rocks Residence	NR	120	15
481	4005 East Lake- Pavan Residence	NR	0	4
482	Shoreline South of Pavan	NR	217	25
483	Meanly Residence	NR	24	11
484	Thomas Residence	NR	18	21
485	Shoreline South of Thomas	NR	432	21
486	Indian Rocks	NR	80	0
487	Texas Point Provincial Campgrounds	NR	64	34
488	Tambellini Residence	NR	41	0
489	1st House South of Tambellini	NR	4	3
490	2nd House South of Tambellini	NR	3	2
491	3rd House South of Tambellini	NR	0	0
492	4th House South of Tambellini	NR	0	0
493	5th House South of Tambellini	NR	0	0
494	6th House South of Tambellini	NR	0	5
495	Sommerville Residence	NR	0	0
496	Jackson Residence	NR	0	0
497	Fairweather Residence	NR	0	0
498	1st House South of Fairweather	NR	0	0
499	2nd House South of Fairweather	NR	0	0
500	3rd House South of Fairweather	NR	10	5
501	4th House South of Fairweather	NR	0	2
502	3rd House North of Boat Launch	NR	0	2
503	2nd House North of Boat Launch	NR	0	5
504	1st House North of Boat Launch	NR	0	12
505	Texas Point Boat Launch	NR	240	20
506	1st House South of Boat Launch	NR	197	78
507	Lorimer Residence	NR	1017	13
508	Walker Residence	NR	305	0
509	Deudney/Sperry Residence	NR	261	20
510	Texas Creek	NR	255	8
511	1st House South of Texas Creek	NR	0	2
512	2nd House South of Texas Creek	NR	0	0
513	3rd House South of Texas Creek	NR	10	0
514	4th House South of Texas Creek	NR	0	0
515	Lloyd Residence	NR	0	0
516	Kruger Residence	NR	21	0
517	1st House of North of Young's	NR	0	0
518	Young Residence	NR	0	0
519	Armstrong Residence	NR	0	0
520	Armstrong Residence #2	NR	0	0

Site	Site Name	2012 Total	2013 Total	2014 Total
521	Armstrong Residence #3	NR	0	2
522	1st House South of Armstrong #3	NR	2	0
523	1st House North of McMeekan	NR	0	0
524	McMeekan Residence	NR	0	2
525	Livingstone Residence	NR	300	82
526	Thorpe Residence	NR	8	20
527	3359 East Lake Drive- Gilmore	NR	0	0
528	Grandison Residence	NR	0	0
529	Stanley Residence	NR	0	0
530	Dennler Residence	NR	354	310
531	Wilson Residence	NR	5	10
532	Boucherane Residence	NR	0	0
533	Gabano Residence	NR	0	2
534	Anderson Residence	NR	0	0
535	Duncan Residence	NR	0	7
536	1st House South of Duncan	NR	0	0
537	Coleman Residence	NR	0	0
538	1st House South of Coleman	NR	0	0
539	Catelanno Residence	NR	0	0
540	1st House South of Catelanno	NR	15	19
541	McGauley Residence	NR	15	0
542	Whitley Residence	NR	15	0
543	1st House South of Whitley	NR	0	1
544	Draper Residence	NR	0	0
545	1st House South of Draper	NR	20	4
546	2nd House South of Draper	NR	0	2
547	3rd House South of Draper	NR	14	2
548	Petersen Residence	NR	0	8
549	1st House South of Petersen	NR	0	0
550	2nd House South of Petersen	NR	1	2
551	Bush Residence	NR	1	0
552	Wiltshire Residence	NR	51	1
553	1st House South of Wiltshire	NR	0	3
554	2nd House South of Wiltshire	NR	5	0
555	3rd House South of Wiltshire	NR	3	0
556	Wolfram Residence	NR	3	0
557	1st House South of Wolfram	NR	0	0
558	Round House	NR	6500	0
559	1st House North of Mathers	NR	0	1
560	Mathers Residence	NR	4	6
561	Deadmarsh Residence	NR	1	2
562	1st House South of Deadmarsh	NR	0	0

Site	Site Name	2012 Total	2013 Total	2014 Total
563	Shuteck Residence	NR	0	1
564	1st House South of Shuteck	NR	0	0
565	3rd House South of Shuteck	NR	0	16
566	4th House South of Shuteck	NR	21	22
567	5th House South of Shuteck	NR	0	30
568	4th House North of Hillard	NR	0	30
569	3rd House North of Hillard	NR	6	35
570	2nd House North of Hillard	NR	300	30
571	1st House North of Hillard	NR	1	10
572	Hillard Residence	NR	2	0
573	McRae Creek	NR	0	0
574	Benson Residence	NR	0	0
575	1st House North of Marina	NR	0	0
C. Creek	Christina Creek	NR	NR	2000

NR = Not Reported, sites not established

APPENDIX B

Insects captured on terrestrial sticky traps, placed September and October 2013 near the shoreline of Christina Lake, B.C., raw data

Card # (grid)	Placement Date	Collection Date	Side (A/B)	Insect	Rating
1	22-Sep-13	29-Sep-13	A	Thrips (Order: Thysanoptera)	1
1	22-Sep-13	29-Sep-13	A	Coleoptera	1
1	22-Sep-13	29-Sep-13	A	Hemiptera, Aphididae	1
1	22-Sep-13	29-Sep-13	A	Slug (Class: Gastropoda)	1
1	22-Sep-13	29-Sep-13	A	Arachnida, Araneae	1
1	22-Sep-13	29-Sep-13	A	Odonata	1
1	22-Sep-13	29-Sep-13	A	Hemiptera, Cicadellidae	1
1	22-Sep-13	29-Sep-13	A	Hymenoptera, Parasitoid	2
1	22-Sep-13	29-Sep-13	A	Diptera	2
1	22-Sep-13	29-Sep-13	B	Hemiptera, Aphididae	1
1	22-Sep-13	29-Sep-13	B	Collembola	1
1	22-Sep-13	29-Sep-13	B	Hemiptera, Cicadellidae, Typhlocybinae	1
1	22-Sep-13	29-Sep-13	B	Coleoptera	1
1	22-Sep-13	29-Sep-13	B	Hemiptera, Cicadellidae	1
1	22-Sep-13	29-Sep-13	B	Coleoptera	1
1	22-Sep-13	29-Sep-13	B	Hymenoptera, Formicidae	1
1	22-Sep-13	29-Sep-13	B	Diptera	2
1	22-Sep-13	29-Sep-13	B	Arachnida, Araneae	2
1	22-Sep-13	29-Sep-13	B	Hymenoptera, Parasitoid	3
2	22-Sep-13	29-Sep-13	A	Hymenoptera, Formicidae	1
2	22-Sep-13	29-Sep-13	A	Hemiptera, Cicadellidae, Typhlocybinae	1
2	22-Sep-13	29-Sep-13	A	Diptera	1

Card # (grid)	Placement Date	Collection Date	Side (A/B)	Insect	Rating
2	22-Sep-13	29-Sep-13	A	Hemiptera, Cicadellidae, Macrosteles	1
2	22-Sep-13	29-Sep-13	A	Hymenoptera, Parasitoid	2
2	22-Sep-13	29-Sep-13	A	Hemiptera, Aphididae	2
2	22-Sep-13	29-Sep-13	A	Coleoptera	2
2	22-Sep-13	29-Sep-13	B	Coleoptera	1
2	22-Sep-13	29-Sep-13	B	Diptera	2
2	22-Sep-13	29-Sep-13	B	Hemiptera, Aphididae	2
2	22-Sep-13	29-Sep-13	B	Hymenoptera, Parasitoid	3
3	22-Sep-13	29-Sep-13	A	Hemiptera, Aphididae	1
3	22-Sep-13	29-Sep-13	A	Arachnida, Araneae	1
3	22-Sep-13	29-Sep-13	A	Slug (Class: Gastropoda)	1
3	22-Sep-13	29-Sep-13	A	Coleoptera	2
3	22-Sep-13	29-Sep-13	A	Diptera	3
3	22-Sep-13	29-Sep-13	A	Hymenoptera, Parasitoid	3
3	22-Sep-13	29-Sep-13	B	Coleoptera	1
3	22-Sep-13	29-Sep-13	B	Arachnida, Araneae	1
3	22-Sep-13	29-Sep-13	B	Diptera	2
3	22-Sep-13	29-Sep-13	B	Hemiptera, Aphididae	2
3	22-Sep-13	29-Sep-13	B	Hymenoptera, Parasitoid	3
4	22-Sep-13	29-Sep-13	A	Coleoptera	1
4	22-Sep-13	29-Sep-13	A	Diptera	3
4	22-Sep-13	29-Sep-13	A	Hemiptera, Aphididae	3
4	22-Sep-13	29-Sep-13	A	Hymenoptera, Parasitoid	3
4	22-Sep-13	29-Sep-13	B	Coleoptera	1
4	22-Sep-13	29-Sep-13	B	Hemiptera, Cicadellidae, Typhlocybinae	1
4	22-Sep-13	29-Sep-13	B	Hymenoptera, Formicidae	1
4	22-Sep-13	29-Sep-13	B	Diptera	2
4	22-Sep-13	29-Sep-13	B	Hemiptera, Aphididae	3

Card # (grid)	Placement Date	Collection Date	Side (A/B)	Insect	Rating
4	22-Sep-13	29-Sep-13	B	Hymenoptera, Parasitoid	3
5	22-Sep-13	29-Sep-13	A	Coleoptera	1
5	22-Sep-13	29-Sep-13	A	Diptera	2
5	22-Sep-13	29-Sep-13	A	Hemiptera, Aphididae	2
5	22-Sep-13	29-Sep-13	A	Hymenoptera, Parasitoid	3
5	22-Sep-13	29-Sep-13	B	Coleoptera	1
5	22-Sep-13	29-Sep-13	B	Hemiptera, Aphididae	1
5	22-Sep-13	29-Sep-13	B	Hymenoptera, Formicidae	1
5	22-Sep-13	29-Sep-13	B	Diptera	3
5	22-Sep-13	29-Sep-13	B	Hymenoptera, Parasitoid	3
6	22-Sep-13	29-Sep-13	A	Hemiptera, Cicadellidae	1
6	22-Sep-13	29-Sep-13	A	Hymenoptera, Formicidae	1
6	22-Sep-13	29-Sep-13	A	Coleoptera	1
6	22-Sep-13	29-Sep-13	A	Collembola	1
6	22-Sep-13	29-Sep-13	A	Hemiptera, Cicadellidae	1
6	22-Sep-13	29-Sep-13	A	Arachnida, Araneae	1
6	22-Sep-13	29-Sep-13	A	Diptera	1
6	22-Sep-13	29-Sep-13	A	Hemiptera, Cicadellidae	1
6	22-Sep-13	29-Sep-13	A	Diptera	2
6	22-Sep-13	29-Sep-13	A	Coleoptera	2
6	22-Sep-13	29-Sep-13	A	Hymenoptera, Parasitoid	2
6	22-Sep-13	29-Sep-13	A	Hymenoptera, Parasitoid	3
6	22-Sep-13	29-Sep-13	A	Diptera	3
6	22-Sep-13	29-Sep-13	A	Hymenoptera, Parasitoid	3
6	22-Sep-13	29-Sep-13	A	Hemiptera, Aphididae	3
6	22-Sep-13	29-Sep-13	B	Hemiptera, Cicadellidae	1
6	22-Sep-13	29-Sep-13	B	Hemiptera	1
6	22-Sep-13	29-Sep-13	B	Hemiptera, Cicadellidae	1
6	22-Sep-13	29-Sep-13	B	Diptera	1
6	22-Sep-13	29-Sep-13	B	Hemiptera, Cicadellidae	1
6	22-Sep-13	29-Sep-13	B	Coleoptera	1
6	22-Sep-13	29-Sep-13	B	Arachnida, Araneae	1

Card # (grid)	Placement Date	Collection Date	Side (A/B)	Insect	Rating
6	22-Sep-13	29-Sep-13	B	Diptera	2
6	22-Sep-13	29-Sep-13	B	Hymenoptera, Parasitoid	2
6	22-Sep-13	29-Sep-13	B	Hymenoptera, Parasitoid	3
6	22-Sep-13	29-Sep-13	B	Hemiptera, Aphididae	3
6	22-Sep-13	29-Sep-13	B	Hymenoptera, Parasitoid	3
7	22-Sep-13	29-Sep-13	A	Hemiptera, Cicadellidae, Macrosteles	1
7	22-Sep-13	29-Sep-13	A	Coleoptera, Coccinellidae	1
7	22-Sep-13	29-Sep-13	A	Diptera	1
7	22-Sep-13	29-Sep-13	A	Arachnida, Araneae	1
7	22-Sep-13	29-Sep-13	A	Hymenoptera, Formicidae	2
7	22-Sep-13	29-Sep-13	A	Hymenoptera, Parasitoid	2
7	22-Sep-13	29-Sep-13	A	Hymenoptera, Formicidae	2
7	22-Sep-13	29-Sep-13	A	Coleoptera	2
7	22-Sep-13	29-Sep-13	A	Hemiptera, Aphididae	3
7	22-Sep-13	29-Sep-13	A	Diptera	3
7	22-Sep-13	29-Sep-13	A	Hymenoptera, Parasitoid	3
7	22-Sep-13	29-Sep-13	B	Hymenoptera, Formicidae	1
7	22-Sep-13	29-Sep-13	B	Coleoptera	1
7	22-Sep-13	29-Sep-13	B	Hemiptera, Cicadellidae, Typhlocybinae	1
7	22-Sep-13	29-Sep-13	B	Orthoptera	1
7	22-Sep-13	29-Sep-13	B	Hymenoptera, Formicidae	1
7	22-Sep-13	29-Sep-13	B	Hemiptera, Cicadellidae	1
7	22-Sep-13	29-Sep-13	B	Hymenoptera, Parasitoid	2
7	22-Sep-13	29-Sep-13	B	Arachnida, Araneae	2
7	22-Sep-13	29-Sep-13	B	Diptera	2

Card # (grid)	Placement Date	Collection Date	Side (A/B)	Insect	Rating
7	22-Sep-13	29-Sep-13	B	Diptera	3
7	22-Sep-13	29-Sep-13	B	Coleoptera	3
7	22-Sep-13	29-Sep-13	B	Hymenoptera, Parasitoid	3
8	22-Sep-13	29-Sep-13	A	Hemiptera, Cicadellidae	1
8	22-Sep-13	29-Sep-13	A	Collembola	1
8	22-Sep-13	29-Sep-13	A	Thrips (Order: Thysanoptera)	1
8	22-Sep-13	29-Sep-13	A	Diptera	2
8	22-Sep-13	29-Sep-13	A	Hymenoptera, Parasitoid	3
8	22-Sep-13	29-Sep-13	B	Arachnida, Araneae	1
8	22-Sep-13	29-Sep-13	B	Hemiptera, Aphididae	1
8	22-Sep-13	29-Sep-13	B	Hemiptera, Cicadellidae	1
8	22-Sep-13	29-Sep-13	B	Diptera	2
8	22-Sep-13	29-Sep-13	B	Hymenoptera, Parasitoid	3
9	22-Sep-13	29-Sep-13	A	Hymenoptera, Formicidae	1
9	22-Sep-13	29-Sep-13	A	Odonata	1
9	22-Sep-13	29-Sep-13	A	Hemiptera, Cicadellidae	2
9	22-Sep-13	29-Sep-13	A	Arachnida, Araneae	2
9	22-Sep-13	29-Sep-13	A	Coleoptera	3
9	22-Sep-13	29-Sep-13	A	Diptera	3
9	22-Sep-13	29-Sep-13	A	Hymenoptera, Parasitoid	3
9	22-Sep-13	29-Sep-13	B	Hemiptera, unknown	1
9	22-Sep-13	29-Sep-13	B	Hemiptera, Aphididae	1
9	22-Sep-13	29-Sep-13	B	Arachnida, Araneae	2
9	22-Sep-13	29-Sep-13	B	Diptera	2
9	22-Sep-13	29-Sep-13	B	Coleoptera	3
10	22-Sep-13	29-Sep-13	A	Arachnida, Araneae	1
10	22-Sep-13	29-Sep-13	A	Hymenoptera, Parasitoid	1
10	22-Sep-13	29-Sep-13	A	Diptera	2
10	22-Sep-13	29-Sep-13	A	Hemiptera, Aphididae	2
10	22-Sep-13	29-Sep-13	A	Diptera	
10	22-Sep-13	29-Sep-13	B	Gastropoda (snail)	1
10	22-Sep-13	29-Sep-13	B	Diptera	2

Card # (grid)	Placement Date	Collection Date	Side (A/B)	Insect	Rating
10	22-Sep-13	29-Sep-13	B	Hemiptera, Aphididae	3
11	22-Sep-13	29-Sep-13	A	Diptera	1
11	22-Sep-13	29-Sep-13	A	Hymenoptera, Parasitoid	1
11	22-Sep-13	29-Sep-13	A	Hemiptera, Aphididae	1
11	22-Sep-13	29-Sep-13	A	Arachnida, Araneae	1
11	22-Sep-13	29-Sep-13	A	Diptera	1
11	22-Sep-13	29-Sep-13	A	Thrips (Order: Thysanoptera)	1
11	22-Sep-13	29-Sep-13	A	Coleoptera	2
11	22-Sep-13	29-Sep-13	A	Hymenoptera, Parasitoid	3
11	22-Sep-13	29-Sep-13	A	Hemiptera, Cicadellidae	3
11	22-Sep-13	29-Sep-13	B	Coleoptera	1
11	22-Sep-13	29-Sep-13	B	Hemiptera, Cicadellidae	1
11	22-Sep-13	29-Sep-13	B	Arachnida, Araneae	1
11	22-Sep-13	29-Sep-13	B	Diptera	2
11	22-Sep-13	29-Sep-13	B	Hemiptera, Aphididae	2
11	22-Sep-13	29-Sep-13	B	Diptera	2
11	22-Sep-13	29-Sep-13	B	Hymenoptera, Parasitoid	2
11	22-Sep-13	29-Sep-13	B	Hymenoptera, Parasitoid	3
12	22-Sep-13	29-Sep-13	A	Orthoptera	1
12	22-Sep-13	29-Sep-13	A	Unknown - damaged	1
12	22-Sep-13	29-Sep-13	A	Diptera midge (bright green)	1
12	22-Sep-13	29-Sep-13	A	Coleoptera	1
12	22-Sep-13	29-Sep-13	A	Diptera unknown	2
12	22-Sep-13	29-Sep-13	A	Hymenoptera, Parasitoid	3
12	22-Sep-13	29-Sep-13	B	Diptera, unknown	1
12	22-Sep-13	29-Sep-13	B	Arachnida, Araneae	1
12	22-Sep-13	29-Sep-13	B	Slug (Class: Gastropoda)	1
12	22-Sep-13	29-Sep-13	B	Hymenoptera, Parasitoid	2
13	22-Sep-13	29-Sep-13	A	Arachnida, Araneae	1
13	22-Sep-13	29-Sep-13	A	Hymenoptera, Parasitoid	1

Card # (grid)	Placement Date	Collection Date	Side (A/B)	Insect	Rating
13	22-Sep-13	29-Sep-13	A	Hemiptera, Aphididae	1
13	22-Sep-13	29-Sep-13	A	Diptera	1
13	22-Sep-13	29-Sep-13	A	Hemiptera, Cicadellidae	1
13	22-Sep-13	29-Sep-13	A	Gastropoda - snail	1
13	22-Sep-13	29-Sep-13	A	Hymenoptera, Formicidae	1
13	22-Sep-13	29-Sep-13	A	Coleoptera	1
13	22-Sep-13	29-Sep-13	B	Gastropoda - snail	1
13	22-Sep-13	29-Sep-13	B	Hemiptera, Aphididae	1
14	22-Sep-13	29-Sep-13	A	Arachnida, Araneae	1
14	22-Sep-13	29-Sep-13	A	Coleoptera	1
14	22-Sep-13	29-Sep-13	A	Diptera	2
14	22-Sep-13	29-Sep-13	A	Hymenoptera, Parasitoid	2
14	22-Sep-13	29-Sep-13	A	Hemiptera, Cicadellidae	2
14	22-Sep-13	29-Sep-13	A	Hemiptera, Aphididae	3
14	22-Sep-13	29-Sep-13	B	Coleoptera	1
14	22-Sep-13	29-Sep-13	B	Hymenoptera, Parasitoid	2
14	22-Sep-13	29-Sep-13	B	Diptera	3
14	22-Sep-13	29-Sep-13	B	Hemiptera, Aphididae	3
15	22-Sep-13	29-Sep-13	A	Arachnida, Araneae	1
15	22-Sep-13	29-Sep-13	A	Coleoptera	1
15	22-Sep-13	29-Sep-13	A	Hemiptera, Cicadellidae	1
15	22-Sep-13	29-Sep-13	A	Odonata	1
15	22-Sep-13	29-Sep-13	A	Diptera	2
15	22-Sep-13	29-Sep-13	A	Hymenoptera, Parasitoid	2
15	22-Sep-13	29-Sep-13	A	Hymenoptera, Parasitoid	3
15	22-Sep-13	29-Sep-13	A	Hymenoptera, Vespidae	3
15	22-Sep-13	29-Sep-13	A	Diptera	3
15	22-Sep-13	29-Sep-13	B	Hemiptera, Cicadellidae, Typhlocybinae	1
15	22-Sep-13	29-Sep-13	B	Coleoptera	1
15	22-Sep-13	29-Sep-13	B	Hemiptera, Cicadellidae	1
15	22-Sep-13	29-Sep-13	B	Hemiptera, Aphididae	2
15	22-Sep-13	29-Sep-13	B	Diptera	2
15	22-Sep-13	29-Sep-13	B	Diptera	2

Card # (grid)	Placement Date	Collection Date	Side (A/B)	Insect	Rating
15	22-Sep-13	29-Sep-13	B	Hymenoptera, Parasitoid	2
15	22-Sep-13	29-Sep-13	B	Hymenoptera, Parasitoid	3
16	22-Sep-13	29-Sep-13	A	Arachnida, Araneae	1
16	22-Sep-13	29-Sep-13	A	Coleoptera	1
16	22-Sep-13	29-Sep-13	A	Hemiptera, Cicadellidae, Typhlocybinae	1
16	22-Sep-13	29-Sep-13	A	Coleoptera, Coccinellidae	1
16	22-Sep-13	29-Sep-13	A	Coleoptera, Coccinellidae	1
16	22-Sep-13	29-Sep-13	A	Hemiptera, Aphididae	1
16	22-Sep-13	29-Sep-13	A	Odonata	1
16	22-Sep-13	29-Sep-13	A	Arachnida, Araneae	1
16	22-Sep-13	29-Sep-13	A	Hymenoptera, Formicidae	1
16	22-Sep-13	29-Sep-13	A	Hemiptera, Aphididae	2
16	22-Sep-13	29-Sep-13	A	Hymenoptera, Formicidae	2
16	22-Sep-13	29-Sep-13	A	Hymenoptera, Parasitoid	2
16	22-Sep-13	29-Sep-13	A	Diptera	2
16	22-Sep-13	29-Sep-13	A	Hymenoptera, Parasitoid	2
16	22-Sep-13	29-Sep-13	A	Hymenoptera, Parasitoid	3
16	22-Sep-13	29-Sep-13	A	Diptera	3
16	22-Sep-13	29-Sep-13	A	Diptera	3
16	22-Sep-13	29-Sep-13	A	Hemiptera, Cicadellidae, Typhlocybinae	3
16	22-Sep-13	29-Sep-13	B	Arachnida, Araneae	1
16	22-Sep-13	29-Sep-13	B	Coleoptera	1
16	22-Sep-13	29-Sep-13	B	Arachnida, Araneae	1
16	22-Sep-13	29-Sep-13	B	Hemiptera, Cicadellidae	1
16	22-Sep-13	29-Sep-13	B	Hymenoptera, Parasitoid	2
16	22-Sep-13	29-Sep-13	B	Diptera	2

Card # (grid)	Placement Date	Collection Date	Side (A/B)	Insect	Rating
16	22-Sep-13	29-Sep-13	B	Hemiptera, Aphididae	2
16	22-Sep-13	29-Sep-13	B	Hemiptera, Aphididae	3
16	22-Sep-13	29-Sep-13	B	Hymenoptera, Parasitoid	3
16	22-Sep-13	29-Sep-13	B	Diptera	3
16	22-Sep-13	29-Sep-13	B	Hemiptera, Cicadellidae, Typhlocybinae	3
17	22-Sep-13	29-Sep-13	A	Hemiptera, Cicadellidae, Macrosteles	1
17	22-Sep-13	29-Sep-13	A	Thrips (Order: Thysanoptera)	1
17	22-Sep-13	29-Sep-13	A	Collembola	1
17	22-Sep-13	29-Sep-13	A	Hymenoptera, Formicidae	1
17	22-Sep-13	29-Sep-13	A	Odonata	1
17	22-Sep-13	29-Sep-13	A	Lepidoptera	1
17	22-Sep-13	29-Sep-13	A	Hemiptera, Cicadellidae	1
17	22-Sep-13	29-Sep-13	A	Arachnida, Araneae	2
17	22-Sep-13	29-Sep-13	A	Hymenoptera, Parasitoid	2
17	22-Sep-13	29-Sep-13	A	Hemiptera, Aphididae	3
17	22-Sep-13	29-Sep-13	A	Diptera	3
17	22-Sep-13	29-Sep-13	A	Hymenoptera, Parasitoid	3
17	22-Sep-13	29-Sep-13	A	Diptera	3
17	22-Sep-13	29-Sep-13	B	Lepidoptera	1
17	22-Sep-13	29-Sep-13	B	Arachnida, Araneae	1
17	22-Sep-13	29-Sep-13	B	Collembola	1
17	22-Sep-13	29-Sep-13	B	Hymenoptera, Formicidae	1
17	22-Sep-13	29-Sep-13	B	Diptera	1
17	22-Sep-13	29-Sep-13	B	Hemiptera, Cicadellidae	1
17	22-Sep-13	29-Sep-13	B	Arachnida, Araneae	1
17	22-Sep-13	29-Sep-13	B	Diptera	2
17	22-Sep-13	29-Sep-13	B	Hemiptera, Aphididae	3
17	22-Sep-13	29-Sep-13	B	Hymenoptera, Parasitoid	3
18	22-Sep-13	29-Sep-13	A	Hemiptera, Cicadellidae	1

Card # (grid)	Placement Date	Collection Date	Side (A/B)	Insect	Rating
18	22-Sep-13	29-Sep-13	A	Diptera	2
18	22-Sep-13	29-Sep-13	A	Hemiptera, Aphididae	2
18	22-Sep-13	29-Sep-13	A	Hymenoptera, Parasitoid	3
18	22-Sep-13	29-Sep-13	B	Arachnida, Araneae	1
18	22-Sep-13	29-Sep-13	B	Hemiptera, Cicadellidae	1
18	22-Sep-13	29-Sep-13	B	Coleoptera	1
18	22-Sep-13	29-Sep-13	B	Hemiptera, Cicadellidae, Typhlocybiniae	1
18	22-Sep-13	29-Sep-13	B	Hemiptera, Aphididae	2
18	22-Sep-13	29-Sep-13	B	Diptera	2
18	22-Sep-13	29-Sep-13	B	Hymenoptera, Parasitoid	3
19	22-Sep-13	29-Sep-13	A	Odonata	1
19	22-Sep-13	29-Sep-13	A	Arachnida, Araneae	1
19	22-Sep-13	29-Sep-13	A	Hemiptera, Cicadellidae	1
19	22-Sep-13	29-Sep-13	A	Diptera	3
19	22-Sep-13	29-Sep-13	A	Hymenoptera, Formicidae	3
19	22-Sep-13	29-Sep-13	A	Hymenoptera, Parasitoid	3
19	22-Sep-13	29-Sep-13	B	Arachnida, Araneae	1
19	22-Sep-13	29-Sep-13	B	Diptera	1
19	22-Sep-13	29-Sep-13	B	Hemiptera, Cicadellidae	1
19	22-Sep-13	29-Sep-13	B	Hymenoptera, Formicidae	1
19	22-Sep-13	29-Sep-13	B	Hymenoptera, Parasitoid	2
20	22-Sep-13	29-Sep-13	A	Hymenoptera, Parasitoid	1
20	22-Sep-13	29-Sep-13	A	Arachnida, Araneae	1
20	22-Sep-13	29-Sep-13	A	Coleoptera	1
20	22-Sep-13	29-Sep-13	A	Diptera	3
20	22-Sep-13	29-Sep-13	A	Hymenoptera, Formicidae	3
20	22-Sep-13	29-Sep-13	B	Diptera	1
20	22-Sep-13	29-Sep-13	B	Coleoptera	1
20	22-Sep-13	29-Sep-13	B	Arachnida, Araneae	1

Card # (grid)	Placement Date	Collection Date	Side (A/B)	Insect	Rating
20	22-Sep-13	29-Sep-13	B	Hymenoptera, Formicidae	1
39	22-Sep-13	29-Sep-13	A	Hemiptera, Cicadellidae	1
39	22-Sep-13	29-Sep-13	A	Hymenoptera, Formicidae	1
39	22-Sep-13	29-Sep-13	A	Arachnida, Araneae	1
39	22-Sep-13	29-Sep-13	A	Coleoptera	1
39	22-Sep-13	29-Sep-13	A	Diptera	2
39	22-Sep-13	29-Sep-13	A	Hemiptera, Aphididae	3
39	22-Sep-13	29-Sep-13	A	Hymenoptera, Parasitoid	3
39	22-Sep-13	29-Sep-13	B	Arachnida, Araneae	1
39	22-Sep-13	29-Sep-13	B	Hemiptera, unknown	1
39	22-Sep-13	29-Sep-13	B	Diptera	3
39	22-Sep-13	29-Sep-13	B	Hemiptera, Aphididae	3
39	22-Sep-13	29-Sep-13	B	Hymenoptera, Parasitoid	3
40	22-Sep-13	29-Sep-13	A	Hemiptera, Aphididae	1
40	22-Sep-13	29-Sep-13	A	Coleoptera	1
40	22-Sep-13	29-Sep-13	A	Diptera	1
40	22-Sep-13	29-Sep-13	A	Hemiptera, Cicadellidae	1
40	22-Sep-13	29-Sep-13	A	Hymenoptera, Parasitoid	3
40	22-Sep-13	29-Sep-13	B	Coleoptera	1
40	22-Sep-13	29-Sep-13	B	Hemiptera, Cicadellidae	1
40	22-Sep-13	29-Sep-13	B	Hymenoptera, Parasitoid	3
41	22-Sep-13	29-Sep-13	A	Coleoptera	1
41	22-Sep-13	29-Sep-13	A	Hemiptera, Cicadellidae	1
41	22-Sep-13	29-Sep-13	A	Hymenoptera, Parasitoid	3
41	22-Sep-13	29-Sep-13	A	Diptera	3
41	22-Sep-13	29-Sep-13	B	Hemiptera, Cicadellidae	1
41	22-Sep-13	29-Sep-13	B	Coleoptera	1
41	22-Sep-13	29-Sep-13	B	Hemiptera, unknown	1
41	22-Sep-13	29-Sep-13	B	Hymenoptera, Parasitoid	3
41	22-Sep-13	29-Sep-13	B	Diptera	3
42	22-Sep-13	29-Sep-13	A	Coleoptera	1
42	22-Sep-13	29-Sep-13	A	Hemiptera, Aphididae	1

Card # (grid)	Placement Date	Collection Date	Side (A/B)	Insect	Rating
42	22-Sep-13	29-Sep-13	A	Diptera	2
42	22-Sep-13	29-Sep-13	A	Hymenoptera, Parasitoid	3
42	22-Sep-13	29-Sep-13	B	Hymenoptera, Formicidae	1
42	22-Sep-13	29-Sep-13	B	Hemiptera, Cicadellidae	2
42	22-Sep-13	29-Sep-13	B	Coleoptera	2
42	22-Sep-13	29-Sep-13	B	Diptera	3
42	22-Sep-13	29-Sep-13	B	Hymenoptera, Parasitoid	3
43	22-Sep-13	29-Sep-13	A	Coleoptera	1
43	22-Sep-13	29-Sep-13	A	Hemiptera, Aphididae	1
43	22-Sep-13	29-Sep-13	A	Diptera	2
43	22-Sep-13	29-Sep-13	A	Hymenoptera, Parasitoid	3
43	22-Sep-13	29-Sep-13	B	Diptera	1
43	22-Sep-13	29-Sep-13	B	Coleoptera	1
43	22-Sep-13	29-Sep-13	B	Hemiptera, Aphididae	1
43	22-Sep-13	29-Sep-13	B	Hymenoptera, Parasitoid	2
44	22-Sep-13	29-Sep-13	A	Coleoptera	1
44	22-Sep-13	29-Sep-13	A	Thrips (Order: Thysanoptera)	1
44	22-Sep-13	29-Sep-13	A	Diptera	2
44	22-Sep-13	29-Sep-13	A	Hymenoptera, Parasitoid	3
44	22-Sep-13	29-Sep-13	A	Hemiptera, Aphididae	3
44	22-Sep-13	29-Sep-13	B	Coleoptera	1
44	22-Sep-13	29-Sep-13	B	Diptera	2
44	22-Sep-13	29-Sep-13	B	Hymenoptera, Parasitoid	3
44	22-Sep-13	29-Sep-13	B	Hemiptera, Aphididae	3
45	22-Sep-13	29-Sep-13	A	Hemiptera, Cicadellidae	1
45	22-Sep-13	29-Sep-13	A	Hemiptera, Cicadellidae, Typhlocybinae	1
45	22-Sep-13	29-Sep-13	A	Hemiptera, Aphididae	1
45	22-Sep-13	29-Sep-13	A	Arachnida, Araneae	1
45	22-Sep-13	29-Sep-13	A	Diptera	2

Card # (grid)	Placement Date	Collection Date	Side (A/B)	Insect	Rating
45	22-Sep-13	29-Sep-13	A	Hymenoptera, Parasitoid	3
45	22-Sep-13	29-Sep-13	B	Collembola	1
45	22-Sep-13	29-Sep-13	B	Thrips (Order: Thysanoptera)	1
45	22-Sep-13	29-Sep-13	B	Hemiptera, Cicadellidae, Macrosteles	1
45	22-Sep-13	29-Sep-13	B	Diptera	2
45	22-Sep-13	29-Sep-13	B	Hemiptera, Aphididae	2
45	22-Sep-13	29-Sep-13	B	Hymenoptera, Parasitoid	3
46	22-Sep-13	29-Sep-13	A	Arachnida, Araneae	1
46	22-Sep-13	29-Sep-13	A	Hemiptera, Aphididae	2
46	22-Sep-13	29-Sep-13	A	Hemiptera, Cicadellidae	2
46	22-Sep-13	29-Sep-13	A	Coleoptera	2
46	22-Sep-13	29-Sep-13	A	Diptera	3
46	22-Sep-13	29-Sep-13	A	Hymenoptera, Parasitoid	3
46	22-Sep-13	29-Sep-13	B	Hemiptera, Cicadellidae	1
46	22-Sep-13	29-Sep-13	B	Hemiptera, Aphididae	2
46	22-Sep-13	29-Sep-13	B	Coleoptera	2
46	22-Sep-13	29-Sep-13	B	Diptera	3
46	22-Sep-13	29-Sep-13	B	Hymenoptera, Parasitoid	3
47	22-Sep-13	29-Sep-13	A	Hemiptera, Cicadellidae, Macrosteles	1
47	22-Sep-13	29-Sep-13	A	Diptera	2
47	22-Sep-13	29-Sep-13	A	Hymenoptera, Parasitoid	2
47	22-Sep-13	29-Sep-13	A	Hemiptera, Aphididae	2
47	22-Sep-13	29-Sep-13	B	Arachnida, Araneae	1
47	22-Sep-13	29-Sep-13	B	Hemiptera, Cicadellidae, Typhlocybinae	1
47	22-Sep-13	29-Sep-13	B	Hemiptera, Aphididae	2
47	22-Sep-13	29-Sep-13	B	Diptera	3
47	22-Sep-13	29-Sep-13	B	Hymenoptera, Parasitoid	3

Card # (grid)	Placement Date	Collection Date	Side (A/B)	Insect	Rating
48	22-Sep-13	29-Sep-13	A	Hemiptera, Cicadellidae, Typhlocybinae	1
48	22-Sep-13	29-Sep-13	A	mollusca, gastropoda	1
48	22-Sep-13	29-Sep-13	A	Acari	1
48	22-Sep-13	29-Sep-13	A	Hymenoptera, Parasitoid	2
48	22-Sep-13	29-Sep-13	B	Acari	1
48	22-Sep-13	29-Sep-13	B	Hemiptera, Aphididae	1
48	22-Sep-13	29-Sep-13	B	Coleoptera	1
48	22-Sep-13	29-Sep-13	B	Arachnida, Araneae	1
48	22-Sep-13	29-Sep-13	B	Hymenoptera, Parasitoid	3
48	22-Sep-13	29-Sep-13	B	Diptera	3
48	22-Sep-13	29-Sep-13	B	Hemiptera	3
49	22-Sep-13	29-Sep-13	A	Coleoptera	1
49	22-Sep-13	29-Sep-13	A	Hymenoptera, Parasitoid	3
49	22-Sep-13	29-Sep-13	A	Diptera	3
49	22-Sep-13	29-Sep-13	A	Hemiptera, Aphididae	3
49	22-Sep-13	29-Sep-13	B	Coleoptera	1
49	22-Sep-13	29-Sep-13	B	Diptera	2
49	22-Sep-13	29-Sep-13	B	Hemiptera, Cicadellidae	2
49	22-Sep-13	29-Sep-13	B	Hymenoptera, Parasitoid	3
49	22-Sep-13	29-Sep-13	B	Hemiptera, Aphididae	3
50	22-Sep-13	29-Sep-13	A	Arachnida, Araneae	1
50	22-Sep-13	29-Sep-13	A	Hemiptera, Cicadellidae	1
50	22-Sep-13	29-Sep-13	A	Hemiptera, Aphididae	3
50	22-Sep-13	29-Sep-13	A	Hymenoptera, Parasitoid	3
50	22-Sep-13	29-Sep-13	A	Diptera	3
50	22-Sep-13	29-Sep-13	B	Arachnida, Araneae	1
50	22-Sep-13	29-Sep-13	B	Hymenoptera, Parasitoid	1
50	22-Sep-13	29-Sep-13	B	Coleoptera	1
50	22-Sep-13	29-Sep-13	B	Diptera	2
50	22-Sep-13	29-Sep-13	B	Hemiptera, Aphididae	3
51	22-Sep-13	29-Sep-13	A	Acari	1

Card # (grid)	Placement Date	Collection Date	Side (A/B)	Insect	Rating
51	22-Sep-13	29-Sep-13	A	Hemiptera, Cicadellidae, Typhlocybinae	1
51	22-Sep-13	29-Sep-13	A	Hymenoptera, Formicidae	2
51	22-Sep-13	29-Sep-13	A	Hymenoptera, Parasitoid	2
51	22-Sep-13	29-Sep-13	A	Diptera	2
51	22-Sep-13	29-Sep-13	B	Hymenoptera, Formicidae	1
51	22-Sep-13	29-Sep-13	B	Hymenoptera, Parasitoid	1
52	22-Sep-13	29-Sep-13	A	Coleoptera	1
52	22-Sep-13	29-Sep-13	A	Hemiptera, Aphididae	1
52	22-Sep-13	29-Sep-13	A	Diptera	2
52	22-Sep-13	29-Sep-13	A	Hymenoptera, Parasitoid	2
52	22-Sep-13	29-Sep-13	A	Hemiptera, Cicadellidae	2
52	22-Sep-13	29-Sep-13	B	Hemiptera, Cicadellidae	1
52	22-Sep-13	29-Sep-13	B	Coleoptera	1
52	22-Sep-13	29-Sep-13	B	Hemiptera, Aphididae	2
52	22-Sep-13	29-Sep-13	B	Diptera	2
52	22-Sep-13	29-Sep-13	B	Hymenoptera, Parasitoid	3
53	22-Sep-13	29-Sep-13	A	Coleoptera	1
53	22-Sep-13	29-Sep-13	A	Diptera	2
53	22-Sep-13	29-Sep-13	A	Hymenoptera, Parasitoid	3
53	22-Sep-13	29-Sep-13	A	Hemiptera, Cicadellidae	3
53	22-Sep-13	29-Sep-13	A	Hemiptera, Aphididae	3
53	22-Sep-13	29-Sep-13	B	Slug (Class: Gastropoda)	1
53	22-Sep-13	29-Sep-13	B	Hemiptera, Cicadellidae	2
53	22-Sep-13	29-Sep-13	B	Hemiptera, Aphididae	2
53	22-Sep-13	29-Sep-13	B	Diptera	2
53	22-Sep-13	29-Sep-13	B	Hymenoptera, Parasitoid	3
54	22-Sep-13	29-Sep-13	A	Coleoptera	1
54	22-Sep-13	29-Sep-13	A	Collembola	1
54	22-Sep-13	29-Sep-13	A	Hemiptera, Cicadellidae	1

Card # (grid)	Placement Date	Collection Date	Side (A/B)	Insect	Rating
54	22-Sep-13	29-Sep-13	A	Coleoptera	1
54	22-Sep-13	29-Sep-13	A	Hemiptera, Cicadellidae	1
54	22-Sep-13	29-Sep-13	A	Hemiptera, Aphididae	1
54	22-Sep-13	29-Sep-13	A	Hymenoptera, Parasitoid	2
54	22-Sep-13	29-Sep-13	A	Diptera	3
54	22-Sep-13	29-Sep-13	A	Hymenoptera, Parasitoid	3
54	22-Sep-13	29-Sep-13	B	Hemiptera, Cicadellidae	1
54	22-Sep-13	29-Sep-13	B	Slug (Class: Gastropoda)	1
54	22-Sep-13	29-Sep-13	B	Coleoptera	1
54	22-Sep-13	29-Sep-13	B	Thrips (Order: Thysanoptera)	1
54	22-Sep-13	29-Sep-13	B	Hemiptera, Aphididae	1
54	22-Sep-13	29-Sep-13	B	Hemiptera, Aphididae	1
54	22-Sep-13	29-Sep-13	B	Coleoptera	1
54	22-Sep-13	29-Sep-13	B	Diptera	2
54	22-Sep-13	29-Sep-13	B	Hymenoptera, Parasitoid	2
54	22-Sep-13	29-Sep-13	B	Diptera	2
54	22-Sep-13	29-Sep-13	B	Hymenoptera, Parasitoid	3
55	22-Sep-13	29-Sep-13	A	Coleoptera	1
55	22-Sep-13	29-Sep-13	A	Hemiptera, Cicadellidae	2
55	22-Sep-13	29-Sep-13	A	Hymenoptera, Parasitoid	2
55	22-Sep-13	29-Sep-13	B	Coleoptera	1
55	22-Sep-13	29-Sep-13	B	Hemiptera, Aphididae	1
55	22-Sep-13	29-Sep-13	B	Diptera	2
55	22-Sep-13	29-Sep-13	B	Hymenoptera, Parasitoid	3
56	22-Sep-13	29-Sep-13	A	Coleoptera	1
56	22-Sep-13	29-Sep-13	A	Collembola	1
56	22-Sep-13	29-Sep-13	A	Hemiptera, Aphididae	1
56	22-Sep-13	29-Sep-13	A	Hemiptera, Cicadellidae	2
56	22-Sep-13	29-Sep-13	A	Diptera	2
56	22-Sep-13	29-Sep-13	A	Hymenoptera, Parasitoid	3
56	22-Sep-13	29-Sep-13	B	Arachnida, Araneae	1

Card # (grid)	Placement Date	Collection Date	Side (A/B)	Insect	Rating
56	22-Sep-13	29-Sep-13	B	Coleoptera	1
56	22-Sep-13	29-Sep-13	B	Diptera	2
56	22-Sep-13	29-Sep-13	B	Hemiptera, Cicadellidae	2
56	22-Sep-13	29-Sep-13	B	Hemiptera, Aphididae	2
56	22-Sep-13	29-Sep-13	B	Hymenoptera, Parasitoid	3
57	22-Sep-13	29-Sep-13	A	None observed	0
57	22-Sep-13	29-Sep-13	A	Hymenoptera, Parasitoid	1
57	22-Sep-13	29-Sep-13	A	Hymenoptera, Parasitoid	1
57	22-Sep-13	29-Sep-13	A	Diptera, Culicidae	1
57	22-Sep-13	29-Sep-13	A	Hymenoptera, Parasitoid	1
57	22-Sep-13	29-Sep-13	A	Diptera, Culicidae	1
57	22-Sep-13	29-Sep-13	A	Hymenoptera, Parasitoid	1
57	22-Sep-13	29-Sep-13	A	Diptera, Simuliidae	1
57	22-Sep-13	29-Sep-13	A	Hymenoptera, Parasitoid	1
57	22-Sep-13	29-Sep-13	A	Hymenoptera, Parasitoid	1
57	22-Sep-13	29-Sep-13	A	Hemiptera, Aphididae	1
57	22-Sep-13	29-Sep-13	A	Hymenoptera, Parasitoid	1
57	22-Sep-13	29-Sep-13	A	Hymenoptera, Parasitoid	1
57	22-Sep-13	29-Sep-13	A	Diptera, Simuliidae	1
57	22-Sep-13	29-Sep-13	A	Hemiptera, Cicadellidae, Macrosteles	1
57	22-Sep-13	29-Sep-13	A	Hymenoptera, Parasitoid	1
57	22-Sep-13	29-Sep-13	A	Diptera, Culicidae	1
57	22-Sep-13	29-Sep-13	A	Hymenoptera, Parasitoid	1
57	22-Sep-13	29-Sep-13	A	Diptera, Simuliidae	1
57	22-Sep-13	29-Sep-13	A	Hymenoptera, Parasitoid	1
57	22-Sep-13	29-Sep-13	A	Hemiptera, Aphididae	1
57	22-Sep-13	29-Sep-13	A	Hymenoptera, Parasitoid	1

Card # (grid)	Placement Date	Collection Date	Side (A/B)	Insect	Rating
57	22-Sep-13	29-Sep-13	A	Diptera, unknown (1)	1
57	22-Sep-13	29-Sep-13	A	Coleoptera, Coccinellidae	1
57	22-Sep-13	29-Sep-13	A	Hymenoptera, Parasitoid	1
57	22-Sep-13	29-Sep-13	A	Hymenoptera, Parasitoid	1
57	22-Sep-13	29-Sep-13	A	Diptera, Simuliidae	1
57	22-Sep-13	29-Sep-13	A	Hemiptera, Cicadellidae, Typhlocybinae	1
57	22-Sep-13	29-Sep-13	A	Hymenoptera, Parasitoid	1
57	22-Sep-13	29-Sep-13	A	Diptera, Simuliidae	1
57	22-Sep-13	29-Sep-13	A	Hymenoptera, Parasitoid	1
57	22-Sep-13	29-Sep-13	A	Hemiptera, Cicadellidae, Typhlocybinae	1
57	22-Sep-13	29-Sep-13	A	Coleoptera, unknown (shiny black)	1
57	22-Sep-13	29-Sep-13	A	Hymenoptera, Parasitoid	1
57	22-Sep-13	29-Sep-13	A	Diptera, Culicidae	1
57	22-Sep-13	29-Sep-13	A	Diptera, Simuliidae	1
57	22-Sep-13	29-Sep-13	A	Hymenoptera, Parasitoid	1
57	22-Sep-13	29-Sep-13	A	Hemiptera, Cicadellidae, (green- damaged)	1
57	22-Sep-13	29-Sep-13	A	Hymenoptera, Parasitoid	1
57	22-Sep-13	29-Sep-13	A	Diptera, Culicidae	1
57	22-Sep-13	29-Sep-13	A	Diptera, Simuliidae	1
57	22-Sep-13	29-Sep-13	A	Diptera, Simuliidae	1
57	22-Sep-13	29-Sep-13	A	Hymenoptera, Parasitoid	1
57	22-Sep-13	29-Sep-13	A	Hemiptera, Cicadellidae, Macrosteles	1
57	22-Sep-13	29-Sep-13	A	Hymenoptera, Parasitoid	1

Card # (grid)	Placement Date	Collection Date	Side (A/B)	Insect	Rating
57	22-Sep-13	29-Sep-13	A	Diptera, Culicidae	1
57	22-Sep-13	29-Sep-13	B	None observed	0
57	22-Sep-13	29-Sep-13	B	Hemiptera, Cicadellidae, Macrosteles	1
57	22-Sep-13	29-Sep-13	B	Hymenoptera, Parasitoid	1
57	22-Sep-13	29-Sep-13	B	Hymenoptera, Parasitoid	1
57	22-Sep-13	29-Sep-13	B	Hemiptera, Aphididae	1
57	22-Sep-13	29-Sep-13	B	Diptera, Culicidae	1
57	22-Sep-13	29-Sep-13	B	Hymenoptera, Parasitoid	1
57	22-Sep-13	29-Sep-13	B	Hemiptera, Aphididae	1
57	22-Sep-13	29-Sep-13	B	Coleoptera (ladybeetle- type)	1
57	22-Sep-13	29-Sep-13	B	Coleoptera (ladybeetle- type)	1
57	22-Sep-13	29-Sep-13	B	Hymenoptera, Parasitoid	1
57	22-Sep-13	29-Sep-13	B	Hemiptera, Aphididae	1
57	22-Sep-13	29-Sep-13	B	Diptera, Simuliidae	1
57	22-Sep-13	29-Sep-13	B	Hemiptera, Cicadellidae, Typhlocybinae	1
57	22-Sep-13	29-Sep-13	B	Coleoptera, unknown (ladybeetle-type, blk)	1
57	22-Sep-13	29-Sep-13	B	Diptera, unknown (1)	1
57	22-Sep-13	29-Sep-13	B	Hymenoptera, Parasitoid	1
57	22-Sep-13	29-Sep-13	B	Hymenoptera, Parasitoid	1
57	22-Sep-13	29-Sep-13	B	Diptera, Simuliidae	1
57	22-Sep-13	29-Sep-13	B	Hemiptera, Cicadellidae, Macrosteles	1
57	22-Sep-13	29-Sep-13	B	Hymenoptera, Parasitoid	1
57	22-Sep-13	29-Sep-13	B	Coleoptera (ladybeetle- type)	1

Card # (grid)	Placement Date	Collection Date	Side (A/B)	Insect	Rating
57	22-Sep-13	29-Sep-13	B	Hymenoptera, Parasitoid	1
57	22-Sep-13	29-Sep-13	B	Hymenoptera, Parasitoid	1
57	22-Sep-13	29-Sep-13	B	Diptera, Chironomidae	1
57	22-Sep-13	29-Sep-13	B	Hemiptera, Aphididae	1
57	22-Sep-13	29-Sep-13	B	Hymenoptera, Parasitoid	1
57	22-Sep-13	29-Sep-13	B	Hemiptera, Aphididae	1
57	22-Sep-13	29-Sep-13	B	Hymenoptera, Parasitoid	1
57	22-Sep-13	29-Sep-13	B	Hemiptera, Aphididae	1
57	22-Sep-13	29-Sep-13	B	Hymenoptera, Parasitoid	1
57	22-Sep-13	29-Sep-13	B	Hemiptera, Aphididae	1
57	22-Sep-13	29-Sep-13	B	Hemiptera, Aphididae	1
57	22-Sep-13	29-Sep-13	B	Hymenoptera, Parasitoid	1
57	22-Sep-13	29-Sep-13	B	Hemiptera, Cicadellidae, Macrosteles	1
57	22-Sep-13	29-Sep-13	B	Coleoptera, Coccinellidae	1
57	22-Sep-13	29-Sep-13	B	Hymenoptera, Parasitoid	1
57	22-Sep-13	29-Sep-13	B	Hymenoptera, Parasitoid	1
57	22-Sep-13	29-Sep-13	B	Hemiptera, Aphididae	1
57	22-Sep-13	29-Sep-13	B	Coleoptera, Coccinellidae	1
57	22-Sep-13	29-Sep-13	B	Hymenoptera, Parasitoid	1
57	22-Sep-13	29-Sep-13	B	Hemiptera, Aphididae	1
57	22-Sep-13	29-Sep-13	B	Hemiptera, Cicadellidae, Typhlocybinae	1
57	22-Sep-13	29-Sep-13	B	Hymenoptera, Parasitoid	1
57	22-Sep-13	29-Sep-13	B	Hemiptera, Aphididae	1
57	22-Sep-13	29-Sep-13	B	Hymenoptera, Parasitoid	1
57	22-Sep-13	29-Sep-13	B	Hemiptera, Aphididae	1

Card # (grid)	Placement Date	Collection Date	Side (A/B)	Insect	Rating
57	22-Sep-13	29-Sep-13	B	Diptera, Simuliidae	1
57	22-Sep-13	29-Sep-13	B	Hymenoptera, Parasitoid	1
57	22-Sep-13	29-Sep-13	B	Hymenoptera, Parasitoid	1
57	22-Sep-13	29-Sep-13	B	Hemiptera, Aphididae	1
57	22-Sep-13	29-Sep-13	B	Hemiptera, Cicadellidae, Macrosteles	1
57	22-Sep-13	29-Sep-13	B	Hymenoptera, Parasitoid	1
57	22-Sep-13	29-Sep-13	B	Hemiptera, Aphididae	1
57	22-Sep-13	29-Sep-13	B	Hymenoptera, Parasitoid	1
57	22-Sep-13	29-Sep-13	B	Hemiptera, Aphididae	1
58	22-Sep-13	29-Sep-13	A	Coleoptera	1
58	22-Sep-13	29-Sep-13	A	Hemiptera, Aphididae	1
58	22-Sep-13	29-Sep-13	A	Diptera	2
58	22-Sep-13	29-Sep-13	A	Hemiptera, Cicadellidae	2
58	22-Sep-13	29-Sep-13	A	Hymenoptera, Parasitoid	3
58	22-Sep-13	29-Sep-13	B	Diptera	1
58	22-Sep-13	29-Sep-13	B	Coleoptera	1
58	22-Sep-13	29-Sep-13	B	Hemiptera, Cicadellidae	1
58	22-Sep-13	29-Sep-13	B	Arachnida, Araneae	1
58	22-Sep-13	29-Sep-13	B	Hymenoptera, Parasitoid	2
60	22-Sep-13	29-Sep-13	A	Arachnida, Araneae	1
60	22-Sep-13	29-Sep-13	A	Hemiptera, Aphididae	2
60	22-Sep-13	29-Sep-13	A	Hemiptera, Cicadellidae	2
60	22-Sep-13	29-Sep-13	A	Diptera	3
60	22-Sep-13	29-Sep-13	A	Hymenoptera, Parasitoid	3
60	22-Sep-13	29-Sep-13	B	Hemiptera, Cicadellidae	1
60	22-Sep-13	29-Sep-13	B	Coleoptera	1
60	22-Sep-13	29-Sep-13	B	Hemiptera, Aphididae	2
60	22-Sep-13	29-Sep-13	B	Diptera	2
60	22-Sep-13	29-Sep-13	B	Hymenoptera, Parasitoid	3
61	22-Sep-13	29-Sep-13	A	None observed	0

Card # (grid)	Placement Date	Collection Date	Side (A/B)	Insect	Rating
61	22-Sep-13	29-Sep-13	A	None observed	0
61	22-Sep-13	29-Sep-13	A	None observed	0
61	22-Sep-13	29-Sep-13	A	None observed	0
61	22-Sep-13	29-Sep-13	A	None observed	0
61	22-Sep-13	29-Sep-13	A	None observed	0
61	22-Sep-13	29-Sep-13	A	Hymenoptera, Parasitoid	1
61	22-Sep-13	29-Sep-13	A	Unknown	1
61	22-Sep-13	29-Sep-13	A	Unknown (same as 1B)	1
61	22-Sep-13	29-Sep-13	A	Hymenoptera, Parasitoid	1
61	22-Sep-13	29-Sep-13	A	Hymenoptera, Parasitoid	1
61	22-Sep-13	29-Sep-13	A	Hymenoptera, Parasitoid	1
61	22-Sep-13	29-Sep-13	A	Diptera, Simuliidae	1
61	22-Sep-13	29-Sep-13	A	Hymenoptera, Parasitoid	1
61	22-Sep-13	29-Sep-13	A	Unknown	1
61	22-Sep-13	29-Sep-13	A	Diptera, Simuliidae	1
61	22-Sep-13	29-Sep-13	A	Hymenoptera, Parasitoid	1
61	22-Sep-13	29-Sep-13	A	Hymenoptera, Parasitoid	1
61	22-Sep-13	29-Sep-13	A	Hymenoptera, Parasitoid	1
61	22-Sep-13	29-Sep-13	A	Hymenoptera, Parasitoid	1
61	22-Sep-13	29-Sep-13	A	Hemiptera, Cicadellidae, Typhlocybinae	1
61	22-Sep-13	29-Sep-13	A	Chironomidae	1
61	22-Sep-13	29-Sep-13	A	Hymenoptera, Parasitoid	1
61	22-Sep-13	29-Sep-13	A	Hymenoptera, Parasitoid	1
61	22-Sep-13	29-Sep-13	A	Hemiptera, Cicadellidae, Typhlocybinae	1
61	22-Sep-13	29-Sep-13	A	Chironomidae	1
61	22-Sep-13	29-Sep-13	A	Hymenoptera, Parasitoid	1

Card # (grid)	Placement Date	Collection Date	Side (A/B)	Insect	Rating
61	22-Sep-13	29-Sep-13	A	Diptera, Simuliidae	1
61	22-Sep-13	29-Sep-13	A	Coleoptera	1
61	22-Sep-13	29-Sep-13	A	Hymenoptera, Parasitoid	1
61	22-Sep-13	29-Sep-13	A	Hymenoptera, Parasitoid	1
61	22-Sep-13	29-Sep-13	A	Diptera, Nematocera	1
61	22-Sep-13	29-Sep-13	A	Hymenoptera, Parasitoid	1
61	22-Sep-13	29-Sep-13	A	Hymenoptera, Parasitoid	2
61	22-Sep-13	29-Sep-13	B	None observed	0
61	22-Sep-13	29-Sep-13	B	Hymenoptera, Parasitoid	1
61	22-Sep-13	29-Sep-13	B	Hymenoptera, Parasitoid	1
61	22-Sep-13	29-Sep-13	B	Hymenoptera, Parasitoid	1
61	22-Sep-13	29-Sep-13	B	Uknown, aphid?	1
61	22-Sep-13	29-Sep-13	B	Hymenoptera, Parasitoid	1
61	22-Sep-13	29-Sep-13	B	Hymenoptera, Parasitoid	1
61	22-Sep-13	29-Sep-13	B	Arachnida, Araneae	1
61	22-Sep-13	29-Sep-13	B	Hymenoptera, Parasitoid	1
61	22-Sep-13	29-Sep-13	B	Diptera, Nematocera, Cecidomyiidae	1
61	22-Sep-13	29-Sep-13	B	Hymenoptera, Parasitoid	1
61	22-Sep-13	29-Sep-13	B	Diptera, Simuliidae	1
61	22-Sep-13	29-Sep-13	B	Diptera, Nematocera	1
61	22-Sep-13	29-Sep-13	B	Diptera, Simuliidae	1
61	22-Sep-13	29-Sep-13	B	Hymenoptera, Parasitoid	1
61	22-Sep-13	29-Sep-13	B	Hymenoptera, Parasitoid	1
61	22-Sep-13	29-Sep-13	B	Diptera, Simuliidae	1
61	22-Sep-13	29-Sep-13	B	Hemiptera, Cicadellidae, Macrosteles	1

Card # (grid)	Placement Date	Collection Date	Side (A/B)	Insect	Rating
61	22-Sep-13	29-Sep-13	B	Hymenoptera, Parasitoid	1
61	22-Sep-13	29-Sep-13	B	Chironomidae	1
61	22-Sep-13	29-Sep-13	B	Hymenoptera, Parasitoid	1
61	22-Sep-13	29-Sep-13	B	Hemiptera, Cicadellidae, Typhlocybinae	1
61	22-Sep-13	29-Sep-13	B	Hymenoptera, Parasitoid	1
61	22-Sep-13	29-Sep-13	B	Coleoptera	1
61	22-Sep-13	29-Sep-13	B	Hymenoptera, Parasitoid	1
61	22-Sep-13	29-Sep-13	B	Hymenoptera, Parasitoid	1
61	22-Sep-13	29-Sep-13	B	Hymenoptera, Parasitoid	1
61	22-Sep-13	29-Sep-13	B	Hemiptera, Cicadellidae, Typhlocybinae	1
61	22-Sep-13	29-Sep-13	B	Hymenoptera, Parasitoid	1
61	22-Sep-13	29-Sep-13	B	Unknown	1
61	22-Sep-13	29-Sep-13	B	Hymenoptera, Parasitoid	1
61	22-Sep-13	29-Sep-13	B	Hymenoptera, Parasitoid	1
61	22-Sep-13	29-Sep-13	B	Diptera unknown	1
61	22-Sep-13	29-Sep-13	B	Hymenoptera, Parasitoid	2
61	22-Sep-13	29-Sep-13	B	Hymenoptera, Parasitoid	2
61	22-Sep-13	29-Sep-13	B	Hymenoptera, Parasitoid	2
61	22-Sep-13	29-Sep-13	B	Hymenoptera, Parasitoid	2
64	22-Sep-13	29-Sep-13	A	Coleoptera	1
64	22-Sep-13	29-Sep-13	A	Arachnida, Araneae	1
64	22-Sep-13	29-Sep-13	A	Slug (Class: Gastropoda)	1
64	22-Sep-13	29-Sep-13	A	Hemiptera, Cicadellidae	1
64	22-Sep-13	29-Sep-13	A	Diptera	2

Card # (grid)	Placement Date	Collection Date	Side (A/B)	Insect	Rating
64	22-Sep-13	29-Sep-13	A	Hymenoptera, Parasitoid	3
64	22-Sep-13	29-Sep-13	B	Hemiptera, Cicadellidae	1
64	22-Sep-13	29-Sep-13	B	Diptera	1
64	22-Sep-13	29-Sep-13	B	Coleoptera	1
64	22-Sep-13	29-Sep-13	B	Hymenoptera, Parasitoid	2
65	22-Sep-13	29-Sep-13	A	Hemiptera, Aphididae	1
65	22-Sep-13	29-Sep-13	A	Diptera	1
65	22-Sep-13	29-Sep-13	A	Hymenoptera, Parasitoid	1
65	22-Sep-13	29-Sep-13	A	Coleoptera	1
65	22-Sep-13	29-Sep-13	B	Coleoptera	1
65	22-Sep-13	29-Sep-13	B	Diptera	1
65	22-Sep-13	29-Sep-13	B	Hymenoptera, Parasitoid	3
70	22-Sep-13	29-Sep-13	A	Arachnida, Araneae	1
70	22-Sep-13	29-Sep-13	A	Coleoptera	2
70	22-Sep-13	29-Sep-13	A	Hymenoptera, Formicidae	2
70	22-Sep-13	29-Sep-13	A	Diptera	3
70	22-Sep-13	29-Sep-13	A	Hymenoptera, Parasitoid	3
70	22-Sep-13	29-Sep-13	B	unknown	1
70	22-Sep-13	29-Sep-13	B	Slug (Class: Gastropoda)	1
70	22-Sep-13	29-Sep-13	B	Hemiptera, Aphididae	1
70	22-Sep-13	29-Sep-13	B	Hymenoptera, Parasitoid	2
71	22-Sep-13	29-Sep-13	A	Diptera	1
71	22-Sep-13	29-Sep-13	A	Hemiptera, Cicadellidae	1
71	22-Sep-13	29-Sep-13	A	Hemiptera, Aphididae	1
71	22-Sep-13	29-Sep-13	A	Hymenoptera, Parasitoid	3
71	22-Sep-13	29-Sep-13	B	Hemiptera, Cicadellidae	1
71	22-Sep-13	29-Sep-13	B	Collembola	1
71	22-Sep-13	29-Sep-13	B	Hemiptera, Aphididae	1
71	22-Sep-13	29-Sep-13	B	Coleoptera	1
71	22-Sep-13	29-Sep-13	B	Diptera	2

Card # (grid)	Placement Date	Collection Date	Side (A/B)	Insect	Rating
71	22-Sep-13	29-Sep-13	B	Hymenoptera, Parasitoid	3
72	22-Sep-13	29-Sep-13	A	Hemiptera, Cicadellidae	1
72	22-Sep-13	29-Sep-13	A	Coleoptera	1
72	22-Sep-13	29-Sep-13	A	Hemiptera, Aphididae	1
72	22-Sep-13	29-Sep-13	A	Diptera	2
72	22-Sep-13	29-Sep-13	A	Hymenoptera, Parasitoid	3
72	22-Sep-13	29-Sep-13	B	Coleoptera	1
72	22-Sep-13	29-Sep-13	B	Hemiptera, Cicadellidae	1
72	22-Sep-13	29-Sep-13	B	Arachnida, Araneae	1
72	22-Sep-13	29-Sep-13	B	Hemiptera, Aphididae	2
72	22-Sep-13	29-Sep-13	B	Diptera	2
72	22-Sep-13	29-Sep-13	B	Hymenoptera, Parasitoid	3
73	22-Sep-13	29-Sep-13	A	Hemiptera, Cicadellidae, Typhlocybiniae	1
73	22-Sep-13	29-Sep-13	A	Coleoptera	1
73	22-Sep-13	29-Sep-13	A	Hemiptera, Aphididae	1
73	22-Sep-13	29-Sep-13	A	Hymenoptera, Parasitoid	3
73	22-Sep-13	29-Sep-13	A	Diptera	3
73	22-Sep-13	29-Sep-13	B	Coleoptera	1
73	22-Sep-13	29-Sep-13	B	Hemiptera, Aphididae	2
73	22-Sep-13	29-Sep-13	B	Hymenoptera, Parasitoid	3
73	22-Sep-13	29-Sep-13	B	Diptera	3
74	22-Sep-13	29-Sep-13	A	None observed	0
74	22-Sep-13	29-Sep-13	A	Hymenoptera, Formicidae	1
74	22-Sep-13	29-Sep-13	A	Diptera, Simuliidae	1
74	22-Sep-13	29-Sep-13	A	Hymenoptera, Parasitoid	1
74	22-Sep-13	29-Sep-13	A	Hymenoptera, Formicidae	1
74	22-Sep-13	29-Sep-13	A	Hemiptera, Aphididae	1
74	22-Sep-13	29-Sep-13	A	Diptera, unknown	1
74	22-Sep-13	29-Sep-13	A	Diptera, Nematocera	1
74	22-Sep-13	29-Sep-13	A	Diptera, Simuliidae	1

Card # (grid)	Placement Date	Collection Date	Side (A/B)	Insect	Rating
74	22-Sep-13	29-Sep-13	A	Hymenoptera, Formicidae	1
74	22-Sep-13	29-Sep-13	A	Diptera, Culicidae	1
74	22-Sep-13	29-Sep-13	A	Hemiptera, Cicadellidae, Macrosteles	1
74	22-Sep-13	29-Sep-13	A	Hymenoptera, Parasitoid	1
74	22-Sep-13	29-Sep-13	A	Coleoptera, Coccinellidae	1
74	22-Sep-13	29-Sep-13	A	Hymenoptera, Parasitoid	1
74	22-Sep-13	29-Sep-13	A	Hymenoptera, Formicidae	1
74	22-Sep-13	29-Sep-13	A	Hymenoptera, unknown	1
74	22-Sep-13	29-Sep-13	A	Hymenoptera, Parasitoid	1
74	22-Sep-13	29-Sep-13	A	Hymenoptera, Parasitoid	1
74	22-Sep-13	29-Sep-13	A	Hymenoptera, Parasitoid	1
74	22-Sep-13	29-Sep-13	A	Diptera, unknown	1
74	22-Sep-13	29-Sep-13	A	Hemiptera, Cicadellidae, Typhlocybinae	1
74	22-Sep-13	29-Sep-13	A	Hemiptera, Cicadellidae, Macrosteles	1
74	22-Sep-13	29-Sep-13	A	Hymenoptera, Formicidae	1
74	22-Sep-13	29-Sep-13	A	Hemiptera, Aphididae	1
74	22-Sep-13	29-Sep-13	A	Hymenoptera, Formicidae	1
74	22-Sep-13	29-Sep-13	A	Hymenoptera, Parasitoid	1
74	22-Sep-13	29-Sep-13	A	Arachnida, Araneae	1
74	22-Sep-13	29-Sep-13	A	Diptera, Culicidae	1
74	22-Sep-13	29-Sep-13	A	Coleoptera, unknown (shiny black)	1
74	22-Sep-13	29-Sep-13	A	Hymenoptera, Parasitoid	1

Card # (grid)	Placement Date	Collection Date	Side (A/B)	Insect	Rating
74	22-Sep-13	29-Sep-13	A	Isotomidae (Collembola)	1
74	22-Sep-13	29-Sep-13	A	Hymenoptera, Parasitoid	1
74	22-Sep-13	29-Sep-13	A	Hymenoptera, Parasitoid	1
74	22-Sep-13	29-Sep-13	A	Hymenoptera, Formicidae	1
74	22-Sep-13	29-Sep-13	A	Diptera, unknown (1)	1
74	22-Sep-13	29-Sep-13	A	Diptera, unknown	1
74	22-Sep-13	29-Sep-13	A	Hemiptera, Cicadellidae, Typhlocybiniae	1
74	22-Sep-13	29-Sep-13	A	Hymenoptera, Parasitoid	1
74	22-Sep-13	29-Sep-13	A	Diptera, unknown	1
74	22-Sep-13	29-Sep-13	A	Hymenoptera, Formicidae	1
74	22-Sep-13	29-Sep-13	A	Coleoptera (ladybeetle- type)	1
74	22-Sep-13	29-Sep-13	A	Diptera, Unknown (1)	1
74	22-Sep-13	29-Sep-13	A	Hymenoptera, Parasitoid	1
74	22-Sep-13	29-Sep-13	A	Diptera, Nematocera	1
74	22-Sep-13	29-Sep-13	A	Coleoptera, Coccinellidae	1
74	22-Sep-13	29-Sep-13	A	Diptera, Nematocera	1
74	22-Sep-13	29-Sep-13	A	Hemiptera, Cicadellidae, Macrosteles	1
74	22-Sep-13	29-Sep-13	A	Diptera, unknown (1)	1
74	22-Sep-13	29-Sep-13	A	Diptera, Culicidae	1
74	22-Sep-13	29-Sep-13	A	Hymenoptera, Parasitoid	1
74	22-Sep-13	29-Sep-13	A	Arachnida, Araneae	1
74	22-Sep-13	29-Sep-13	B	None observed	0
74	22-Sep-13	29-Sep-13	B	Coleoptera, Coccinellidae	1
74	22-Sep-13	29-Sep-13	B	Diptera, Nematocera	1
74	22-Sep-13	29-Sep-13	B	Hymenoptera, Parasitoid	1

Card # (grid)	Placement Date	Collection Date	Side (A/B)	Insect	Rating
74	22-Sep-13	29-Sep-13	B	Hemiptera, Aphididae	1
74	22-Sep-13	29-Sep-13	B	Diptera, Nematocera	1
74	22-Sep-13	29-Sep-13	B	Hymenoptera, Formicidae	1
74	22-Sep-13	29-Sep-13	B	Coleoptera (ladybeetle- type)	1
74	22-Sep-13	29-Sep-13	B	Hymenoptera, Parasitoid	1
74	22-Sep-13	29-Sep-13	B	Hemiptera, Aphididae	1
74	22-Sep-13	29-Sep-13	B	Diptera, Nematocera	1
74	22-Sep-13	29-Sep-13	B	Coleoptera (tiny, black, round)	1
74	22-Sep-13	29-Sep-13	B	Hymenoptera, Formicidae	1
74	22-Sep-13	29-Sep-13	B	Hymenoptera, Formicidae	1
74	22-Sep-13	29-Sep-13	B	Diptera, Simuliidae	1
74	22-Sep-13	29-Sep-13	B	Hymenoptera, Formicidae	1
74	22-Sep-13	29-Sep-13	B	Hymenoptera, Parasitoid	1
74	22-Sep-13	29-Sep-13	B	Hymenoptera, Parasitoid	1
74	22-Sep-13	29-Sep-13	B	Hemiptera, Aphididae	1
74	22-Sep-13	29-Sep-13	B	Unknown - damaged	1
74	22-Sep-13	29-Sep-13	B	Hemiptera, Cicadellidae, Typhlocybinae	1
74	22-Sep-13	29-Sep-13	B	Hymenoptera, Formicidae	1
74	22-Sep-13	29-Sep-13	B	Hymenoptera, Parasitoid	1
74	22-Sep-13	29-Sep-13	B	Hemiptera, Aphididae	1
74	22-Sep-13	29-Sep-13	B	Hymenoptera, Formicidae	1
74	22-Sep-13	29-Sep-13	B	Coleoptera, Coccinellidae	1
74	22-Sep-13	29-Sep-13	B	Diptera, Simuliidae	1
74	22-Sep-13	29-Sep-13	B	Hymenoptera, Formicidae	1

Card # (grid)	Placement Date	Collection Date	Side (A/B)	Insect	Rating
74	22-Sep-13	29-Sep-13	B	Hymenoptera, Formicidae	1
74	22-Sep-13	29-Sep-13	B	Hymenoptera, Parasitoid	1
74	22-Sep-13	29-Sep-13	B	Coleoptera, unknown (shiny black)	1
74	22-Sep-13	29-Sep-13	B	Hymenoptera, Parasitoid	1
74	22-Sep-13	29-Sep-13	B	Hemiptera, Aphididae	1
74	22-Sep-13	29-Sep-13	B	Diptera, Nematocera	1
74	22-Sep-13	29-Sep-13	B	Diptera, Simuliidae	1
74	22-Sep-13	29-Sep-13	B	Hymenoptera, Parasitoid	1
74	22-Sep-13	29-Sep-13	B	Hymenoptera, Parasitoid	1
74	22-Sep-13	29-Sep-13	B	Coleoptera, unknown (shiny black)	1
74	22-Sep-13	29-Sep-13	B	Hymenoptera, Parasitoid	1
74	22-Sep-13	29-Sep-13	B	Diptera, Simuliidae	1
74	22-Sep-13	29-Sep-13	B	Hymenoptera, Parasitoid	1
74	22-Sep-13	29-Sep-13	B	Hemiptera, Aphididae	1
74	22-Sep-13	29-Sep-13	B	Arachnida, Araneae	1
74	22-Sep-13	29-Sep-13	B	Hymenoptera, Parasitoid	1
74	22-Sep-13	29-Sep-13	B	Hymenoptera, Formicidae	1
74	22-Sep-13	29-Sep-13	B	Hymenoptera, Parasitoid	1
74	22-Sep-13	29-Sep-13	B	Hymenoptera, Formicidae	1
74	22-Sep-13	29-Sep-13	B	Hemiptera, Aphididae	1
74	22-Sep-13	29-Sep-13	B	Hemiptera, Cicadellidae, Macrosteles	1
74	22-Sep-13	29-Sep-13	B	Diptera, Nematocera	1
74	22-Sep-13	29-Sep-13	B	Hymenoptera, Formicidae	1
74	22-Sep-13	29-Sep-13	B	Diptera, Nematocera	1

Card # (grid)	Placement Date	Collection Date	Side (A/B)	Insect	Rating
74	22-Sep-13	29-Sep-13	B	Hymenoptera, Parasitoid	1
75	22-Sep-13	29-Sep-13	A	None observed	0
75	22-Sep-13	29-Sep-13	A	None observed	0
75	22-Sep-13	29-Sep-13	A	None observed	0
75	22-Sep-13	29-Sep-13	A	None observed	0
75	22-Sep-13	29-Sep-13	A	None observed	0
75	22-Sep-13	29-Sep-13	A	None observed	0
75	22-Sep-13	29-Sep-13	A	None observed	0
75	22-Sep-13	29-Sep-13	A	None observed	0
75	22-Sep-13	29-Sep-13	A	None observed	0
75	22-Sep-13	29-Sep-13	A	None observed	0
75	22-Sep-13	29-Sep-13	A	None observed	0
75	22-Sep-13	29-Sep-13	A	None observed	0
75	22-Sep-13	29-Sep-13	A	None observed	0
75	22-Sep-13	29-Sep-13	A	Hymenoptera, Parasitoid	1
75	22-Sep-13	29-Sep-13	A	Hemiptera, Aphididae	1
75	22-Sep-13	29-Sep-13	A	Hymenoptera, Parasitoid	1
75	22-Sep-13	29-Sep-13	A	Collembola, Isotomidae	1
75	22-Sep-13	29-Sep-13	A	Hymenoptera, Parasitoid	1
75	22-Sep-13	29-Sep-13	A	Isotomidae (Collembola)	1
75	22-Sep-13	29-Sep-13	A	Diptera, Simuliidae	1
75	22-Sep-13	29-Sep-13	A	Hymenoptera, Parasitoid	1
75	22-Sep-13	29-Sep-13	A	Hymenoptera, Parasitoid	1
75	22-Sep-13	29-Sep-13	A	Hymenoptera, Parasitoid	1
75	22-Sep-13	29-Sep-13	A	Hymenoptera, Parasitoid	1
75	22-Sep-13	29-Sep-13	A	Hymenoptera, Parasitoid	1
75	22-Sep-13	29-Sep-13	A	Hymenoptera, Parasitoid	1
75	22-Sep-13	29-Sep-13	B	None observed	0

Card # (grid)	Placement Date	Collection Date	Side (A/B)	Insect	Rating
75	22-Sep-13	29-Sep-13	B	Hymenoptera, Parasitoid	1
75	22-Sep-13	29-Sep-13	B	Hymenoptera, Formicidae	1
75	22-Sep-13	29-Sep-13	B	Hymenoptera, Parasitoid	1
75	22-Sep-13	29-Sep-13	B	Hymenoptera, Formicidae	1
75	22-Sep-13	29-Sep-13	B	Hymenoptera, Parasitoid	1
75	22-Sep-13	29-Sep-13	B	Hymenoptera, Formicidae	1
75	22-Sep-13	29-Sep-13	B	Collembola, Isotomidae	1
75	22-Sep-13	29-Sep-13	B	Hymenoptera, Formicidae	1
75	22-Sep-13	29-Sep-13	B	Hymenoptera, Parasitoid	1
75	22-Sep-13	29-Sep-13	B	Diptera, Simuliidae	1
75	22-Sep-13	29-Sep-13	B	Hymenoptera, Formicidae	1
75	22-Sep-13	29-Sep-13	B	Hymenoptera, Parasitoid	1
75	22-Sep-13	29-Sep-13	B	Diptera, unknown (1)	1
75	22-Sep-13	29-Sep-13	B	Hymenoptera, Formicidae	1
75	22-Sep-13	29-Sep-13	B	Hymenoptera, Formicidae	1
75	22-Sep-13	29-Sep-13	B	Hymenoptera, Parasitoid	1
75	22-Sep-13	29-Sep-13	B	Coleoptera, unknown (red/black)	1
75	22-Sep-13	29-Sep-13	B	Coleoptera, unknown (shiny black)	1
75	22-Sep-13	29-Sep-13	B	Hymenoptera, Formicidae	1
75	22-Sep-13	29-Sep-13	B	Hymenoptera, Parasitoid	1
75	22-Sep-13	29-Sep-13	B	Hymenoptera, Formicidae	1

Card # (grid)	Placement Date	Collection Date	Side (A/B)	Insect	Rating
75	22-Sep-13	29-Sep-13	B	Hymenoptera, Parasitoid	1
75	22-Sep-13	29-Sep-13	B	Hymenoptera, Parasitoid	1
75	22-Sep-13	29-Sep-13	B	Hymenoptera, Parasitoid	1
75	22-Sep-13	29-Sep-13	B	Hymenoptera, Formicidae	1
75	22-Sep-13	29-Sep-13	B	Hymenoptera, Parasitoid	1
75	22-Sep-13	29-Sep-13	B	Hymenoptera, Formicidae	1
75	22-Sep-13	29-Sep-13	B	Hymenoptera, Parasitoid	1
75	22-Sep-13	29-Sep-13	B	Hymenoptera, Formicidae	1
75	22-Sep-13	29-Sep-13	B	Hymenoptera, Parasitoid	1
75	22-Sep-13	29-Sep-13	B	Hymenoptera, Formicidae	1
75	22-Sep-13	29-Sep-13	B	Hemiptera, Cicadellidae, Typhlocybinae	1
75	22-Sep-13	29-Sep-13	B	Arachnida, Araneae	1
75	22-Sep-13	29-Sep-13	B	Hymenoptera, Formicidae	1
75	22-Sep-13	29-Sep-13	B	Hemiptera, Cicadellidae, Typhlocybinae	1
75	22-Sep-13	29-Sep-13	B	Hymenoptera, Formicidae	1
75	22-Sep-13	29-Sep-13	B	Hymenoptera, Parasitoid	1
75	22-Sep-13	29-Sep-13	B	Hymenoptera, Parasitoid	1
75	22-Sep-13	29-Sep-13	B	Diptera, Simuliidae	1
75	22-Sep-13	29-Sep-13	B	Diptera, Culicidae	1
75	22-Sep-13	29-Sep-13	B	Hymenoptera, Parasitoid	1
75	22-Sep-13	29-Sep-13	B	Hymenoptera, Formicidae	1

Card # (grid)	Placement Date	Collection Date	Side (A/B)	Insect	Rating
75	22-Sep-13	29-Sep-13	B	Hymenoptera, Parasitoid	1
75	22-Sep-13	29-Sep-13	B	Diptera, Culicidae	1
75	22-Sep-13	29-Sep-13	B	Coleoptera, unknown (shiny black)	1
75	22-Sep-13	29-Sep-13	B	Hymenoptera, Parasitoid	1
75	22-Sep-13	29-Sep-13	B	Hymenoptera, Formicidae	1
75	22-Sep-13	29-Sep-13	B	Hymenoptera, Parasitoid	2
75	22-Sep-13	29-Sep-13	B	Hymenoptera, Formicidae	2
78	22-Sep-13	29-Sep-13	A	Hemiptera, Cicadellidae	1
78	22-Sep-13	29-Sep-13	A	Coleoptera	1
78	22-Sep-13	29-Sep-13	A	Diptera	3
78	22-Sep-13	29-Sep-13	A	Hymenoptera, Parasitoid	3
78	22-Sep-13	29-Sep-13	B	Hemiptera, Cicadellidae, Typhlocybinae	1
78	22-Sep-13	29-Sep-13	B	Hemiptera, Aphididae	1
78	22-Sep-13	29-Sep-13	B	Diptera	2
78	22-Sep-13	29-Sep-13	B	Hymenoptera, Parasitoid	3
79	22-Sep-13	29-Sep-13	A	Hemiptera, Cicadellidae, Typhlocybinae	1
79	22-Sep-13	29-Sep-13	A	Coleoptera (ladybeetle)	1
79	22-Sep-13	29-Sep-13	A	Arachnida, Araneae	1
79	22-Sep-13	29-Sep-13	A	Hymenoptera, Parasitoid	3
79	22-Sep-13	29-Sep-13	A	Diptera	3
79	22-Sep-13	29-Sep-13	A	Hemiptera, Aphididae	3
79	22-Sep-13	29-Sep-13	B	Coleoptera (ladybeetle)	1
79	22-Sep-13	29-Sep-13	B	Hemiptera, Cicadellidae, Typhlocybinae	1
79	22-Sep-13	29-Sep-13	B	Arachnida, Araneae	1
79	22-Sep-13	29-Sep-13	B	Coleoptera other	2

Card # (grid)	Placement Date	Collection Date	Side (A/B)	Insect	Rating
79	22-Sep-13	29-Sep-13	B	Hymenoptera, Parasitoid	3
79	22-Sep-13	29-Sep-13	B	Diptera	3
79	22-Sep-13	29-Sep-13	B	Hemiptera, Aphididae	3
80	22-Sep-13	29-Sep-13	A	Arachnida, Araneae	1
80	22-Sep-13	29-Sep-13	A	Coleoptera	1
80	22-Sep-13	29-Sep-13	A	Hemiptera	1
80	22-Sep-13	29-Sep-13	A	Diptera	2
80	22-Sep-13	29-Sep-13	A	Hymenoptera, Parasitoid	3
80	22-Sep-13	29-Sep-13	B	Hemiptera, Cicadellidae, Typhlocybiniae	1
80	22-Sep-13	29-Sep-13	B	Hymenoptera, Formicidae	1
80	22-Sep-13	29-Sep-13	B	Unknown	1
80	22-Sep-13	29-Sep-13	B	Diptera	1
80	22-Sep-13	29-Sep-13	B	Hymenoptera, Parasitoid	2
81	22-Sep-13	29-Sep-13	A	Arachnida, Araneae	1
81	22-Sep-13	29-Sep-13	A	Coleoptera	1
81	22-Sep-13	29-Sep-13	A	Hemiptera, Aphididae	1
81	22-Sep-13	29-Sep-13	A	Hymenoptera, Formicidae	1
81	22-Sep-13	29-Sep-13	A	Diptera	3
81	22-Sep-13	29-Sep-13	A	Hymenoptera, Parasitoid	3
81	22-Sep-13	29-Sep-13	B	Hymenoptera, Formicidae	1
81	22-Sep-13	29-Sep-13	B	Coleoptera	1
81	22-Sep-13	29-Sep-13	B	Hemiptera, Cicadellidae	1
81	22-Sep-13	29-Sep-13	B	Arachnida, Araneae	1
81	22-Sep-13	29-Sep-13	B	Diptera	2
81	22-Sep-13	29-Sep-13	B	Hymenoptera, Parasitoid	3
82	22-Sep-13	29-Sep-13	A	Arachnida, Araneae	1
82	22-Sep-13	29-Sep-13	A	Coleoptera	1
82	22-Sep-13	29-Sep-13	A	Hemiptera, Aphididae	1
82	22-Sep-13	29-Sep-13	A	Diptera	2

Card # (grid)	Placement Date	Collection Date	Side (A/B)	Insect	Rating
82	22-Sep-13	29-Sep-13	A	Hymenoptera, Parasitoid	3
82	22-Sep-13	29-Sep-13	B	Hemiptera, Cicadellidae	1
82	22-Sep-13	29-Sep-13	B	Coleoptera	1
82	22-Sep-13	29-Sep-13	B	Diptera	2
82	22-Sep-13	29-Sep-13	B	Hymenoptera, Parasitoid	3
83	22-Sep-13	29-Sep-13	A	Collembola	1
83	22-Sep-13	29-Sep-13	A	Coleoptera	1
83	22-Sep-13	29-Sep-13	A	Arachnida, Araneae	1
83	22-Sep-13	29-Sep-13	A	Diptera	1
83	22-Sep-13	29-Sep-13	A	Coleoptera	1
83	22-Sep-13	29-Sep-13	A	Hemiptera, Cicadellidae, Typhlocybinae	1
83	22-Sep-13	29-Sep-13	A	Hemiptera, Aphididae	2
83	22-Sep-13	29-Sep-13	A	Hymenoptera, Formicidae	2
83	22-Sep-13	29-Sep-13	A	Diptera	2
83	22-Sep-13	29-Sep-13	A	Hymenoptera, Parasitoid	2
83	22-Sep-13	29-Sep-13	A	Hymenoptera, Parasitoid	3
83	22-Sep-13	29-Sep-13	B	Hemiptera, Aphididae	1
83	22-Sep-13	29-Sep-13	B	Hymenoptera, Formicidae	1
83	22-Sep-13	29-Sep-13	B	Diptera	1
83	22-Sep-13	29-Sep-13	B	Hymenoptera, Parasitoid	1
83	22-Sep-13	29-Sep-13	B	Coleoptera	1
83	22-Sep-13	29-Sep-13	B	Coleoptera	1
83	22-Sep-13	29-Sep-13	B	Diptera	3
83	22-Sep-13	29-Sep-13	B	Hymenoptera, Parasitoid	3
84	22-Sep-13	29-Sep-13	A	Coleoptera	1
84	22-Sep-13	29-Sep-13	A	Hemiptera, Cicadellidae, Macrosteles	1
84	22-Sep-13	29-Sep-13	A	Arachnida, Araneae	1
84	22-Sep-13	29-Sep-13	A	Hemiptera, Aphididae	2

Card # (grid)	Placement Date	Collection Date	Side (A/B)	Insect	Rating
84	22-Sep-13	29-Sep-13	A	Hymenoptera, Parasitoid	3
84	22-Sep-13	29-Sep-13	A	Diptera	3
84	22-Sep-13	29-Sep-13	B	Arachnida, Araneae	1
84	22-Sep-13	29-Sep-13	B	Hemiptera, Cicadellidae, Typhlocybinae	1
84	22-Sep-13	29-Sep-13	B	Coleoptera	2
84	22-Sep-13	29-Sep-13	B	Diptera	2
84	22-Sep-13	29-Sep-13	B	Hymenoptera, Parasitoid	3
85	22-Sep-13	29-Sep-13	A	Arachnida, Araneae	1
85	22-Sep-13	29-Sep-13	A	Hemiptera, Aphididae	1
85	22-Sep-13	29-Sep-13	A	Coleoptera	1
85	22-Sep-13	29-Sep-13	A	Hemiptera, Cicadellidae, Typhlocybinae	1
85	22-Sep-13	29-Sep-13	A	Hymenoptera, Parasitoid	2
85	22-Sep-13	29-Sep-13	B	Coleoptera	1
85	22-Sep-13	29-Sep-13	B	Thrips (Order: Thysanoptera)	1
85	22-Sep-13	29-Sep-13	B	Hemiptera, Aphididae	1
85	22-Sep-13	29-Sep-13	B	Arachnida, Araneae	1
85	22-Sep-13	29-Sep-13	B	Diptera	3
85	22-Sep-13	29-Sep-13	B	Hymenoptera, Parasitoid	3
86	22-Sep-13	29-Sep-13	A	Hymenoptera, Formicidae	1
86	22-Sep-13	29-Sep-13	A	Coleoptera	1
86	22-Sep-13	29-Sep-13	A	Hemiptera, Aphididae	1
86	22-Sep-13	29-Sep-13	A	Hemiptera, Cicadellidae, Typhlocybinae	1
86	22-Sep-13	29-Sep-13	B	Coleoptera	1
86	22-Sep-13	29-Sep-13	B	Hemiptera, Aphididae	1
86	22-Sep-13	29-Sep-13	B	Arachnida, Araneae	1
86	22-Sep-13	29-Sep-13	B	Hymenoptera, Formicidae	2

Card # (grid)	Placement Date	Collection Date	Side (A/B)	Insect	Rating
86	22-Sep-13	29-Sep-13	B	Hymenoptera, Parasitoid	3
86	22-Sep-13	29-Sep-13	B	Diptera	3
90	22-Sep-13	29-Sep-13	A	lepidoptera	1
90	22-Sep-13	29-Sep-13	A	Hymenoptera, Parasitoid	1
90	22-Sep-13	29-Sep-13	A	Diptera	2
90	22-Sep-13	29-Sep-13	A	Coleoptera	2
90	22-Sep-13	29-Sep-13	A	Hemiptera, Aphididae	3
90	22-Sep-13	29-Sep-13	A	Hemiptera, Cicadellidae	3
90	22-Sep-13	29-Sep-13	B	Hemiptera, Aphididae	1
90	22-Sep-13	29-Sep-13	B	Coleoptera	1
90	22-Sep-13	29-Sep-13	B	Hemiptera, Cicadellidae	1
90	22-Sep-13	29-Sep-13	B	Diptera	1
90	22-Sep-13	29-Sep-13	B	Hymenoptera, Parasitoid	1
92	22-Sep-13	29-Sep-13	A	None observed	0
92	22-Sep-13	29-Sep-13	A	None observed	0
92	22-Sep-13	29-Sep-13	A	Hymenoptera, Parasitoid	1
92	22-Sep-13	29-Sep-13	A	Hymenoptera, Parasitoid	1
92	22-Sep-13	29-Sep-13	A	Isotomidae (Collembola)	1
92	22-Sep-13	29-Sep-13	A	Hemiptera, Cicadellidae, Typhlocybinae	1
92	22-Sep-13	29-Sep-13	A	Hymenoptera, Parasitoid	1
92	22-Sep-13	29-Sep-13	A	Hymenoptera, Parasitoid	1
92	22-Sep-13	29-Sep-13	A	Hymenoptera, Parasitoid	1
92	22-Sep-13	29-Sep-13	A	Hemiptera, Cicadellidae, Typhlocybinae	1
92	22-Sep-13	29-Sep-13	A	Diptera, Chironomidae, Chironomini	1
92	22-Sep-13	29-Sep-13	A	Hemiptera, Fulgoroidea	1
92	22-Sep-13	29-Sep-13	A	Hymenoptera, Parasitoid	1

Card # (grid)	Placement Date	Collection Date	Side (A/B)	Insect	Rating
92	22-Sep-13	29-Sep-13	A	Diptera, Psychodidae, Psychodinae	1
92	22-Sep-13	29-Sep-13	A	Hemiptera, Cicadellidae, Typhlocybinae	1
92	22-Sep-13	29-Sep-13	A	Diptera, Nematocera, Cecidomyiidae	1
92	22-Sep-13	29-Sep-13	A	Diptera, Nematocera, Cecidomyiidae	1
92	22-Sep-13	29-Sep-13	A	Hemiptera, Cicadellidae, Typhlocybinae	1
92	22-Sep-13	29-Sep-13	A	Unknown	1
92	22-Sep-13	29-Sep-13	A	Hemiptera, Cicadellidae, Typhlocybinae	1
92	22-Sep-13	29-Sep-13	A	Diptera, Psychodidae, Psychodinae	1
92	22-Sep-13	29-Sep-13	A	Diptera, Psychodidae, Psychodinae	1
92	22-Sep-13	29-Sep-13	A	Unknown	1
92	22-Sep-13	29-Sep-13	A	Hemiptera, Cicadellidae, Typhlocybinae	1
92	22-Sep-13	29-Sep-13	A	Hemiptera, Cicadellidae, Typhlocybinae	1
92	22-Sep-13	29-Sep-13	A	Diptera, Nematocera, Cecidomyiidae	1
92	22-Sep-13	29-Sep-13	A	Diptera, Psychodidae, Psychodinae	1
92	22-Sep-13	29-Sep-13	A	Diptera, Psychodidae, Psychodinae	1
92	22-Sep-13	29-Sep-13	A	Diptera, Nematocera, Cecidomyiidae	1
92	22-Sep-13	29-Sep-13	A	Hemiptera, Cicadellidae, Typhlocybinae	1
92	22-Sep-13	29-Sep-13	A	Hemiptera, Cicadellidae, Typhlocybinae	1

Card # (grid)	Placement Date	Collection Date	Side (A/B)	Insect	Rating
92	22-Sep-13	29-Sep-13	A	Diptera, Psychodidae, Psychodinae	1
92	22-Sep-13	29-Sep-13	A	Hemiptera, Cicadellidae, Typhlocybinae	1
92	22-Sep-13	29-Sep-13	A	Hymenoptera, formicoidea	1
92	22-Sep-13	29-Sep-13	A	Diptera, Nematocera,Cecidomyii dae	1
92	22-Sep-13	29-Sep-13	A	Hemiptera, Cicadellidae, Typhlocybinae	1
92	22-Sep-13	29-Sep-13	A	Hymenoptera, Parasitoid	1
92	22-Sep-13	29-Sep-13	A	Hymenoptera, Parasitoid	1
92	22-Sep-13	29-Sep-13	A	Diptera, Nematocera, Cecidomyiidae	1
92	22-Sep-13	29-Sep-13	A	Hymenoptera, Parasitoid	2
92	22-Sep-13	29-Sep-13	A	Hymenoptera, Parasitoid	2
92	22-Sep-13	29-Sep-13	B	Hymenoptera, Parasitoid	1
92	22-Sep-13	29-Sep-13	B	Hymenoptera, Parasitoid	1
92	22-Sep-13	29-Sep-13	B	Unknown	1
92	22-Sep-13	29-Sep-13	B	Hymenoptera, Parasitoid	1
92	22-Sep-13	29-Sep-13	B	Diptera, Nematocera, Cecidomyiidae	1
92	22-Sep-13	29-Sep-13	B	Diptera, unknown	1
92	22-Sep-13	29-Sep-13	B	Diptera, Nematocera, Cecidomyiidae	1
92	22-Sep-13	29-Sep-13	B	Diptera, unknown	1
92	22-Sep-13	29-Sep-13	B	Hymenoptera, Parasitoid	1
92	22-Sep-13	29-Sep-13	B	Hymenoptera, Parasitoid	1

Card # (grid)	Placement Date	Collection Date	Side (A/B)	Insect	Rating
92	22-Sep-13	29-Sep-13	B	Hemiptera, Cicadellidae, Typhlocybinae	1
92	22-Sep-13	29-Sep-13	B	Hymenoptera, Parasitoid	1
92	22-Sep-13	29-Sep-13	B	Hymenoptera, Parasitoid	1
92	22-Sep-13	29-Sep-13	B	Diptera, Nematocera, Cecidomyiidae	1
92	22-Sep-13	29-Sep-13	B	Hemiptera, Fulgoroidea	1
92	22-Sep-13	29-Sep-13	B	Diptera, unknown	1
92	22-Sep-13	29-Sep-13	B	Diptera, unknown	1
92	22-Sep-13	29-Sep-13	B	Hymenoptera, Parasitoid	1
92	22-Sep-13	29-Sep-13	B	Diptera, Nematocera, Cecidomyiidae	1
92	22-Sep-13	29-Sep-13	B	Hymenoptera, Formicidae	1
92	22-Sep-13	29-Sep-13	B	Hymenoptera, Parasitoid	1
92	22-Sep-13	29-Sep-13	B	Hemiptera, Cicadellidae, Typhlocybinae	1
92	22-Sep-13	29-Sep-13	B	Hemiptera, unknown	1
92	22-Sep-13	29-Sep-13	B	Hymenoptera, Parasitoid	1
92	22-Sep-13	29-Sep-13	B	Hymenoptera, Parasitoid	1
92	22-Sep-13	29-Sep-13	B	Diptera, Simuliidae	1
92	22-Sep-13	29-Sep-13	B	Hymenoptera, Parasitoid	1
92	22-Sep-13	29-Sep-13	B	Hemiptera, Cicadellidae, Macrosteles	1
92	22-Sep-13	29-Sep-13	B	Hymenoptera, Parasitoid	1
92	22-Sep-13	29-Sep-13	B	Arachnida, Araneae	1
92	22-Sep-13	29-Sep-13	B	Hemiptera, Cicadellidae, Typhlocybinae	1
92	22-Sep-13	29-Sep-13	B	Hymenoptera, Parasitoid	1

Card # (grid)	Placement Date	Collection Date	Side (A/B)	Insect	Rating
92	22-Sep-13	29-Sep-13	B	Diptera, Simuliidae	1
92	22-Sep-13	29-Sep-13	B	Hymenoptera, Parasitoid	1
92	22-Sep-13	29-Sep-13	B	Hymenoptera, Parasitoid	1
92	22-Sep-13	29-Sep-13	B	Hymenoptera, Parasitoid	1
92	22-Sep-13	29-Sep-13	B	Hymenoptera, Parasitoid	1
92	22-Sep-13	29-Sep-13	B	Hemiptera, Cicadellidae, Typhlocybinae	1
92	22-Sep-13	29-Sep-13	B	Hemiptera, Cicadellidae, Typhlocybinae	1
92	22-Sep-13	29-Sep-13	B	Diptera, Simuliidae	1
92	22-Sep-13	29-Sep-13	B	Hymenoptera, Parasitoid	1
93	22-Sep-13	29-Sep-13	A	Arachnida, Araneae	1
93	22-Sep-13	29-Sep-13	A	Coleoptera	1
93	22-Sep-13	29-Sep-13	A	Hemiptera, Cicadellidae	1
93	22-Sep-13	29-Sep-13	A	Hymenoptera, Parasitoid	2
93	22-Sep-13	29-Sep-13	A	Diptera	2
93	22-Sep-13	29-Sep-13	A	Hemiptera, Aphididae	2
93	22-Sep-13	29-Sep-13	B	Coleoptera	1
93	22-Sep-13	29-Sep-13	B	Hymenoptera, Parasitoid	1
93	22-Sep-13	29-Sep-13	B	Hemiptera, Cicadellidae	1
93	22-Sep-13	29-Sep-13	B	Gastropoda (snail)	1
93	22-Sep-13	29-Sep-13	B	Diptera	1
94	22-Sep-13	29-Sep-13	A	Hemiptera, Aphididae	1
94	22-Sep-13	29-Sep-13	A	Diptera	2
94	22-Sep-13	29-Sep-13	A	Hymenoptera, Parasitoid	2
94	22-Sep-13	29-Sep-13	A	Hemiptera, Cicadellidae, Typhlocybinae	2
94	22-Sep-13	29-Sep-13	B	Hemiptera, Aphididae	1
94	22-Sep-13	29-Sep-13	B	Arachnida, Araneae	1
94	22-Sep-13	29-Sep-13	B	Diptera	2

Card # (grid)	Placement Date	Collection Date	Side (A/B)	Insect	Rating
94	22-Sep-13	29-Sep-13	B	Hymenoptera, Formicidae	2
94	22-Sep-13	29-Sep-13	B	Hymenoptera, Parasitoid	3
94	22-Sep-13	29-Sep-13	B	Hemiptera, Cicadellidae, Typhlocybinae	3
95	22-Sep-13	29-Sep-13	A	Arachnida, Araneae	1
95	22-Sep-13	29-Sep-13	A	Hymenoptera, Parasitoid	1
95	22-Sep-13	29-Sep-13	A	Hymenoptera, Parasitoid	2
95	22-Sep-13	29-Sep-13	A	Diptera	2
95	22-Sep-13	29-Sep-13	B	Diptera	1
95	22-Sep-13	29-Sep-13	B	Hemiptera, unknown	1
95	22-Sep-13	29-Sep-13	B	Thrips (Order: Thysanoptera)	1
95	22-Sep-13	29-Sep-13	B	Hemiptera, Cicadellidae	1
95	22-Sep-13	29-Sep-13	B	Coleoptera	1
95	22-Sep-13	29-Sep-13	B	Hymenoptera, Parasitoid	2
95	22-Sep-13	29-Sep-13	B	Hemiptera, Aphididae	2
96	22-Sep-13	29-Sep-13	A	Hemiptera, Cicadellidae, Macrosteles	1
96	22-Sep-13	29-Sep-13	A	Coleoptera	1
96	22-Sep-13	29-Sep-13	A	Diptera	2
96	22-Sep-13	29-Sep-13	A	Hymenoptera, Formicidae	2
96	22-Sep-13	29-Sep-13	A	Hymenoptera, Parasitoid	2
96	22-Sep-13	29-Sep-13	B	Coleoptera	1
96	22-Sep-13	29-Sep-13	B	Diptera	1
96	22-Sep-13	29-Sep-13	B	Hymenoptera, Formicidae	2
96	22-Sep-13	29-Sep-13	B	Hymenoptera, Parasitoid	2
97	22-Sep-13	29-Sep-13	A	Hemiptera, Aphididae	1
97	22-Sep-13	29-Sep-13	A	Arachnida, Araneae	1

Card # (grid)	Placement Date	Collection Date	Side (A/B)	Insect	Rating
97	22-Sep-13	29-Sep-13	A	Hemiptera, Cicadellidae, Typhlocybinae	1
97	22-Sep-13	29-Sep-13	A	Diptera	2
97	22-Sep-13	29-Sep-13	A	Hymenoptera, Parasitoid	2
97	22-Sep-13	29-Sep-13	B	Acari	1
97	22-Sep-13	29-Sep-13	B	Coleoptera (ladybeetle)	1
97	22-Sep-13	29-Sep-13	B	Slug (Class: Gastropoda)	1
97	22-Sep-13	29-Sep-13	B	Hemiptera, Cicadellidae, Typhlocybinae	1
97	22-Sep-13	29-Sep-13	B	Arachnida, Araneae	1
97	22-Sep-13	29-Sep-13	B	Hymenoptera, Parasitoid	2
97	22-Sep-13	29-Sep-13	B	Diptera	2
98	22-Sep-13	29-Sep-13	A	None observed	0
98	22-Sep-13	29-Sep-13	A	Hemiptera, Cicadellidae, Typhlocybinae	1
98	22-Sep-13	29-Sep-13	A	Diptera, unknown	1
98	22-Sep-13	29-Sep-13	A	Hemiptera, Cicadellidae, Typhlocybinae	1
98	22-Sep-13	29-Sep-13	A	Coleoptera (1)	1
98	22-Sep-13	29-Sep-13	A	Hymenoptera, Parasitoid	1
98	22-Sep-13	29-Sep-13	A	Chironomidae	1
98	22-Sep-13	29-Sep-13	A	Hemiptera, Aphididae	1
98	22-Sep-13	29-Sep-13	A	Neuroptera	1
98	22-Sep-13	29-Sep-13	A	Hemiptera, Aphididae	1
98	22-Sep-13	29-Sep-13	A	Hemiptera, Cicadellidae, Typhlocybinae	1
98	22-Sep-13	29-Sep-13	A	Hemiptera, Cicadellidae, Macrosteles	1
98	22-Sep-13	29-Sep-13	A	Chironomidae	1
98	22-Sep-13	29-Sep-13	A	Unknown	1

Card # (grid)	Placement Date	Collection Date	Side (A/B)	Insect	Rating
98	22-Sep-13	29-Sep-13	A	Hemiptera, Cicadellidae, Macrosteles	1
98	22-Sep-13	29-Sep-13	A	Ceratopogonidae	1
98	22-Sep-13	29-Sep-13	A	Hemiptera, Cicadellidae, Macrosteles	1
98	22-Sep-13	29-Sep-13	A	Diptera, unknown (1)	1
98	22-Sep-13	29-Sep-13	A	Diptera, unknown (1)	1
98	22-Sep-13	29-Sep-13	A	Ceratopogonidae	1
98	22-Sep-13	29-Sep-13	A	Hemiptera, Cicadellidae, Macrosteles	1
98	22-Sep-13	29-Sep-13	A	Unknown (2)	1
98	22-Sep-13	29-Sep-13	A	Hemiptera, Cicadellidae, Macrosteles	1
98	22-Sep-13	29-Sep-13	A	Hemiptera, Cicadellidae, Typhlocybinae	1
98	22-Sep-13	29-Sep-13	A	Diptera, unknown (1)	1
98	22-Sep-13	29-Sep-13	A	Ceratopogonidae	1
98	22-Sep-13	29-Sep-13	A	Hemiptera, Cicadellidae, Typhlocybinae	1
98	22-Sep-13	29-Sep-13	A	Hemiptera, Cicadellidae, Macrosteles	1
98	22-Sep-13	29-Sep-13	A	Hemiptera, Cicadellidae, Typhlocybinae	1
98	22-Sep-13	29-Sep-13	A	Hymenoptera, Parasitoid	1
98	22-Sep-13	29-Sep-13	A	Hemiptera, Cicadellidae, Macrosteles	1
98	22-Sep-13	29-Sep-13	A	Ceratopogonidae	1
98	22-Sep-13	29-Sep-13	A	Hemiptera, Cicadellidae, Typhlocybinae	1
98	22-Sep-13	29-Sep-13	A	Diptera, unknown (1)	1

Card # (grid)	Placement Date	Collection Date	Side (A/B)	Insect	Rating
98	22-Sep-13	29-Sep-13	A	Hemiptera, Cicadellidae, Typhlocybinæ	1
98	22-Sep-13	29-Sep-13	A	Hemiptera, Cicadellidae, Macrosteles	1
98	22-Sep-13	29-Sep-13	A	Hemiptera, Cicadellidae, Typhlocybinæ	1
98	22-Sep-13	29-Sep-13	A	Diptera, unknown (1)	1
98	22-Sep-13	29-Sep-13	A	Hymenoptera, Parasitoid	1
98	22-Sep-13	29-Sep-13	A	Hemiptera, Cicadellidae, Macrosteles	1
98	22-Sep-13	29-Sep-13	A	Hemiptera, Cicadellidae, Macrosteles	1
98	22-Sep-13	29-Sep-13	A	Hemiptera, Cicadellidae, Typhlocybinæ	1
98	22-Sep-13	29-Sep-13	A	Hemiptera, Cicadellidae, Typhlocybinæ	1
98	22-Sep-13	29-Sep-13	A	Hemiptera, Cicadellidae, Macrosteles	1
98	22-Sep-13	29-Sep-13	A	Diptera, unknown (1)	1
98	22-Sep-13	29-Sep-13	A	Hemiptera, Cicadellidae, Typhlocybinæ	1
98	22-Sep-13	29-Sep-13	A	Coleoptera	1
98	22-Sep-13	29-Sep-13	B	None observed	0
98	22-Sep-13	29-Sep-13	B	None observed	0
98	22-Sep-13	29-Sep-13	B	None observed	0
98	22-Sep-13	29-Sep-13	B	None observed	0
98	22-Sep-13	29-Sep-13	B	Hemiptera, Aphididae	1
98	22-Sep-13	29-Sep-13	B	Hemiptera, Cicadellidae, Typhlocybinæ	1
98	22-Sep-13	29-Sep-13	B	Diptera, Culicidae	1

Card # (grid)	Placement Date	Collection Date	Side (A/B)	Insect	Rating
98	22-Sep-13	29-Sep-13	B	Hymenoptera, Parasitoid	1
98	22-Sep-13	29-Sep-13	B	Hemiptera, Cicadellidae, Macrosteles	1
98	22-Sep-13	29-Sep-13	B	Hymenoptera, Parasitoid	1
98	22-Sep-13	29-Sep-13	B	Hemiptera, Aphididae	1
98	22-Sep-13	29-Sep-13	B	Hemiptera, Cicadellidae, Macrosteles	1
98	22-Sep-13	29-Sep-13	B	Hymenoptera, Parasitoid	1
98	22-Sep-13	29-Sep-13	B	Hemiptera, Cicadellidae, Typhlocybinae	1
98	22-Sep-13	29-Sep-13	B	Hymenoptera, Parasitoid	1
98	22-Sep-13	29-Sep-13	B	Hemiptera, Cicadellidae, Typhlocybinae	1
98	22-Sep-13	29-Sep-13	B	Hemiptera, Aphididae	1
98	22-Sep-13	29-Sep-13	B	Hemiptera, Cicadellidae, Macrosteles	1
98	22-Sep-13	29-Sep-13	B	Hemiptera, Cicadellidae, Typhlocybinae	1
98	22-Sep-13	29-Sep-13	B	Hemiptera, Aphididae	1
98	22-Sep-13	29-Sep-13	B	Diptera, Simuliidae	1
98	22-Sep-13	29-Sep-13	B	Hemiptera, Cicadellidae, Macrosteles	1
98	22-Sep-13	29-Sep-13	B	Hemiptera, Cicadellidae, Typhlocybinae	1
98	22-Sep-13	29-Sep-13	B	Hymenoptera, Parasitoid	1
98	22-Sep-13	29-Sep-13	B	Hemiptera, Cicadellidae, Typhlocybinae	1
98	22-Sep-13	29-Sep-13	B	Coleoptera, unknown (ladybeetle-type)	1

Card # (grid)	Placement Date	Collection Date	Side (A/B)	Insect	Rating
98	22-Sep-13	29-Sep-13	B	Coleoptera, unknown (dark, glossy)	1
98	22-Sep-13	29-Sep-13	B	Diptera, unknown (1)	1
98	22-Sep-13	29-Sep-13	B	Hemiptera, Cicadellidae, Typhlocybinae	1
98	22-Sep-13	29-Sep-13	B	Hymenoptera, Parasitoid	1
98	22-Sep-13	29-Sep-13	B	Diptera, unknown	1
98	22-Sep-13	29-Sep-13	B	Hemiptera, Aphididae	1
98	22-Sep-13	29-Sep-13	B	Arachnida, Araneae	1
98	22-Sep-13	29-Sep-13	B	Hemiptera, Cicadellidae, Typhlocybinae	1
98	22-Sep-13	29-Sep-13	B	Hemiptera, Aphididae	1
98	22-Sep-13	29-Sep-13	B	Hymenoptera, Parasitoid	1
98	22-Sep-13	29-Sep-13	B	Coleoptera, unknown (ladybeetle-type)	1
98	22-Sep-13	29-Sep-13	B	Hemiptera, Cicadellidae, Typhlocybinae	1
98	22-Sep-13	29-Sep-13	B	Diptera, unknown	1
98	22-Sep-13	29-Sep-13	B	Hemiptera, Aphididae	1
98	22-Sep-13	29-Sep-13	B	Hymenoptera, Parasitoid	1
98	22-Sep-13	29-Sep-13	B	Coleoptera, unknown (ladybeetle-type)	1
98	22-Sep-13	29-Sep-13	B	Hemiptera, Cicadellidae, Macrosteles	1
98	22-Sep-13	29-Sep-13	B	None observed	0
99	22-Sep-13	29-Sep-13	A	Hymenoptera, Parasitoid	1
99	22-Sep-13	29-Sep-13	B	Hymenoptera, Parasitoid	1
99	22-Sep-13	29-Sep-13	B	Hemiptera, Aphididae	1
100	22-Sep-13	29-Sep-13	A	Coleoptera	1
100	22-Sep-13	29-Sep-13	A	Hymenoptera, Parasitoid	2
100	22-Sep-13	29-Sep-13	A	Hemiptera, Aphididae	2

Card # (grid)	Placement Date	Collection Date	Side (A/B)	Insect	Rating
100	22-Sep-13	29-Sep-13	A	Hemiptera, Cicadellidae	2
100	22-Sep-13	29-Sep-13	B	Collembola	1
100	22-Sep-13	29-Sep-13	B	Arachnida, Araneae	1
100	22-Sep-13	29-Sep-13	B	Slug (Class: Gastropoda)	1
100	22-Sep-13	29-Sep-13	B	Hemiptera, Aphididae	2
100	22-Sep-13	29-Sep-13	B	Hymenoptera, Parasitoid	2
100	22-Sep-13	29-Sep-13	B	Diptera	2
100	22-Sep-13	29-Sep-13	B	Hemiptera, Cicadellidae	3
1a	29-Sep-13	10-Oct-13	A	Arachnida, Araneae	1
1a	29-Sep-13	10-Oct-13	A	Coleoptera	1
1a	29-Sep-13	10-Oct-13	A	Hemiptera, Cicadellidae	1
1a	29-Sep-13	10-Oct-13	A	Lepidoptera	1
1a	29-Sep-13	10-Oct-13	A	Hymenoptera, Parasitoid	2
1a	29-Sep-13	10-Oct-13	A	Diptera	3
1a	29-Sep-13	10-Oct-13	B	Hymenoptera, Parasitoid	1
1a	29-Sep-13	10-Oct-13	B	Arachnida, Araneae	1
1a	29-Sep-13	10-Oct-13	B	Coleoptera	1
1a	29-Sep-13	10-Oct-13	B	Hemiptera, Cicadellidae	1
1a	29-Sep-13	10-Oct-13	B	Hymenoptera, Formicidae	1
1a	29-Sep-13	10-Oct-13	B	Diptera	3
2a	29-Sep-13	10-Oct-13	A	Hymenoptera, Parasitoid	1
2a	29-Sep-13	10-Oct-13	A	Arachnida, Araneae	1
2a	29-Sep-13	10-Oct-13	A	Hemiptera, Cicadellidae	1
2a	29-Sep-13	10-Oct-13	B	Coleoptera	1
2a	29-Sep-13	10-Oct-13	B	Arachnida, Araneae	1
2a	29-Sep-13	10-Oct-13	B	Hemiptera, Aphididae	1
2a	29-Sep-13	10-Oct-13	B	Hymenoptera, Formicidae	1
2a	29-Sep-13	10-Oct-13	B	Diptera	2
2a	29-Sep-13	10-Oct-13	B	Hemiptera, Cicadellidae	2
3a	29-Sep-13	10-Oct-13	A	Arachnida, Araneae	1
3a	29-Sep-13	10-Oct-13	A	Coleoptera	1

Card # (grid)	Placement Date	Collection Date	Side (A/B)	Insect	Rating
3a	29-Sep-13	10-Oct-13	A	Hymenoptera, Parasitoid	1
3a	29-Sep-13	10-Oct-13	A	Hymenoptera, Formicidae	1
3a	29-Sep-13	10-Oct-13	A	Diptera	1
3a	29-Sep-13	10-Oct-13	B	Hymenoptera, Parasitoid	1
3a	29-Sep-13	10-Oct-13	B	Hemiptera, Aphididae	1
3a	29-Sep-13	10-Oct-13	B	Arachnida, Araneae	1
3a	29-Sep-13	10-Oct-13	B	Odonata	1
3a	29-Sep-13	10-Oct-13	B	Diptera	2
3a	29-Sep-13	10-Oct-13	B	Hemiptera, Cicadellidae	2
4a	29-Sep-13	10-Oct-13	A	Arachnida, Araneae	1
4a	29-Sep-13	10-Oct-13	A	Hymenoptera, Formicidae	1
4a	29-Sep-13	10-Oct-13	A	Hemiptera, Aphididae	1
4a	29-Sep-13	10-Oct-13	A	Hemiptera, Cicadellidae	1
4a	29-Sep-13	10-Oct-13	A	Collembola	1
4a	29-Sep-13	10-Oct-13	A	Coleoptera	2
4a	29-Sep-13	10-Oct-13	A	Diptera	2
4a	29-Sep-13	10-Oct-13	A	Hymenoptera, Parasitoid	2
4a	29-Sep-13	10-Oct-13	B	Hemiptera, Cicadellidae	1
4a	29-Sep-13	10-Oct-13	B	Hymenoptera, Parasitoid	1
4a	29-Sep-13	10-Oct-13	B	Diptera	1
4a	29-Sep-13	10-Oct-13	B	Coleoptera	1
4a	29-Sep-13	10-Oct-13	B	Arachnida, Araneae	1
4a	29-Sep-13	10-Oct-13	B	Hymenoptera, Formicidae	1
5a	29-Sep-13	10-Oct-13	A	Diptera	1
5a	29-Sep-13	10-Oct-13	A	Hemiptera, Cicadellidae	1
5a	29-Sep-13	10-Oct-13	A	Collembola	1
5a	29-Sep-13	10-Oct-13	A	Coleoptera	2
5a	29-Sep-13	10-Oct-13	A	Arachnida, Araneae	2
5a	29-Sep-13	10-Oct-13	A	Hymenoptera, Parasitoid	3
5a	29-Sep-13	10-Oct-13	B	Coleoptera	1
5a	29-Sep-13	10-Oct-13	B	Arachnida, Araneae	1

Card # (grid)	Placement Date	Collection Date	Side (A/B)	Insect	Rating
5a	29-Sep-13	10-Oct-13	B	Hymenoptera, Parasitoid	1
5a	29-Sep-13	10-Oct-13	B	Diptera	1
7a	29-Sep-13	10-Oct-13	A	Hemiptera, Aphididae	1
7a	29-Sep-13	10-Oct-13	A	Coleoptera	1
7a	29-Sep-13	10-Oct-13	A	Hymenoptera, Vespidae	1
7a	29-Sep-13	10-Oct-13	A	Thrips (Order: Thysanoptera)	1
7a	29-Sep-13	10-Oct-13	A	Hemiptera, Cicadellidae	2
7a	29-Sep-13	10-Oct-13	A	Diptera	3
7a	29-Sep-13	10-Oct-13	A	Hymenoptera, Parasitoid	3
7a	29-Sep-13	10-Oct-13	B	Orthoptera	1
7a	29-Sep-13	10-Oct-13	B	Coleoptera	1
7a	29-Sep-13	10-Oct-13	B	Hymenoptera, Ichneumonidae	1
7a	29-Sep-13	10-Oct-13	B	Thrips (Order: Thysanoptera)	1
7a	29-Sep-13	10-Oct-13	B	Arachnida, Araneae	1
7a	29-Sep-13	10-Oct-13	B	Hymenoptera, Formicidae	1
7a	29-Sep-13	10-Oct-13	B	Hemiptera, Cicadellidae	2
7a	29-Sep-13	10-Oct-13	B	Hymenoptera, Parasitoid	3
7a	29-Sep-13	10-Oct-13	B	Diptera	3
8a	29-Sep-13	10-Oct-13	A	Hymenoptera, Formicidae	1
8a	29-Sep-13	10-Oct-13	A	Orthoptera	1
8a	29-Sep-13	10-Oct-13	A	Odonata	1
8a	29-Sep-13	10-Oct-13	A	Arachnida, Araneae	2
8a	29-Sep-13	10-Oct-13	A	Coleoptera	2
8a	29-Sep-13	10-Oct-13	B	Hymenoptera, Parasitoid	1
8a	29-Sep-13	10-Oct-13	B	Thrips (Order: Thysanoptera)	1
8a	29-Sep-13	10-Oct-13	B	Diptera	1
8a	29-Sep-13	10-Oct-13	B	Arachnida, Araneae	1
9a	29-Sep-13	10-Oct-13	A	Coleoptera	1

Card # (grid)	Placement Date	Collection Date	Side (A/B)	Insect	Rating
9a	29-Sep-13	10-Oct-13	A	Hymenoptera, Formicidae	1
9a	29-Sep-13	10-Oct-13	A	Arachnida, Araneae	2
9a	29-Sep-13	10-Oct-13	A	Hemiptera, Aphididae	2
9a	29-Sep-13	10-Oct-13	A	Hemiptera, Cicadellidae	2
9a	29-Sep-13	10-Oct-13	A	Coccinellidae	3
9a	29-Sep-13	10-Oct-13	A	Hymenoptera, Parasitoid	3
9a	29-Sep-13	10-Oct-13	A	Diptera	3
9a	29-Sep-13	10-Oct-13	B	Coleoptera	1
9a	29-Sep-13	10-Oct-13	B	Hymenoptera, Parasitoid	1
9a	29-Sep-13	10-Oct-13	B	Hemiptera, Aphididae	1
9a	29-Sep-13	10-Oct-13	B	Arachnida, Araneae	2
10a	29-Sep-13	10-Oct-13	A	Hemiptera, Aphididae	1
10a	29-Sep-13	10-Oct-13	A	Hemiptera, Cicadellidae	1
10a	29-Sep-13	10-Oct-13	A	Hymenoptera, Formicidae	1
10a	29-Sep-13	10-Oct-13	A	Orthoptera	1
10a	29-Sep-13	10-Oct-13	A	Coleoptera	2
10a	29-Sep-13	10-Oct-13	A	Diptera	2
10a	29-Sep-13	10-Oct-13	A	Arachnida, Araneae	2
10a	29-Sep-13	10-Oct-13	A	Hymenoptera, Parasitoid	3
10a	29-Sep-13	10-Oct-13	B	Hymenoptera, Formicidae	1
10a	29-Sep-13	10-Oct-13	B	Arachnida, Araneae	1
10a	29-Sep-13	10-Oct-13	B	Hymenoptera, Parasitoid	1
10a	29-Sep-13	10-Oct-13	B	Coleoptera	1
10a	29-Sep-13	10-Oct-13	B	Hemiptera, Cicadellidae	1
10a	29-Sep-13	10-Oct-13	B	Orthoptera	1
11a	29-Sep-13	10-Oct-13	A	Lepidoptera	1
11a	29-Sep-13	10-Oct-13	A	Hymenoptera, Formicidae	1
11a	29-Sep-13	10-Oct-13	A	Arachnida, Araneae	2
11a	29-Sep-13	10-Oct-13	A	Hemiptera, Cicadellidae	2
11a	29-Sep-13	10-Oct-13	A	Diptera	3

Card # (grid)	Placement Date	Collection Date	Side (A/B)	Insect	Rating
11a	29-Sep-13	10-Oct-13	A	Hymenoptera, Parasitoid	3
11a	29-Sep-13	10-Oct-13	B	Hemiptera, Cicadellidae	1
11a	29-Sep-13	10-Oct-13	B	Thrips (Order: Thysanoptera)	1
11a	29-Sep-13	10-Oct-13	B	Diptera	2
11a	29-Sep-13	10-Oct-13	B	Arachnida, Araneae	2
11a	29-Sep-13	10-Oct-13	B	Coleoptera	2
11a	29-Sep-13	10-Oct-13	B	Hymenoptera, Parasitoid	2
12a	29-Sep-13	10-Oct-13	A	Coleoptera	1
12a	29-Sep-13	10-Oct-13	A	Hymenoptera, Parasitoid	2
12a	29-Sep-13	10-Oct-13	A	Arachnida, Araneae	3
12a	29-Sep-13	10-Oct-13	A	Diptera	3
12a	29-Sep-13	10-Oct-13	B	Diptera	1
12a	29-Sep-13	10-Oct-13	B	Coleoptera	1
12a	29-Sep-13	10-Oct-13	B	Hemiptera, Cicadellidae	1
12a	29-Sep-13	10-Oct-13	B	Arachnida, Araneae	1
12a	29-Sep-13	10-Oct-13	B	Hymenoptera, Formicidae	1
12a	29-Sep-13	10-Oct-13	B	Hemiptera, unknown	1
12a	29-Sep-13	10-Oct-13	B	Collembola	1
12a	29-Sep-13	10-Oct-13	B	Hymenoptera, Parasitoid	2
13a	29-Sep-13	10-Oct-13	A	Hemiptera, Cicadellidae	1
13a	29-Sep-13	10-Oct-13	A	Lepidoptera	1
13a	29-Sep-13	10-Oct-13	A	Arachnida, Araneae	1
13a	29-Sep-13	10-Oct-13	A	Diptera	3
13a	29-Sep-13	10-Oct-13	A	Hymenoptera, Parasitoid	3
13a	29-Sep-13	10-Oct-13	A	Coleoptera	3
13a	29-Sep-13	10-Oct-13	B	Hemiptera, Cicadellidae	1
13a	29-Sep-13	10-Oct-13	B	Hemiptera, Aphididae	1
13a	29-Sep-13	10-Oct-13	B	Diptera	2
13a	29-Sep-13	10-Oct-13	B	Hymenoptera, Parasitoid	2
13a	29-Sep-13	10-Oct-13	B	Coleoptera	2
14a	29-Sep-13	10-Oct-13	A	Odonata	1
14a	29-Sep-13	10-Oct-13	A	Hemiptera, Cicadellidae	1

Card # (grid)	Placement Date	Collection Date	Side (A/B)	Insect	Rating
14a	29-Sep-13	10-Oct-13	A	Orthoptera	1
14a	29-Sep-13	10-Oct-13	A	Coleoptera	2
14a	29-Sep-13	10-Oct-13	A	Diptera	2
14a	29-Sep-13	10-Oct-13	A	Arachnida, Araneae	2
14a	29-Sep-13	10-Oct-13	A	Hymenoptera, Parasitoid	2
14a	29-Sep-13	10-Oct-13	B	Hemiptera, Cicadellidae	1
14a	29-Sep-13	10-Oct-13	B	Diptera	1
14a	29-Sep-13	10-Oct-13	B	Hymenoptera, Parasitoid	2
14a	29-Sep-13	10-Oct-13	B	Arachnida, Araneae	2
14a	29-Sep-13	10-Oct-13	B	Coleoptera	3
15a	29-Sep-13	10-Oct-13	A	Coleoptera	1
15a	29-Sep-13	10-Oct-13	A	Hemiptera, Cicadellidae	1
15a	29-Sep-13	10-Oct-13	A	Odonata	1
15a	29-Sep-13	10-Oct-13	A	Hymenoptera, Parasitoid	2
15a	29-Sep-13	10-Oct-13	A	Diptera	2
15a	29-Sep-13	10-Oct-13	A	Hymenoptera, Vespidae	3
15a	29-Sep-13	10-Oct-13	B	Odonata	1
15a	29-Sep-13	10-Oct-13	B	Lepidoptera	1
15a	29-Sep-13	10-Oct-13	B	Arachnida, Araneae	1
15a	29-Sep-13	10-Oct-13	B	Coleoptera	1
15a	29-Sep-13	10-Oct-13	B	Hymenoptera, Vespidae	3
15a	29-Sep-13	10-Oct-13	B	Diptera	3

Rating Categories:

- 0: no insects observed on card
- 1: 1 to 5 individuals
- 2: 6 to 10 individuals
- 3: > 10 individuals